

TEST REPORT

Applicant/Manufacturer: Shenzhen Youmi Intelligent Technology Co., Ltd.
Address : 406-407 JinqiZhigu Building, 4/F, 1 Tangling Road, Nanshan District, Shenzhen City, China
Report Number: SZ1230324-14503E-SAA

Test Standard (s)

EN 50360:2017; EN 50566:2017; EN 50663:2017; EN 62479:2010

BS EN 50360:2017; BS EN 50566:2017; BS EN 50663:2017; BS EN 62479:2010

Sample Description

Product Type: Smart phone
Model No.: G3 Mecha
Multiple Model(s) No.: G5 Mecha
(model difference see product declaration of similarity)
Trade Mark: UMIDIGI
Date Received: 2023/03/27
Report Date: 2023/04/25

Test Result:	Pass*
--------------	-------

* In the configuration tested, the EUT complied with the standards above.

Prepared and Checked By:

Luke Jiang

Luke Jiang
SAR Engineer

Approved By:

Alvin Huang
Lab Manager

Note: BACL is not responsible for the authenticity of any test data provided by the applicant. Data included from the applicant that may affect test results are marked with an asterisk (*). Customer model name, addresses, names, trademarks etc. are not considered data.

This report cannot be reproduced except in full, without prior written approval of the Company. Unless otherwise stated the results shown in this test report refer only to the sample(s) tested. This report is valid only with a valid digital signature. The digital signature may be available only under the Adobe software above version 7.0.

Bay Area Compliance Laboratories Corp. (Shenzhen)

5F(B-West) , 6F, 7F, the 3rd Phase of Wan Li Industrial Building D, Shihua Rd, FuTian Free Trade Zone, Shenzhen, China
Tel: +86-755-33320018 Fax: +86-755-33320008 www.baclcorp.com.cn

Attestation of Test Results		
EUT Information	Company Name	Shenzhen Youmi Intelligent Technology Co., Ltd.
	EUT Description	Smart phone
	ModelNumber	G3 Mecha
	Multiple Model(s) :	G5 Mecha
	Serial Number	23N2_1
	Test Date	2023/04/08~2023/04/19
Frequency Band	Max. SAR Level(s) Measured	Limit(W/Kg)
EGSM 900	0.02 W/kg 10g Head SAR 0.09 W/kg 10g Body SAR	2.0
DCS 1800	0.47 W/kg 10g Head SAR 0.35 W/kg 10g Body SAR	
WCDMA Band 1	0.79 W/kg 10g Head SAR 0.66 W/kg 10g Body SAR	
WCDMA Band 8	0.02 W/kg 10g Head SAR 0.07 W/kg 10g Body SAR	
LTE Band 1	1.08 W/kg 10g Head SAR 0.74 W/kg 10g Body SAR	
LTE Band 3	1.02 W/kg 10g Head SAR 0.71 W/kg 10g Body SAR	
LTE Band 8	0.01 W/kg 10g Head SAR 0.07 W/kg 10g Body SAR	
LTE Band 28	0.08 W/kg 10g Head SAR 0.23 W/kg 10g Body SAR	
LTE Band 40	0.07 W/kg 10g Head SAR 0.20 W/kg 10g Body SAR	
WLAN 2.4G	0.75 W/kg 10g Head SAR 0.43 W/kg 10g Body SAR	
WLAN 5G	0.28 W/kg 10g Head SAR 0.21 W/kg 10g Body SAR	
Simultaneous(tx)	1.83 W/kg 10g Head SAR 1.17 W/kg 10g Body SAR	

Frequency Band	Max. SAR Level(s) Measured	Limit(W/Kg)
EGSM 900	0.69 W/kg 10g Limb SAR	4.0
DCS 1800	1.14 W/kg 10g Limb SAR	
WCDMA Band 1	1.94 W/kg 10g Limb SAR	
WCDMA Band 8	0.43 W/kg 10g Limb SAR	
LTE Band 1	2.33 W/kg 10g Limb SAR	
LTE Band 3	2.56 W/kg 10g Limb SAR	
LTE Band 8	0.47 W/kg 10g Limb SAR	
LTE Band 28	1.03 W/kg 10g Limb SAR	
LTE Band 40	1.59 W/kg 10g Limb SAR	
WLAN 2.4G	1.23 W/kg 10g Limb SAR	
WLAN 5G	0.29 W/kg 10g Limb SAR	
Simultaneous(tx)	3.79 W/kg 10g Limb SAR	

Applicable Standards	<p>EN50360: 2017;BS EN50360: 2017 Product standard to demonstrate the compliance of wireless communication devices, with the basic restrictions and exposure limit values related to human exposure to electromagnetic fields in the frequency range from 300 MHz to 6 GHz: devices used next to the ear</p>
	<p>EN50566: 2017;BS EN50566: 2017 Product standard to demonstrate the compliance of wireless communication devices with the basic restrictions and exposure limit values related to human exposure to electromagnetic fields in the frequency range from 30 MHz to 6 GHz: hand-held and body mounted devices in close proximity to the human body</p>
	<p>EN62209-1:2016;BS EN62209-1:2016 Measurement procedure for the assessment of specific absorption rate of human exposure to radio frequency fields from hand-held and body-mounted wireless communication devices – Part 1: Devices used next to the ear (Frequency range of 300 MHz to 6 GHz)</p>
	<p>EN62209-2:2010;BS EN62209-2:2010 Human exposure to radio frequency fields from hand-held and body-mounted wireless communication devices – Human models, instrumentation, and procedures – Part 2: Procedure to determine the specific absorption rate (SAR) for wireless communication devices used in close proximity to the human body (frequency range of 30 MHz to 6 GHz)</p>
	<p>EN 62479:2010;BS EN 62479:2010 Assessment of the compliance of low power electronic and electrical equipment with the basic restrictions related to human exposure to electromagnetic fields (10 MHz to 300 GHz)</p>
	<p>EN 50663:2017;BS EN 50663:2017 Generic standard for assessment of low power electronic and electrical equipment related to human exposure restrictions for electromagnetic fields (10 MHz - 300 GHz)</p>
	<p>REDCA Technical Guidance Note 20 SAR Testing and Assessment Guidance</p>

Note: This wireless device has been shown to be capable of compliance for localized specific absorption rate (SAR) for General Population/Uncontrolled Exposure limits specified in **Council Recommendation 1999/519/EC** and has been tested in accordance with the measurement procedures specified in EN62209-1:2016 & EN62209-2:2010.

The results and statements contained in this report pertain only to the device(s) evaluated.

TABLE OF CONTENTS

DOCUMENT REVISION HISTORY	6
EUT DESCRIPTION	7
TECHNICAL SPECIFICATION.....	7
REFERENCE, STANDARDS, AND GUIDELINES	8
SAR LIMITS	9
FACILITIES	10
DESCRIPTION OF TEST SYSTEM	11
EQUIPMENT LIST AND CALIBRATION	17
EQUIPMENTS LIST & CALIBRATION INFORMATION	17
SAR MEASUREMENT SYSTEM VERIFICATION	18
LIQUID VERIFICATION.....	18
SYSTEM ACCURACY VERIFICATION	21
SAR SYSTEM VALIDATION DATA	22
EUT TEST STRATEGY AND METHODOLOGY	30
TEST POSITIONS FOR DEVICE OPERATING NEXT TO A PERSON’S EAR.....	30
CHEEK/TOUCH POSITION	31
EAR/TILT POSITION.....	31
TEST POSITIONS FOR BODY-WORN AND OTHER CONFIGURATIONS	32
SAR EVALUATION PROCEDURE	33
TEST METHODOLOGY	33
CONDUCTED OUTPUT POWER MEASUREMENT	34
TEST RESULTS:.....	34
MAXIMUM TARGET OUTPUT POWER.....	43
SAR MEASUREMENT RESULTS	44
TEST RESULTS:.....	44
SAR PLOTS (SUMMARY OF THE HIGHEST SAR VALUES)	63
APPENDIX A MEASUREMENT UNCERTAINTY	99
APPENDIX B PROBE CALIBRATION CERTIFICATES	102
APPENDIX C DIPOLE CALIBRATION CERTIFICATES	111
APPENDIX D EUT TEST POSITION PHOTOS	155
LIQUID DEPTH ≥ 15CM.....	155
HEAD LEFT CHEEK SETUP PHOTO	156
HEAD LEFT TILT SETUP PHOTO.....	156
HEAD RIGHT CHEEK SETUP PHOTO.....	157
HEAD RIGHT TILT SETUP PHOTO	157
BODY (WORN) BACK SETUP PHOTO (5 MM).....	158
BODY FRONT SETUP PHOTO(5 MM).....	158
LIMB BACK SETUP PHOTO (0 MM).....	159
LIMB FRONT SETUP PHOTO(0 MM).....	159
LIMB LEFT SETUP PHOTO (5 MM).....	160
LIMB RIGHT SETUP PHOTO(5 MM)	160
LIMB TOP SETUP PHOTO (0 MM)	161
LIMB BOTTOM SETUP PHOTO(0 MM).....	161
APPENDIX E EUT PHOTOS	162
EUT– FRONT VIEW.....	162
EUT– REAR VIEW.....	162
EUT –MAIN-ANTENNA VIEW	163
EUT –DIV-ANTENNA VIEW	163
EUT – 2.4GWIFI&BT- ANTENNA VIEW	164
EUT – 5GWIFI - ANTENNA VIEW.....	164
APPENDIX F INFORMATIVE REFERENCES	165

DOCUMENT REVISION HISTORY

Revision Number	Report Number	Description of Revision	Date of Revision
0	SZ1230324-14503E-SAA	Original Report	2023/04/25

EUT DESCRIPTION

This report has been prepared on behalf of **Shenzhen Youmi Intelligent Technology Co., Ltd.** and their product **Smart phone**, Model: **G3 Mecha** and **G5 Mecha**, Tested Model: **G3 Mecha** or the EUT (Equipment Under Test) as referred to in the rest of this report.

Note: The models of this product series are G3 Mecha and G5 Mecha, which only differ in the flash module and are otherwise identical. After evaluation, it has been confirmed that this does not affect the SAR value. Therefore, G3 Mecha was chosen for testing.

**All measurement and test data in this report was gathered from production sample serial number: 23N2_1 (Assigned by BACL, Shenzhen). The EUT supplied by the applicant was received on 2022-03-27.*

Technical Specification

Product Type	Portable
Exposure Category:	Population / Uncontrolled
Antenna Type(s):	Internal Antenna
Body-Worn Accessories:	Headset
Face-Head Accessories:	None
Multi-slot Class:	GPRS (Class 12)
Operation Mode :	GSM Voice, GPRS Data, WCDMA, LTE, Wi-Fi, Bluetooth
Frequency Band:	EGSM900: 880-915MHz(TX), 925-960MHz(RX) DCS1800: 1710-1785MHz(TX), 1805-1880MHz(RX) WCDMA 2100: 1920-1980MHz(TX), 2110-2170MHz(RX) WCDMA 900: 880-915MHz(TX), 925-960MHz(RX) LTE Band 1: 1920-1980MHz(TX), 2110-2170MHz(RX) LTE Band 3: 1710-1785MHz(TX), 1805-1880MHz(RX) LTE Band 8: 880-915MHz(TX), 925-960MHz(RX) LTE Band 28: 703-748MHz(TX), 758-803 MHz(RX) LTE Band 40: 2300-2400MHz(TX/RX) 2.4G Wi-Fi: 2412-2472MHz(TX & RX) 5.2G Wi-Fi: 5150-5250MHz(TX & RX) 5.8G Wi-Fi: 5725-5850MHz(TX & RX) Bluetooth: 2402-2480 MHz(TX & RX)
Power Source:	Rechargeable Battery
Normal Operation:	Head ,Body-worn and Limb

REFERENCE, STANDARDS, AND GUIDELINES

FCC:

The Report and Order requires routine SAR evaluation prior to equipment authorization of portable transmitter devices, including portable telephones. For consumer products, the applicable limit is 1.6 mW/g as recommended by the ANSI/IEEE standard C95.1-1992 [6] for an uncontrolled environment (Paragraph 65). According to the Supplement C of OET Bulletin 65 "Evaluating Compliance with FCC Guide-lines for Human Exposure to Radio frequency Electromagnetic Fields", released on Jun 29, 2001 by the FCC, the device should be evaluated at maximum output power (radiated from the antenna) under "worst-case" conditions for normal or intended use, incorporating normal antenna operating positions, device peak performance frequencies and positions for maximum RF energy coupling.

This report describes the methodology and results of experiments performed on wireless data terminal. The objective was to determine if there is RF radiation and if radiation is found, what is the extent of radiation with respect to safety limits. SAR (Specific Absorption Rate) is the measure of RF exposure determined by the amount of RF energy absorbed by human body (or its parts) – to determine how the RF energy couples to the body or head which is a primary health concern for body worn devices. The limit below which the exposure to RF is considered safe by regulatory bodies in North America is 1.6 mW/g average over 1 gram of tissue mass.

CE:

The order requires routine SAR evaluation prior to equipment authorization of portable transmitter devices, including portable telephones. For consumer products, the applicable limit is 2 mW/g as recommended by EN62209-1 for an uncontrolled environment. According to the Standard, the device should be evaluated at maximum output power (radiated from the antenna) under "worst-case" conditions for normal or intended use, incorporating normal antenna operating positions, device peak performance frequencies and positions for maximum RF energy coupling.

This report describes the methodology and results of experiments performed on wireless data terminal. The objective was to determine if there is RF radiation and if radiation is found, what is the extent of radiation with respect to safety limits. SAR (Specific Absorption Rate) is the measure of RF exposure determined by the amount of RF energy absorbed by human body (or its parts) – to determine how the RF energy couples to the body or head which is a primary health concern for body worn devices. The limit below which the exposure to RF is considered safe by regulatory bodies in Europe is 2 mW/g average over 10 gram of tissue mass.

The test configurations were laid out on a specially designed test fixture to ensure the reproducibility of measurements. Each configuration was scanned for SAR. Analysis of each scan was carried out to characterize the above effects in the device.

SAR Limits

CE Limit (10g Tissue)

EXPOSURE LIMITS	SAR (W/kg)	
	(General Population / Uncontrolled Exposure Environment)	(Occupational / Controlled Exposure Environment)
Spatial Average (averaged over the whole body)	0.08	0.4
Spatial Peak (averaged over any 10 g of tissue)	2.0	10
Spatial Peak (hands/wrists/feet/ankles averaged over 10 g)	4.0	20.0

Population/Uncontrolled Environments are defined as locations where there is the exposure of individual who have no knowledge or control of their exposure.

Occupational/Controlled Environments are defined as locations where there is exposure that may be incurred by people who are aware of the potential for exposure (i.e. as a result of employment or occupation).

General Population/Uncontrolled environments SpatialPeak limit 2.0W/kg (Head and Body) & 4.0 W/kg (Limb) applied to the EUT.

FACILITIES

The test site used by Bay Area Compliance Laboratories Corp. (Shenzhen) to collect data is located at 5F(B-West) ,6F,7F,the 3rd Phase of Wan Li Industrial Building D,Shihua Rd, FuTian Free Trade Zone, Shenzhen, China

DESCRIPTION OF TEST SYSTEM

These measurements were performed with the automated near-field scanning system DASY6 from Schmid& Partner Engineering AG (SPEAG) which is the Fifth generation of the system shown in the figure hereinafter:

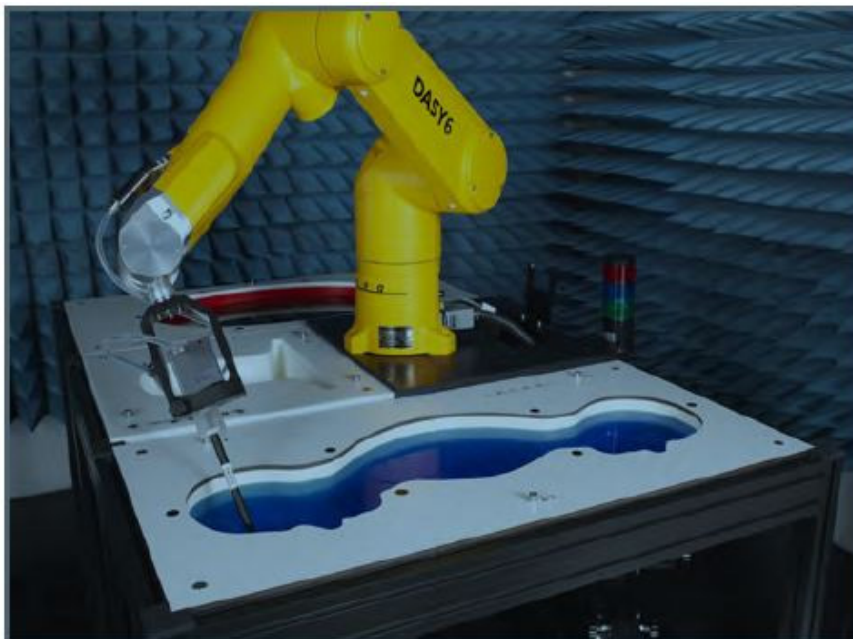

DASY6 System Description

The DASY6 system for performing compliance tests consists of the following items:

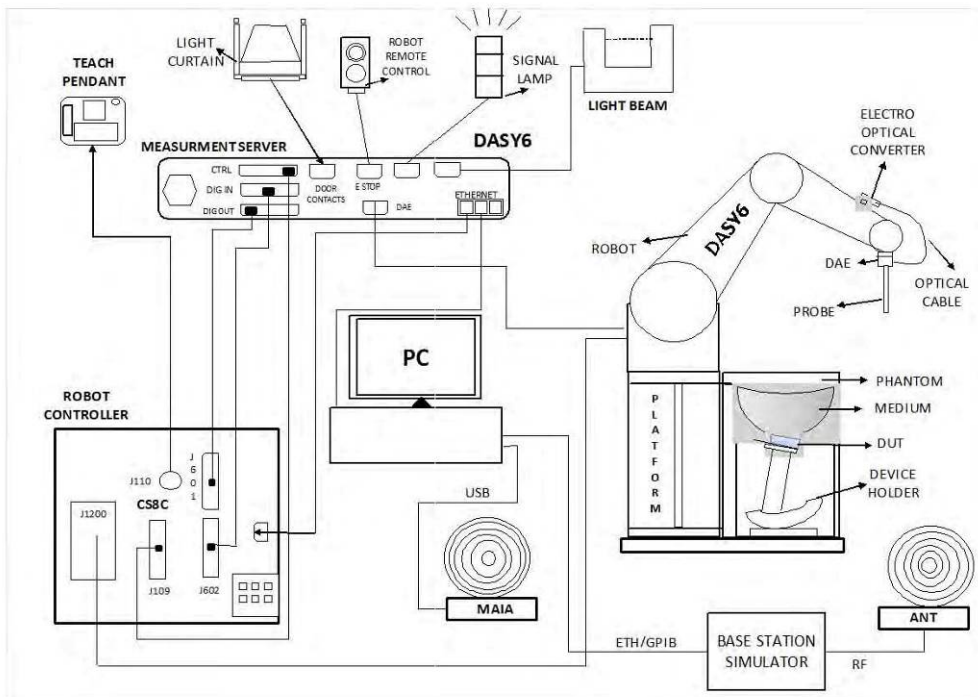

- A standard high precision 6-axis robot (Staubli TX=RX family) with controller, teach pendant and software. An arm extension for accommodating the data acquisition electronics (DAE).
- An isotropic field probe optimized and calibrated for the targeted measurement.
- A data acquisition electronics (DAE) which performs the signal application, signal multiplexing, AD-conversion, offset measurements, mechanical surface detection, collision detection, etc. The unit is battery powered with standard or rechargeable batteries. The signal is optically transmitted to the EOC.
- The Electro-optical converter (EOC) performs the conversion from optical to electrical signals for the digital communication to the DAE. To use optical surface detection, a special version of the EOC is required. The EOC signal is transmitted to the measurement server.
- The function of the measurement server is to perform the time critical tasks such as signal filtering, control of the robot operation and fast movement interrupts.
- The Light Beam used is for probe alignment. This improves the (absolute) accuracy of the probe positioning.
- A computer running Win7 professional operating system and the DASY52 software.
- Remote control and teach pendant as well as additional circuitry for robot safety such as warning lamps, etc.
- The phantom, the device holder and other accessories according to the targeted measurement.

DASY6 Measurement Server

The DASY6 measurement server is based on a PC/104 CPU board with a 400 MHz Intel ULV Celeron, 128 MB chip-disk and 128 MB RAM. The necessary circuits for communication with the DAE4 (or DAE3) electronics box, as well as the 16-bit AD converter system for optical detection and digital I/O interface are contained on the DASY6 I/O board, which is directly connected to the PC/104 bus of the CPU board.



The measurement server performs all real-time data evaluations of field measurements and surface detection, controls robot movements, and handles safety operations. The PC operating system cannot interfere with these time-critical processes. All connections are supervised by a watchdog, and disconnection of any of the cables to the measurement server will automatically disarm the robot and disable all program-controlled robot movements. Furthermore, the measurement server is equipped with an expansion port, which is reserved for future applications. Please note that this expansion port does not have a standardized pinout, and therefore only devices provided by SPEAG can be connected. Connection of devices from any other supplier could seriously damage the measurement server.

Data Acquisition Electronics

The data acquisition electronics (DAE4) consist of a highly sensitive electrometer-grade preamplifier with auto-zeroing, a channel and gain-switching multiplexer, a fast 16 bit AD-converter and a command decoder with a control logic unit. Transmission to the measurement server is accomplished through an optical downlink for data and status information, as well as an optical uplink for commands and the clock.

The mechanical probe mounting device includes two different sensor systems for frontal and sideways probe contacts. They are used for mechanical surface detection and probe collision detection.

The input impedance of both the DAE4 as well as of the DAE3 box is 200M Ω ; the inputs are symmetrical and floating. Common mode rejection is above 80 dB.

EX3DV4 E-Field Probes

Frequency	10 MHz to > 6 GHz Linearity: ± 0.2 dB (30 MHz to 6 GHz)
Directivity	± 0.3 dB in TSL (rotation around probe axis) ± 0.5 dB in TSL (rotation normal to probe axis)
Dynamic Range	10 µW/g to > 100 mW/g Linearity: ± 0.2 dB (noise: typically < 1 µW/g)
Dimensions	Overall length: 337 mm (Tip: 20 mm) Tip diameter: 2.5 mm (Body: 12 mm) Typical distance from probe tip to dipole centers: 1 mm
Application	High precision dosimetric measurements in any exposure scenario (e.g., very strong gradient fields); the only probe that enables compliance testing for frequencies up to 6 GHz with precision of better 30%.
Compatibility	DASY3, DASY4, DASY52 SAR and higher, EASY4/MRI

SAM Twin Phantom

The SAM Twin Phantom (shown in front of DASY6) is a fiberglass shell phantom with shell thickness 2 mm, except in the ear region where the thickness is increased to 6 mm. The phantom has three measurement areas: 1) Left Head, 2) Right Head, and 3) Flat Section. For larger devices, the use of the ELI-Phantom (shown behind DASY6) is required. For devices such as glasses with a wireless link, the Face Down Phantom is the most suitable (between the SAM Twin and ELI phantoms).

When the phantom is mounted inside allocated slot of the DASY6 platform, phantom reference points can be taught directly in the DASY5 V5.2 software. When the DASY6 platform is used to mount the

Phantom, some of the phantom teaching points cannot be reached by the robot in DASY5 V5.2. A special tool called P1a-P2aX-Former is provided to transform two of the three points, P1 and P2, to reachable locations. To use these new teaching points, a revised phantom configuration file is required.

In addition to our standard broadband liquids, the phantom can be used with the following tissue simulating liquids:

Sugar-water-based liquids can be left permanently in the phantom. Always cover the liquid when the system is not in use to prevent changes in liquid parameters due to water evaporation.

DGBE-based liquids should be used with care. As DGBE is a softener for most plastics, the liquid should be taken out of the phantom, and the phantom should be dried when the system is not in use (desirable at least once a week).

Do not use other organic solvents without previously testing the solvent resistivity of the phantom. Approximately 25 liters of liquid is required to fill the SAM Twin phantom.

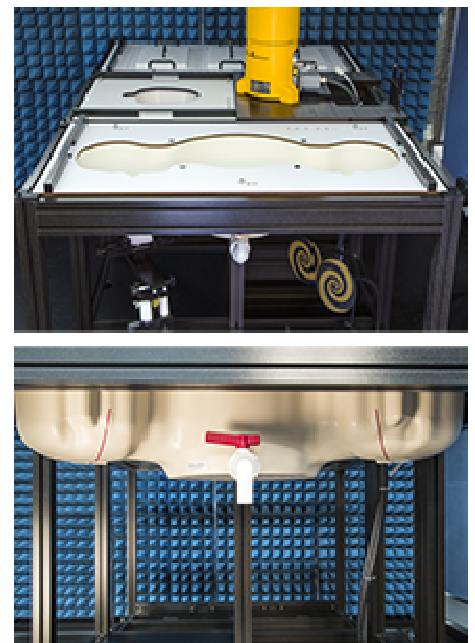

ELI Phantom

The ELI phantom is intended for compliance testing of handheld and body-mounted wireless devices in the frequency range of 30MHz to 6 GHz. ELI is fully compatible with the latest draft of the standard IEC 62209-2 and the use of all known tissue simulating liquids. ELI has been optimized for performance and can be integrated into a SPEAG standard phantom table. A cover is provided to prevent evaporation of water and changes in liquid parameters. Reference markings on the phantom allow installation of the complete setup, including all predefined phantom positions and measurement grids, by teaching three points.

The phantom can be used with the following tissue simulating liquids:

- Sugar-water-based liquids can be left permanently in the phantom. Always cover the liquid when the system is not in use to prevent changes in liquid parameters due to water evaporation.
- DGBE-based liquids should be used with care. As DGBE is a softener for most plastics, the liquid should be taken out of the phantom, and the phantom should be dried when the system is not in use (desirable at least once a week).
- Do not use other organic solvents without previously testing the solvent resistivity of the phantom.

Approximately 25 liters of liquid is required to fill the ELI phantom.

Robots

The DASY6 system uses the high-precision industrial robots TX60L, TX90XL, and RX160L from Staubli SA (France). The TX robot family - the successor of the well-known RX robot family - continues to offer the features important for DASY6 applications:

- High precision (repeatability 0.02mm)
- High reliability (industrial design)
- Low maintenance costs (virtually maintenance free due to direct drive gears; no belt drives)
- Jerk-free straight movements (brushless synchrony motors; no stepper motors)
- Low ELF interference (motor control fields shielded via the closed metallic construction shields)

The robots are controlled by the Staubli CS8c robot controllers. All information regarding the use and maintenance of the robot arm and the robot controller is provided

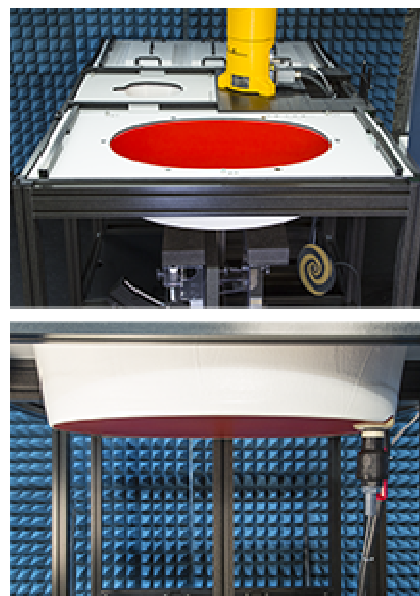

Calibration Frequency Points for EX3DV4 E-Field Probes SN: 3701 Calibrated: 2023/03/15

Calibration Frequency Point(MHz)	Frequency Range(MHz)		Conversion Factor		
	From	To	X	Y	Z
750 Head	650	850	9.71	9.71	9.71
900 Head	850	1000	9.25	9.25	9.25
1750 Head	1650	1850	7.97	7.97	7.97
1900 Head	1850	2000	7.65	7.65	7.65
2300 Head	2200	2400	7.50	7.50	7.50
2450 Head	2400	2550	7.25	7.25	7.25
2600 Head	2550	2700	7.03	7.03	7.03
5250 Head	5140	5360	5.30	5.30	5.30
5600 Head	5390	5700	4.80	4.80	4.80
5750 Head	5640	5860	4.82	4.82	4.82

Area Scans

Area scans are defined prior to the measurement process being executed with a user defined variable spacing between each measurement point (integral) allowing low uncertainty measurements to be conducted. Scans defined for FCC applications utilize a 15mm² step integral, with 1.5mm interpolation used to locate the peak SAR area used for zoom scan assessments.

Where the system identifies multiple SAR peaks (which are within 25% of peak value) the system will provide the user with the option of assessing each peak location individually for zoom scan averaging.

Zoom Scan (Cube Scan Averaging)

The averaging zoom scan volume utilized in the DASY5 software is in the shape of a cube and the side dimension of a 1 g or 10 g mass is dependent on the density of the liquid representing the simulated tissue. A density of 1000 kg/m³ is used to represent the head and body tissue density and not the phantom liquid density, in order to be consistent with the definition of the liquid dielectric properties, i.e. the side length of the 1g cube is 10mm, with the side length of the 10g cube is 21.5mm.

When the cube intersects with the surface of the phantom, it is oriented so that 3 vertices touch the surface of the shell or the center of a face is tangent to the surface. The face of the cube closest to the surface is modified in order to conform to the tangent surface.

The zoom scan integer steps can be user defined so as to reduce uncertainty, but normal practice for typical test applications (including FCC) utilize a physical step of 7 x 7 x 7 (5mmx5mmx5mm) providing a volume of 30 mm in the X & Y & Z axis.

Tissue Dielectric Parameters for Head and Body Phantoms

The head tissue dielectric parameters recommended by the EN 62209-1:2016

Recommended Tissue Dielectric Parameters for Head liquid

Table A.3 – Dielectric properties of the head tissue-equivalent liquid

Frequency MHz	Relative permittivity ϵ_r	Conductivity (σ) S/m
300	45,3	0,87
450	43,5	0,87
<i>750</i>	<i>41,9</i>	<i>0,89</i>
835	41,5	0,90
900	41,5	0,97
1 450	40,5	1,20
<i>1 500</i>	<i>40,4</i>	<i>1,23</i>
<i>1 640</i>	<i>40,2</i>	<i>1,31</i>
<i>1 750</i>	<i>40,1</i>	<i>1,37</i>
1 800	40,0	1,40
1 900	40,0	1,40
2 000	40,0	1,40
<i>2 100</i>	<i>39,8</i>	<i>1,49</i>
<i>2 300</i>	<i>39,5</i>	<i>1,67</i>
2 450	39,2	1,80
<i>2 600</i>	<i>39,0</i>	<i>1,96</i>
3 000	38,5	2,40
<i>3 500</i>	<i>37,9</i>	<i>2,91</i>
<i>4 000</i>	<i>37,4</i>	<i>3,43</i>
<i>4 500</i>	<i>36,8</i>	<i>3,94</i>
<i>5 000</i>	<i>36,2</i>	<i>4,45</i>
<i>5 200</i>	<i>36,0</i>	<i>4,66</i>
<i>5 400</i>	<i>35,8</i>	<i>4,86</i>
<i>5 600</i>	<i>35,5</i>	<i>5,07</i>
<i>5 800</i>	<i>35,3</i>	<i>5,27</i>
<i>6 000</i>	<i>35,1</i>	<i>5,48</i>

NOTE For convenience, permittivity and conductivity values at those frequencies which are not part of the original data provided by Drossos et al. [33] or the extension to 5 800 MHz are provided (i.e. the values shown *in italics*). These values were linearly interpolated between the values in this table that are immediately above and below these values, except the values at 6 000 MHz that were linearly extrapolated from the values at 3 000 MHz and 5 800 MHz.

EQUIPMENT LIST AND CALIBRATION

Equipments List & Calibration Information

Equipment	Model	S/N	Calibration Date	Calibration Due Date
DASY5 Test Software	DASY52 52.10.2	N/A	NCR	NCR
DASY6 Measurement Server	DASY6 6.0.31	N/A	NCR	NCR
Data Acquisition Electronics	DAE4	1325	2022/08/29	2023/08/28
E-Field Probe	EX3DV4	3701	2023/03/15	2024/03/14
Mounting Device	MD4HHTV5	SD 000 H01 KA	NCR	NCR
SAM Twin Phantom	SAM-Twin V8.0	1962	NCR	NCR
Dipole,750MHz	D750V3	1229	2023/03/24	2026/03/23
Dipole,900MHz	D900V2	132	2020/10/15	2023/10/14
Dipole,1750MHz	D1750V2	1199	2023/03/27	2026/03/26
Dipole,1900MHz	D1900V2	5d231	2023/02/17	2026/02/16
Dipole, 2300MHz	D2300V2	1136	2023/03/27	2026/03/26
Dipole,2450MHz	D2450V2	1103	2023/03/27	2026/03/26
Dipole,5GHz	D5GHZV2	1374	2023/03/27	2026/03/26
Simulated Tissue Liquid Head	HBBL600-10000V6	180622-2	Each Time	/
Network Analyzer	8753D	3410A08288	2022/07/05	2023/07/04
Dielectric Assessment Kit	DAK-3.5	1248	NCR	NCR
MXG Analog Signal Generator	N5181A	MY48180408	2022/07/05	2023/07/04
USB wideband power sensor	U2021XA	MY52350001	2022/06/27	2023/06/26
Power Amplifier	5S1G4	71377	NCR	NCR
Directional Coupler	4242-10	3307	NCR	NCR
Attenuator	6dB	773-6	NCR	NCR
WIDEBAND RADIO COMMUNICATION TESTER	CMW500	146520	2022/06/27	2023/06/26

NCR:No Calibration Required.

SAR MEASUREMENT SYSTEM VERIFICATION

Liquid Verification

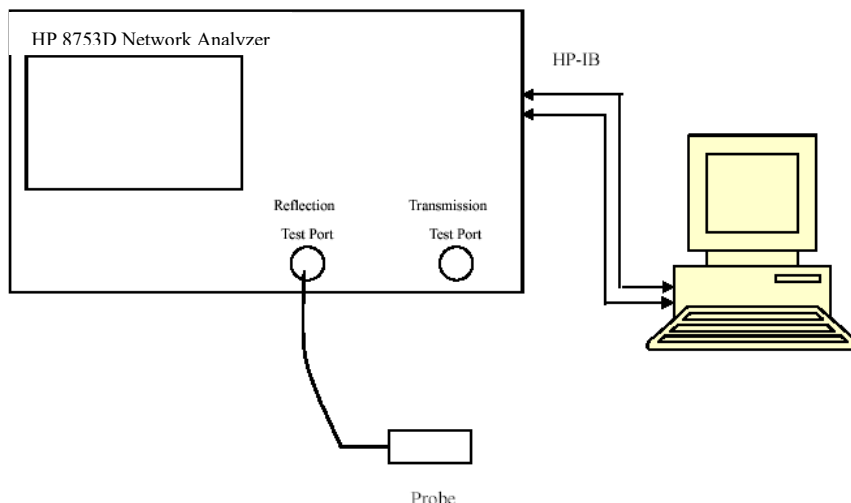

Liquid Verification Setup Block Diagram

Liquid Verification Results

Frequency (MHz)	LiquidType	Liquid Parameter		Target Value		Delta (%)		Tolerance (%)
		ϵ_r	σ (S/m)	ϵ_r	σ (S/m)	$\Delta\epsilon_r$	$\Delta\sigma$	
713	Simulated Tissue Liquid Head	42.614	0.902	42.10	0.89	1.22	1.35	±5
728	Simulated Tissue Liquid Head	42.326	0.906	42.02	0.89	0.73	1.80	±5
738	Simulated Tissue Liquid Head	42.134	0.908	41.96	0.89	0.41	2.02	±5
750	Simulated Tissue Liquid Head	41.903	0.910	41.90	0.89	0.01	2.25	±5

*Liquid Verification was performed on 2023/04/18.

Frequency (MHz)	LiquidType	Liquid Parameter		Target Value		Delta (%)		Tolerance (%)
		ϵ_r	σ (S/m)	ϵ_r	σ (S/m)	$\Delta\epsilon_r$	$\Delta\sigma$	
880.2	Simulated Tissue Liquid Head	42.231	0.934	41.50	0.95	1.76	-1.68	±5
882.6	Simulated Tissue Liquid Head	42.196	0.935	41.50	0.95	1.68	-1.58	±5
885	Simulated Tissue Liquid Head	42.161	0.937	41.50	0.95	1.59	-1.37	±5
897.5	Simulated Tissue Liquid Head	41.980	0.942	41.50	0.97	1.16	-2.89	±5
897.6	Simulated Tissue Liquid Head	41.978	0.942	41.50	0.97	1.15	-2.89	±5
900	Simulated Tissue Liquid Head	41.943	0.943	41.50	0.97	1.07	-2.78	±5
902	Simulated Tissue Liquid Head	41.964	0.946	41.50	0.97	1.12	-2.47	±5
910	Simulated Tissue Liquid Head	42.045	0.955	41.48	0.97	1.36	-1.55	±5
912.4	Simulated Tissue Liquid Head	42.069	0.957	41.48	0.98	1.42	-2.35	±5
914.8	Simulated Tissue Liquid Head	42.094	0.960	41.47	0.98	1.50	-2.04	±5

*Liquid Verification was performed on 2023/04/08.

Frequency (MHz)	LiquidType	Liquid Parameter		Target Value		Delta (%)		Tolerance (%)
		ϵ_r	σ (S/m)	ϵ_r	σ (S/m)	$\Delta\epsilon_r$	$\Delta\sigma$	
1710.4	Simulated Tissue Liquid Head	41.247	1.380	40.14	1.35	2.76	2.22	±5
1720	Simulated Tissue Liquid Head	41.220	1.389	40.13	1.35	2.72	2.89	±5
1747.5	Simulated Tissue Liquid Head	41.143	1.414	40.10	1.37	2.60	3.21	±5
1747.8	Simulated Tissue Liquid Head	41.142	1.414	40.10	1.37	2.60	3.21	±5
1750	Simulated Tissue Liquid Head	41.136	1.416	40.10	1.37	2.58	3.36	±5
1775	Simulated Tissue Liquid Head	40.921	1.416	40.05	1.39	2.17	1.87	±5
1784.6	Simulated Tissue Liquid Head	40.839	1.416	40.03	1.39	2.02	1.87	±5

*Liquid Verification was performed on 2023/04/09.

Frequency (MHz)	LiquidType	Liquid Parameter		Target Value		Delta (%)		Tolerance (%)
		ϵ_r	σ (S/m)	ϵ_r	σ (S/m)	$\Delta\epsilon_r$	$\Delta\sigma$	
1900	Simulated Tissue Liquid Head	40.248	1.417	40.00	1.40	0.62	1.21	±5
1922.6	Simulated Tissue Liquid Head	40.710	1.380	40.00	1.40	1.78	-1.43	±5
1930	Simulated Tissue Liquid Head	40.861	1.368	40.00	1.40	2.15	-2.29	±5
1950	Simulated Tissue Liquid Head	41.270	1.334	40.00	1.40	3.18	-4.71	±5
1970	Simulated Tissue Liquid Head	41.197	1.350	40.00	1.40	2.99	-3.57	±5
1977.4	Simulated Tissue Liquid Head	41.170	1.356	40.00	1.40	2.93	-3.14	±5

*Liquid Verification was performed on 2023/04/10.

Frequency (MHz)	LiquidType	Liquid Parameter		Target Value		Delta (%)		Tolerance (%)
		ϵ_r	σ (S/m)	ϵ_r	σ (S/m)	$\Delta\epsilon_r$	$\Delta\sigma$	
2300	Simulated Tissue Liquid Head	40.006	1.715	39.50	1.67	1.28	2.69	±5
2310	Simulated Tissue Liquid Head	40.216	1.719	39.48	1.68	1.86	2.32	±5
2350	Simulated Tissue Liquid Head	41.055	1.736	39.40	1.71	4.20	1.52	±5
2390	Simulated Tissue Liquid Head	40.436	1.779	39.32	1.75	2.84	1.66	±5

*Liquid Verification was performed on 2023/04/18.

Frequency (MHz)	LiquidType	Liquid Parameter		Target Value		Delta (%)		Tolerance (%)
		ϵ_r	σ (S/m)	ϵ_r	σ (S/m)	$\Delta\epsilon_r$	$\Delta\sigma$	
2412	Simulated Tissue Liquid Head	40.237	1.805	39.28	1.77	2.44	1.98	±5
2442	Simulated Tissue Liquid Head	40.128	1.845	39.22	1.79	2.32	3.07	±5
2450	Simulated Tissue Liquid Head	40.099	1.855	39.20	1.80	2.29	3.06	±5
2472	Simulated Tissue Liquid Head	40.325	1.862	39.17	1.82	2.95	2.31	±5

*Liquid Verification was performed on 2023/04/12.

Frequency (MHz)	LiquidType	Liquid Parameter		Target Value		Delta (%)		Tolerance (%)
		ϵ_r	σ (S/m)	ϵ_r	σ (S/m)	$\Delta\epsilon_r$	$\Delta\sigma$	
5180	Simulated Tissue Liquid Head	36.650	4.727	36.02	4.64	1.75	1.88	±5
5200	Simulated Tissue Liquid Head	36.783	4.700	36.00	4.66	2.18	0.86	±5
5240	Simulated Tissue Liquid Head	37.445	4.687	35.96	4.70	4.13	-0.28	±5
5250	Simulated Tissue Liquid Head	37.610	4.684	35.95	4.71	4.62	-0.55	±5

*Liquid Verification was performed on 2023/04/11.

Frequency (MHz)	LiquidType	Liquid Parameter		Target Value		Delta (%)		Tolerance (%)
		ϵ_r	σ (S/m)	ϵ_r	σ (S/m)	$\Delta\epsilon_r$	$\Delta\sigma$	
5745	Simulated Tissue Liquid Head	36.173	5.229	35.36	5.22	2.30	0.17	±5
5750	Simulated Tissue Liquid Head	36.223	5.241	35.35	5.22	2.47	0.40	±5
5785	Simulated Tissue Liquid Head	36.222	5.270	35.32	5.26	2.55	0.19	±5
5825	Simulated Tissue Liquid Head	36.341	5.264	35.28	5.30	3.01	-0.68	±5

*Liquid Verification was performed on 2023/04/19.

System Accuracy Verification

Prior to the assessment, the system validation kit was used to test whether the system was operating within its specifications of $\pm 10\%$. The validation results are tabulated below. And also the corresponding SAR plot is attached as well in the SAR plots files.

The spacing distances in the **System Verification Setup Block Diagram** is given by the following:

- a) $s = 15 \text{ mm} \pm 0,2 \text{ mm}$ for $300 \text{ MHz} \leq f \leq 1\,000 \text{ MHz}$;
- b) $s = 10 \text{ mm} \pm 0,2 \text{ mm}$ for $1\,000 \text{ MHz} < f \leq 3\,000 \text{ MHz}$;
- c) $s = 10 \text{ mm} \pm 0,2 \text{ mm}$ for $3\,000 \text{ MHz} < f \leq 6\,000 \text{ MHz}$.

System Verification Setup Block Diagram

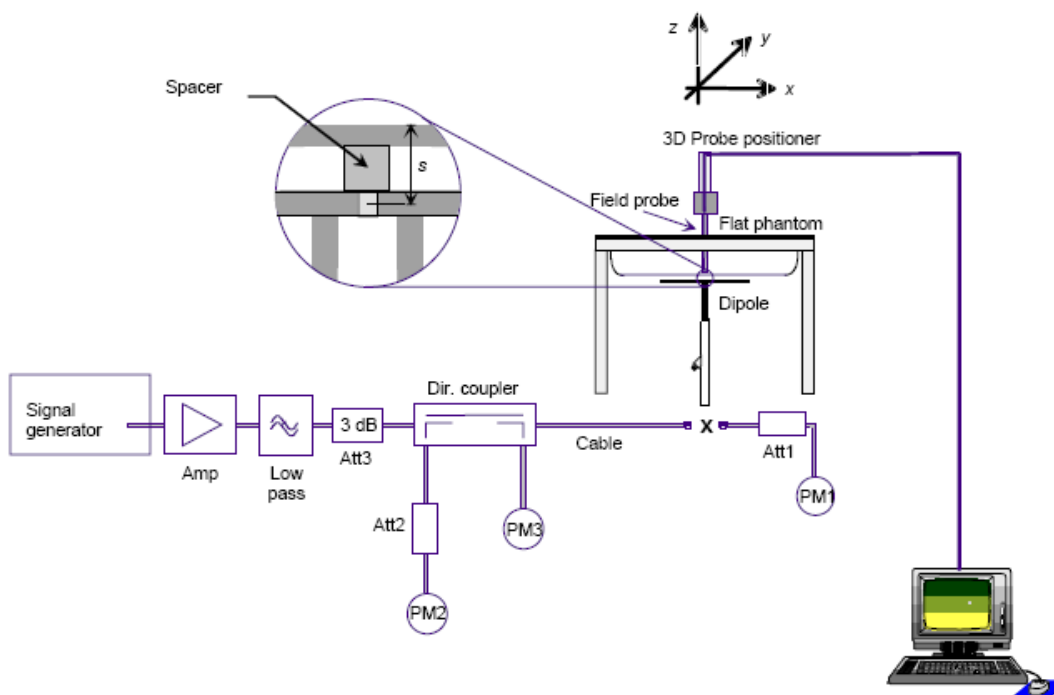

System Accuracy Check Results

Date	Frequency Band (MHz)	Liquid Type	Input Power (mW)	Measured SAR (W/kg)	Normalized to 1W (W/kg)	Target Value (W/Kg)	Delta (%)	Tolerance (%)
2023/04/18	750	Head	100	10g 0.553	5.53	5.46	1.282	± 10
2023/04/08	900	Head	100	10g 0.745	7.45	7.1	4.930	± 10
2023/04/09	1800	Head	100	10g 1.90	19.0	18.9	0.529	± 10
2023/04/10	1900	Head	100	10g 2.04	20.4	20.8	-1.923	± 10
2023/04/18	2300	Head	100	10g 2.36	23.6	23.5	0.426	± 10
2023/04/12	2450	Head	100	10g 2.58	25.8	24.2	6.612	± 10
2023/04/11	5250	Head	100	10g 2.38	23.8	23.1	3.030	± 10
2023/04/19	5750	Head	100	10g 2.47	24.7	23	7.391	± 10

Note:
All the SAR values are normalized to 1 Watt forward power.

SAR SYSTEM VALIDATION DATA

System Performance 750 MHz Head

DUT: Dipole 750 MHz; Type: D750V3; Serial: 1229

Communication System: UID 0, CW (0); Frequency: 750 MHz; Duty Cycle: 1:1

Medium parameters used: $f = 750$ MHz; $\sigma = 0.91$ S/m; $\epsilon_r = 41.903$; $\rho = 1000$ kg/m³

Phantom section: Flat Section

DASY5 Configuration:

- Probe: EX3DV4 – SN3701; ConvF(9.71, 9.71, 9.71) @ 750 MHz;
- Sensor-Surface: 4mm (Mechanical Surface Detection)
- Electronics: DAE4 Sn1325; Calibrated: 8/29/2022
- Phantom: SAM-Twin V8.0 P1aP2a; Type: QD 000 P41 AA ; Serial: 1962
- Measurement SW: DASY52, Version 52.10 (2);

Head 750MHz Pin=100mW/Area Scan (7x12x1): Measurement grid: dx=15 mm, dy=15 mm

Maximum value of SAR (measured) = 0.952 W/kg

Head 750MHz Pin=100mW/Zoom Scan (7x7x7)/Cube 0: Measurement grid: dx=5mm, dy=5mm, dz=5mm

Reference Value = 32.68 V/m; Power Drift = 0.10 dB

Peak SAR (extrapolated) = 1.26 W/kg

SAR(1 g) = 0.854 W/kg; SAR(10 g) = 0.553 W/kg

Maximum value of SAR (measured) = 0.972 W/kg

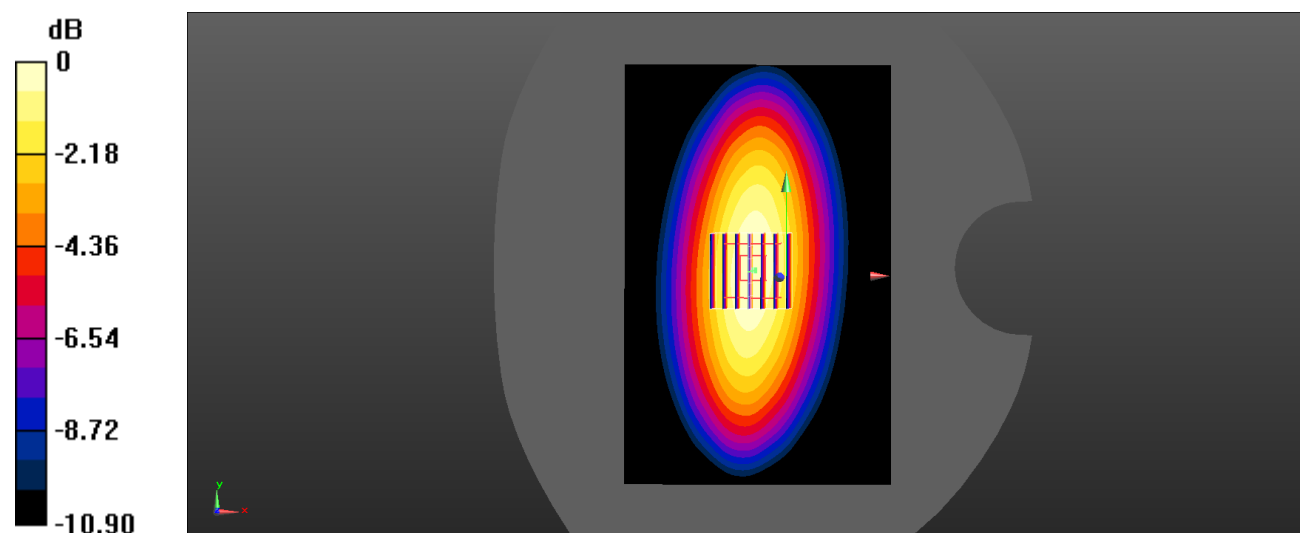

0 dB = 0.972 W/kg = -0.12 dBW/kg

System Performance 900 MHz Head

DUT: Dipole 900 MHz; Type: D900V2; Serial: 132

Communication System: UID 0, CW (0); Frequency: 900 MHz; Duty Cycle: 1:1

Medium parameters used: $f = 900 \text{ MHz}$; $\sigma = 0.943 \text{ S/m}$; $\epsilon_r = 41.943$; $\rho = 1000 \text{ kg/m}^3$

Phantom section: Flat Section

DASY5 Configuration:

- Probe: EX3DV4 – SN3701; ConvF(9.25, 9.25, 9.25) @ 900 MHz;
- Sensor-Surface: 4mm (Mechanical Surface Detection)
- Electronics: DAE4 Sn1325; Calibrated: 8/29/2022
- Phantom: SAM-Twin V8.0 P1aP2a; Type: QD 000 P41 AA ; Serial: 1962
- Measurement SW: DASY52, Version 52.10 (2);

Head 900MHz Pin=100mW/Area Scan (10x14x1): Measurement grid: $dx=10 \text{ mm}$, $dy=10 \text{ mm}$

Maximum value of SAR (measured) = 1.41 W/kg

Head 900MHz Pin=100mW/Zoom Scan (7x7x7)/Cube 0: Measurement grid: $dx=5\text{mm}$, $dy=5\text{mm}$, $dz=5\text{mm}$

Reference Value = 36.38 V/m; Power Drift = -0.08 dB

Peak SAR (extrapolated) = 1.59 W/kg

SAR(1 g) = 1.04 W/kg; SAR(10 g) = 0.745 W/kg

Maximum value of SAR (measured) = 1.18 W/kg

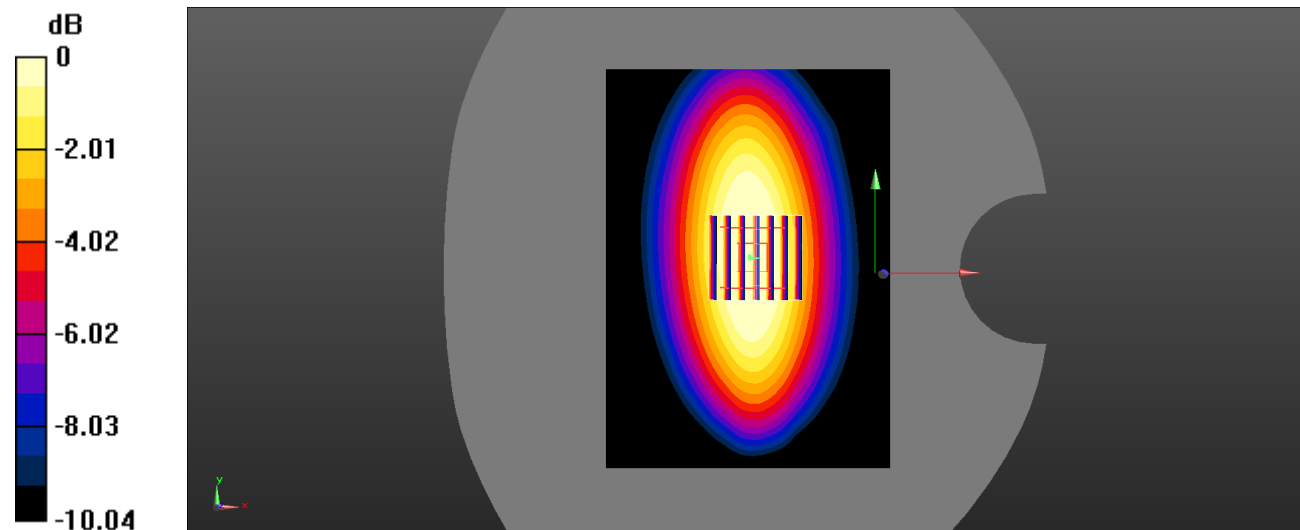

0 dB = 1.18 W/kg = 0.70 dBW/kg

System Performance 1750 MHz Head

DUT: Dipole 1750 MHz; Type: D1750V2; Serial: 1199

Communication System: UID 0, CW (0); Frequency: 1800 MHz;Duty Cycle: 1:1
 Medium parameters used: $f = 1750 \text{ MHz}$; $\sigma = 1.416 \text{ S/m}$; $\epsilon_r = 41.136$; $\rho = 1000 \text{ kg/m}^3$
 Phantom section: Flat Section

DASY5 Configuration:

- Probe: EX3DV4 – SN3701; ConvF(7.97, 7.97, 7.97) @ 1750 MHz;
- Sensor-Surface: 4mm (Mechanical Surface Detection)
- Electronics: DAE4 Sn1325; Calibrated: 8/29/2022
- Phantom: SAM-Twin V8.0 P1aP2a; Type: QD 000 P41 AA ; Serial: 1962
- Measurement SW: DASY52, Version 52.10 (2);

Head 1750MHz Pin=100mW/Area Scan (8x10x1): Measurement grid: dx=12 mm, dy=12 mm

Maximum value of SAR (measured) = 5.93 W/kg

Head 1750MHz Pin=100mW/Zoom Scan (7x7x7)/Cube 0: Measurement grid: dx=5mm, dy=5mm, dz=5mm

Reference Value = 43.84 V/m; Power Drift = 0.16 dB

Peak SAR (extrapolated) = 9.92 W/kg

SAR(1 g) = 3.55 W/kg; SAR(10 g) = 1.90 W/kg

Maximum value of SAR (measured) = 5.29 W/kg

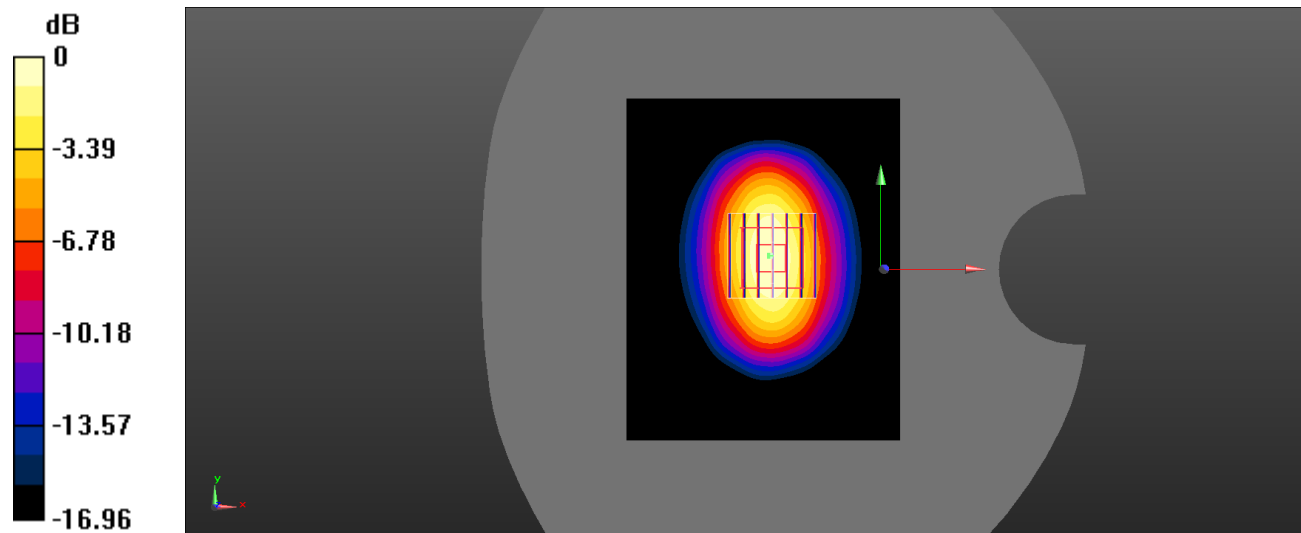

0 dB = 5.29 W/kg = 7.23 dBW/kg

System Performance 1900 MHz Head

DUT: Dipole 1900 MHz; Type: D1900V2; Serial: 5d231

Communication System: UID 0, CW (0); Frequency: 1900 MHz;Duty Cycle: 1:1
 Medium parameters used: f = 1900 MHz; $\sigma = 1.417$ S/m; $\epsilon_r = 40.248$; $\rho = 1000$ kg/m³
 Phantom section: Flat Section

DASY5 Configuration:

- Probe: EX3DV4 – SN3701; ConvF(7.65, 7.65, 7.65) @ 1900 MHz;
- Sensor-Surface: 4mm (Mechanical Surface Detection)
- Electronics: DAE4 Sn1325; Calibrated: 8/29/2022
- Phantom: SAM-Twin V8.0 P1aP2a; Type: QD 000 P41 AA ; Serial: 1962
- Measurement SW: DASY52, Version 52.10 (2);

Head 1900MHz Pin=100mW/Area Scan (6x9x1): Measurement grid: dx=15 mm, dy=15 mm

Maximum value of SAR (measured) = 5.75 W/kg

Head 1900MHz Pin=100mW/Zoom Scan (5x5x7)/Cube 0: Measurement grid: dx=5mm, dy=5mm, dz=5mm

Reference Value = 44.90 V/m; Power Drift = -0.10 dB

Peak SAR (extrapolated) = 8.66 W/kg

SAR(1 g) = 4.01 W/kg; SAR(10 g) = 2.04 W/kg

Maximum value of SAR (measured) = 5.43 W/kg

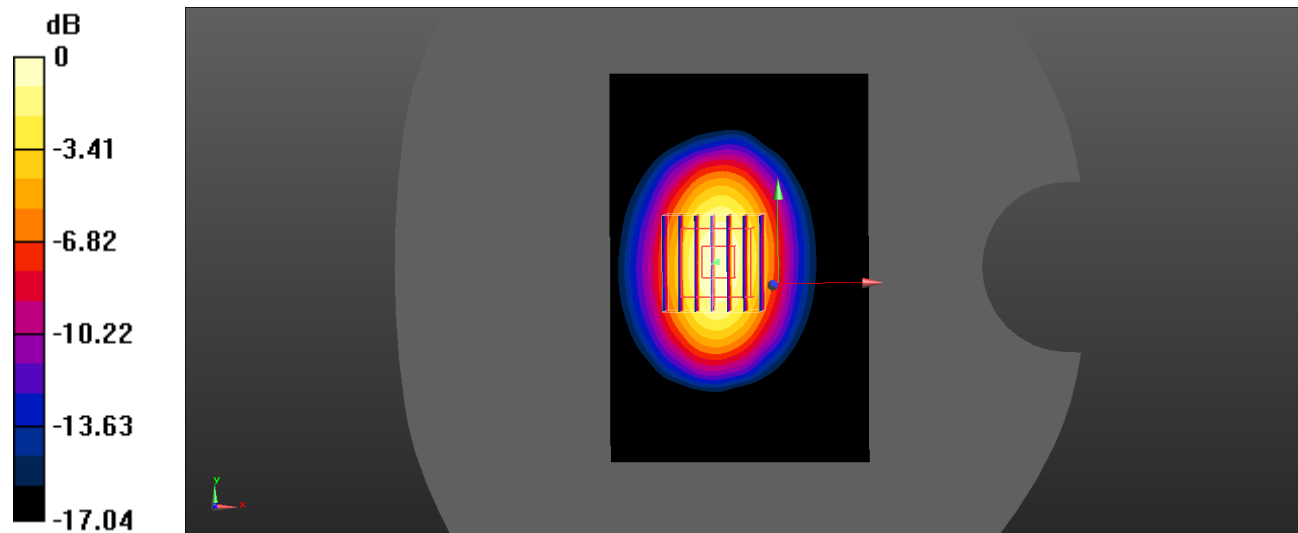

0 dB = 5.43 W/kg = 7.34 dBW/kg

System Performance 2300 MHz Head

DUT: Dipole 2300 MHz; Type: D2300V2; Serial: 1136

Communication System: UID 0, CW (0); Frequency: 2300 MHz; Duty Cycle: 1:1

Medium parameters used: $f = 2300$ MHz; $\sigma = 1.715$ S/m; $\epsilon_r = 40.006$; $\rho = 1000$ kg/m³

Phantom section: Flat Section

DASY5 Configuration:

- Probe: EX3DV4 – SN3701; ConvF(7.5, 7.5, 7.5) @ 2300 MHz;
- Sensor-Surface: 4mm (Mechanical Surface Detection)
- Electronics: DAE4 Sn1325; Calibrated: 8/29/2022
- Phantom: SAM-Twin V8.0 P1aP2a; Type: QD 000 P41 AA ; Serial: 1962
- Measurement SW: DASY52, Version 52.10 (2);

Head 2300MHz Pin=100mW/Area Scan (10x14x1): Measurement grid: dx=10 mm, dy=10 mm

Maximum value of SAR (measured) = 6.36 W/kg

Head 2300MHz Pin=100mW/Zoom Scan (7x7x7)/Cube 0: Measurement grid: dx=5mm, dy=5mm, dz=5mm

Reference Value = 50.27 V/m; Power Drift = 0.10 dB

Peak SAR (extrapolated) = 10.08 W/kg

SAR(1 g) = 5.05 W/kg; SAR(10 g) = 2.36 W/kg

Maximum value of SAR (measured) = 6.02 W/kg

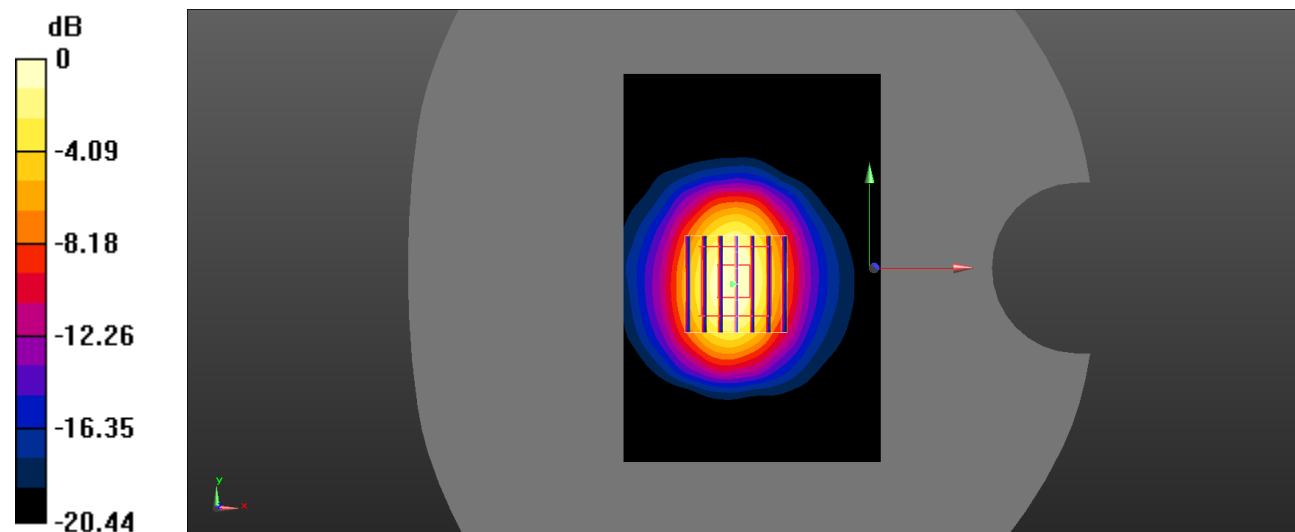

0 dB = 6.02 W/kg = 7.80 dBW/kg

System Performance 2450 MHz Head

DUT: Dipole 2450 MHz; Type: 2450; Serial: 1103

Communication System: UID 0, CW (0); Frequency: 2450 MHz;Duty Cycle: 1:1
 Medium parameters used: f = 2450 MHz; $\sigma = 1.855$ S/m; $\epsilon_r = 40.099$; $\rho = 1000$ kg/m³
 Phantom section: Flat Section

DASY5 Configuration:

- Probe: EX3DV4 – SN3701; ConvF(7.25, 7.25, 7.25) @ 2450 MHz;
- Sensor-Surface: 4mm (Mechanical Surface Detection)
- Electronics: DAE4 Sn1325; Calibrated: 8/29/2022
- Phantom: SAM-Twin V8.0 P1aP2a; Type: QD 000 P41 AA ; Serial: 1962
- Measurement SW: DASY52, Version 52.10 (2);

Head 2450MHz Pin=100mW/Area Scan (8x12x1): Measurement grid: dx=10 mm, dy=10 mm
 Maximum value of SAR (measured) = 7.11 W/kg

Head 2450MHz Pin=100mW/Zoom Scan (7x7x7)/Cube 0: Measurement grid: dx=5mm, dy=5mm, dz=5mm
 Reference Value = 51.17 V/m; Power Drift = 0.17 dB
 Peak SAR (extrapolated) = 12.6 W/kg
SAR(1 g) = 5.06 W/kg; SAR(10 g) = 2.58 W/kg
 Maximum value of SAR (measured) = 6.88 W/kg

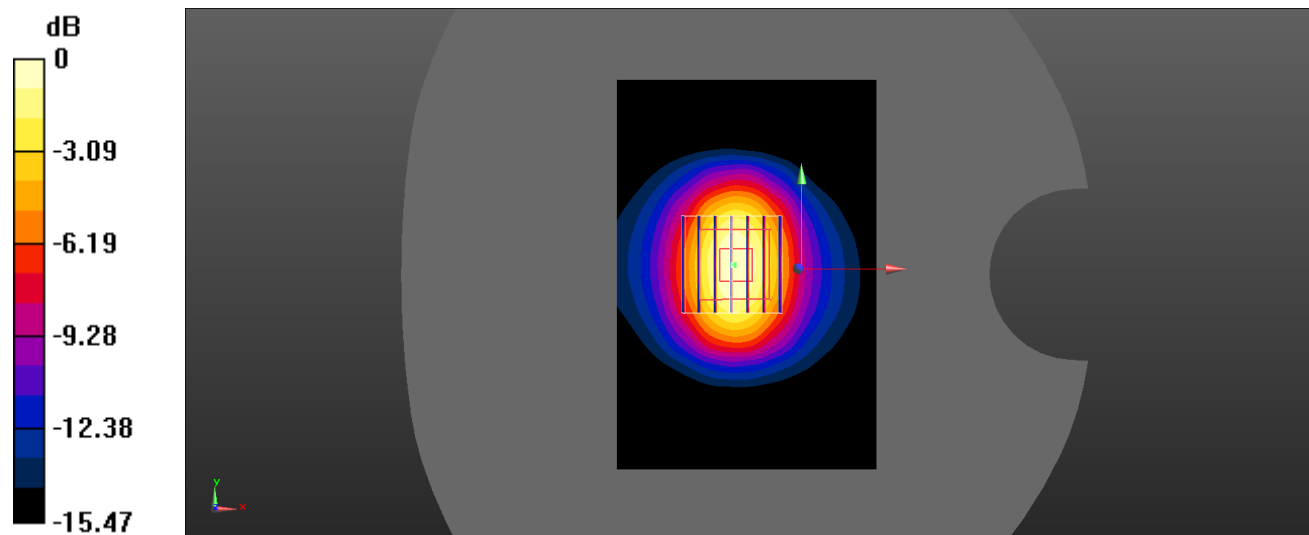

0 dB = 6.88 W/kg = 8.38 dBW/kg

System Performance 5250 MHz Head

DUT: Dipole 5GHz Type: D5GHZV2; Serial: 1374

Communication System: UID 0, CW (0); Frequency: 5250 MHz;Duty Cycle: 1:1

Medium parameters used: $f = 5250 \text{ MHz}$; $\sigma = 4.684 \text{ S/m}$; $\epsilon_r = 37.61$; $\rho = 1000 \text{ kg/m}^3$

Phantom section: Flat Section

DASY5 Configuration:

- Probe: EX3DV4 – SN3701; ConvF(5.3, 5.3, 5.3) @ 5250 MHz;
- Sensor-Surface: 2mm (Mechanical Surface Detection)
- Electronics: DAE4 Sn1325; Calibrated: 8/29/2022
- Phantom: SAM-Twin V8.0 P1aP2a; Type: QD 000 P41 AA ; Serial: 1962
- Measurement SW: DASY52, Version 52.10 (2);

Head 5250MHz Pin=100mW/Area Scan (7x9x1): Measurement grid: dx=10 mm, dy=10 mm

Maximum value of SAR (measured) = 16.9 W/kg

Head 5250MHz Pin=100mW/Zoom Scan (8x8x12)/Cube 0: Measurement grid: dx=4mm, dy=4mm, dz=2mm

Reference Value = 51.40 V/m; Power Drift = 0.03 dB

Peak SAR (extrapolated) = 27.6 W/kg

SAR(1 g) = 7.95 W/kg; SAR(10 g) = 2.38 W/kg

Maximum value of SAR (measured) = 16.2 W/kg

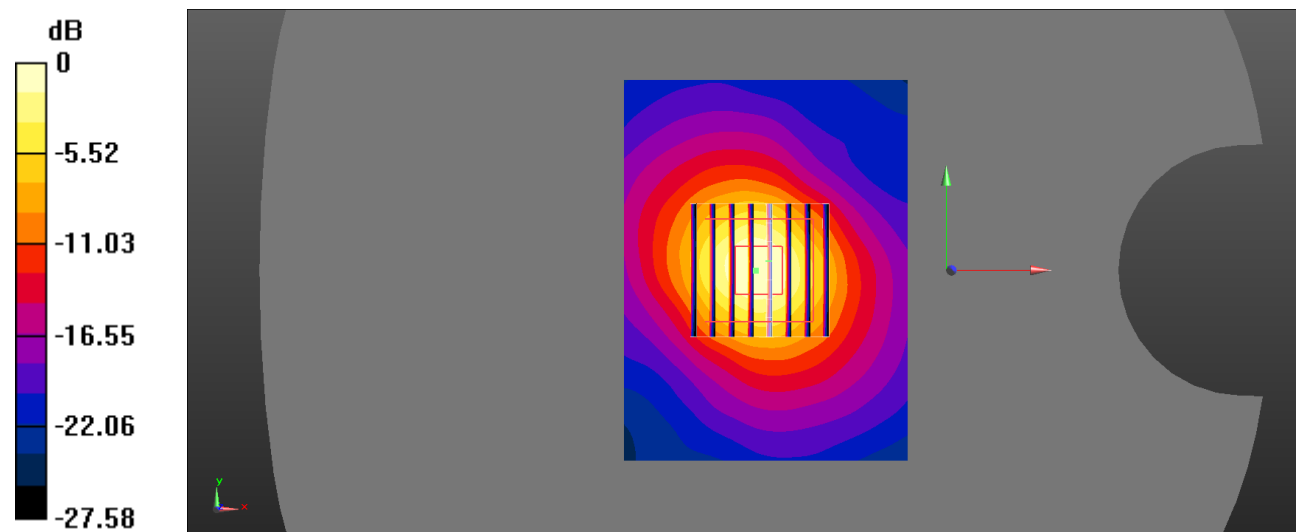

0 dB = 16.2 W/kg = 12.09 dBW/kg

System Performance 5750 MHz Head

DUT: Dipole 5GHz Type: D5GHZV2; Serial: 1374

Communication System: UID 0, CW (0); Frequency: 5750 MHz;Duty Cycle: 1:1
 Medium parameters used: f = 5750 MHz; $\sigma = 5.241$ S/m; $\epsilon_r = 36.223$; $\rho = 1000$ kg/m³
 Phantom section: Flat Section

DASY5 Configuration:

- Probe: EX3DV4 – SN3701; ConvF(4.82, 4.82, 4.82) @ 5750 MHz;
- Sensor-Surface: 2mm (Mechanical Surface Detection)
- Electronics: DAE4 Sn1325; Calibrated: 8/29/2022
- Phantom: SAM-Twin V8.0 P1aP2a; Type: QD 000 P41 AA ; Serial: 1962
- Measurement SW: DASY52, Version 52.10 (2);

Head 5750MHz Pin=100mW/Area Scan (7x9x1): Measurement grid: dx=10mm, dy=10mm

Maximum value of SAR (measured) = 9.07 W/kg

Head 5750MHz Pin=100mW/Zoom Scan (8x8x12)/Cube 0: Measurement grid: dx=4mm, dy=4mm, dz=2mm

Reference Value = 39.16 V/m; Power Drift = 0.12 dB

Peak SAR (extrapolated) = 24.5 W/kg

SAR(1 g) = 8.73 W/kg; SAR(10 g) = 2.47 W/kg

Maximum value of SAR (measured) = 9.39 W/kg

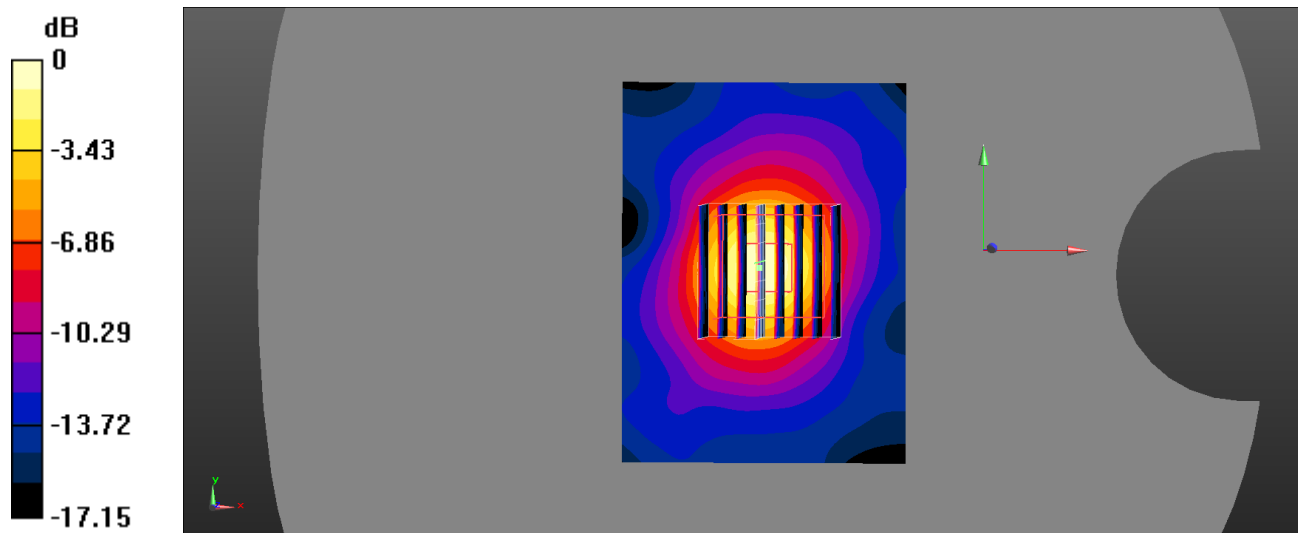

0 dB = 9.39 W/kg = 9.73 dBW/kg

EUT TEST STRATEGY AND METHODOLOGY

Test Positions for Device Operating Next to a Person’s Ear

This category includes most wireless handsets with fixed, retractable or internal antennas located toward the top half of the device, with or without a foldout, sliding or similar keypad cover. The handset should have its earpiece located within the upper ¼ of the device, either along the centerline or off-centered, as perceived by its users. This type of handset should be positioned in a normal operating position with the “test device reference point” located along the “vertical centerline” on the front of the device aligned to the “ear reference point”. The “test device reference point” should be located at the same level as the center of the earpiece region. The “vertical centerline” should bisect the front surface of the handset at its top and bottom edges. A “ear reference point” is located on the outer surface of the head phantom on each ear spacer. It is located 1.5 cm above the center of the ear canal entrance in the “phantom reference plane” defined by the three lines joining the center of each “ear reference point” (left and right) and the tip of the mouth.

A handset should be initially positioned with the earpiece region pressed against the ear spacer of a head phantom. For the SCC-34/SC-2 head phantom, the device should be positioned parallel to the “N-F” line defined along the base of the ear spacer that contains the “ear reference point”. For interim head phantoms, the device should be positioned parallel to the cheek for maximum RF energy coupling. The “test device reference point” is aligned to the “ear reference point” on the head phantom and the “vertical centerline” is aligned to the “phantom reference plane”. This is called the “initial ear position”. While maintaining these three alignments, the body of the handset is gradually adjusted to each of the following positions for evaluating SAR:

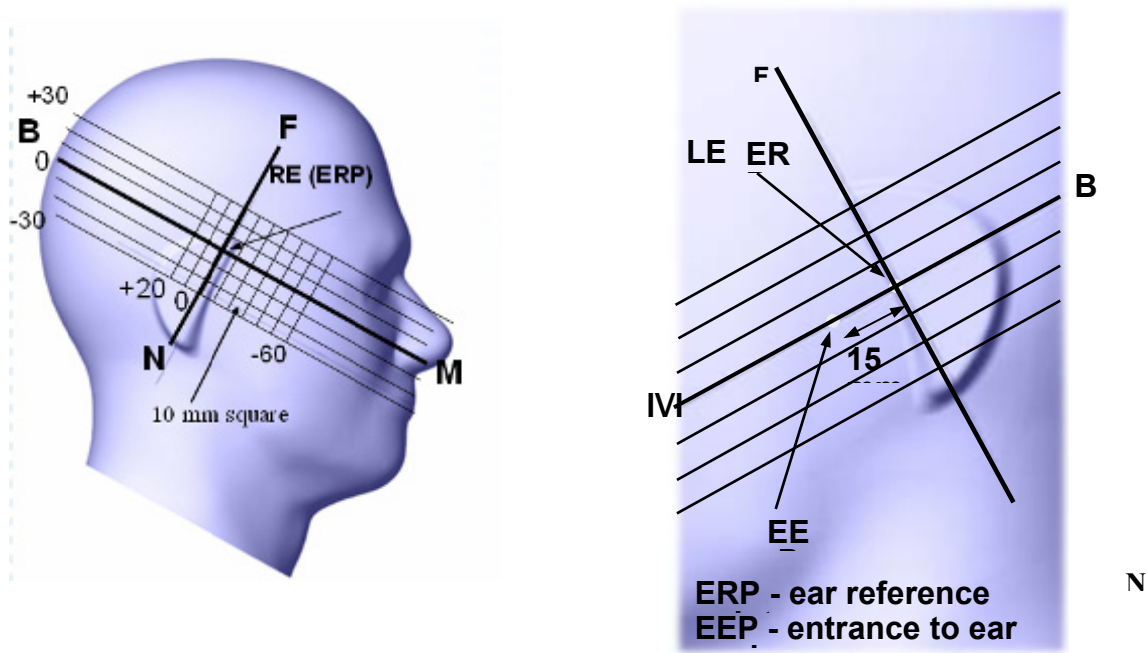

Cheek/Touch Position

The device is brought toward the mouth of the head phantom by pivoting against the “ear reference point” or along the “N-F” line for the SCC-34/SC-2 head phantom.

This test position is established:

- When any point on the display, keypad or mouthpiece portions of the handset is in contact with the phantom.
- (or) When any portion of a foldout, sliding or similar keypad cover opened to its intended self-adjusting normal use position is in contact with the cheek or mouth of the phantom.

For existing head phantoms – when the handset loses contact with the phantom at the pivoting point, rotation should continue until the device touches the cheek of the phantom or breaks its last contact from the ear spacer.

Cheek /Touch Position

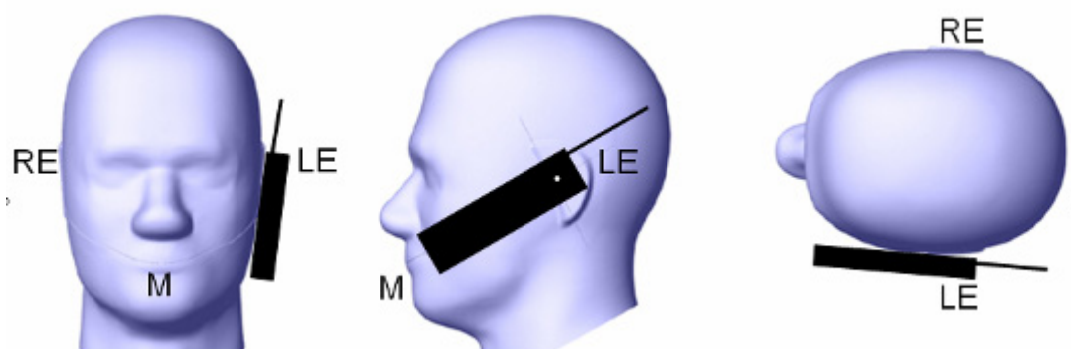

Ear/Tilt Position

With the handset aligned in the “Cheek/Touch Position”:

1) If the earpiece of the handset is not in full contact with the phantom’s ear spacer (in the “Cheek/Touch position”) and the peak SAR location for the “Cheek/Touch” position is located at the ear spacer region or corresponds to the earpiece region of the handset, the device should be returned to the “initial ear position” by rotating it away from the mouth until the earpiece is in full contact with the ear spacer.

2) (otherwise) The handset should be moved (translated) away from the cheek perpendicular to the line passes through both “ear reference points” (note: one of these ear reference points may not physically exist on a split head model) for approximate 2-3 cm. While it is in this position, the device handset is tilted away from the mouth with respect to the “test device reference point” until the inside angle between the vertical centerline on the front surface of the phone and the horizontal line passing through the ear reference point is by 15°. After the tilt, it is then moved (translated) back toward the head perpendicular to the line passes through both “ear reference points” until the device touches the phantom or the ear spacer. If the antenna touches the head first, the positioning process should be repeated with a tilt angle less than 15° so that the device and its antenna would touch the phantom simultaneously. This test position may require a device holder or positioner to achieve the translation and tilting with acceptable positioning repeatability.

If a device is also designed to transmit with its keypad cover closed for operating in the head position, such positions should also be considered in the SAR evaluation. The device should be tested on the left and right side of the head phantom in the “Cheek/Touch” and “Ear/Tilt” positions. When applicable, each configuration should be tested with the antenna in its fully extended and fully retracted positions. These test configurations should be tested at the high, middle and low frequency channels of each operating mode; for example, AMPS, CDMA, and TDMA. If the SAR measured at the middle channel for each test configuration (left, right, Cheek/Touch, Tile/Ear, extended and retracted) is at least 2.0 dB lower than the SAR limit, testing at the high and low channels is optional for such test configuration(s). If the transmission band of the test device is less than 10 MHz, testing at the high and low frequency channels is optional.

Ear /Tilt 15° Position

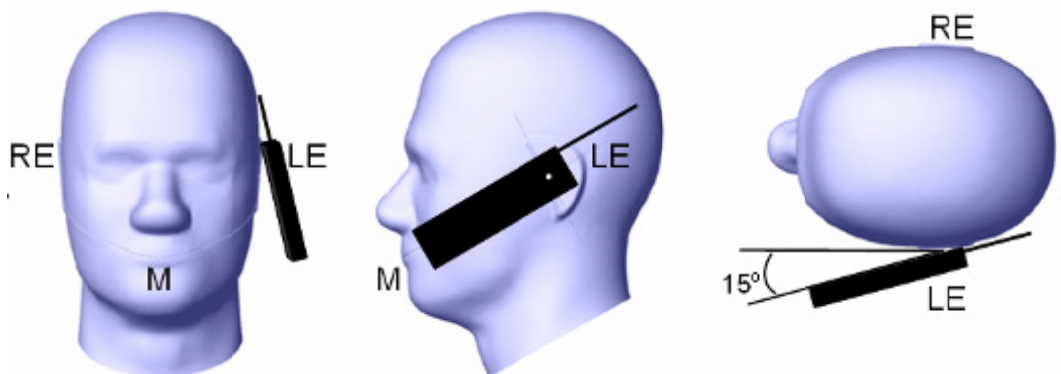

Test positions for body-worn and other configurations

Body-worn operating configurations should be tested with the belt-clips and holsters attached to the device and positioned against a flat phantom in normal use configurations. Devices with a headset output should be tested with a headset connected to the device. When multiple accessories that do not contain metallic components are supplied with the device, the device may be tested with only the accessory that dictates the closest spacing to the body. When multiple accessories that contain metallic components are supplied with the device, the device must be tested with each accessory that contains a unique metallic component. If multiple accessories share an identical metallic component (e.g., the same metallic belt-clip used with different holsters with no other metallic components), only the accessory that dictates the closest spacing to the body must be tested.

Body-worn accessories may not always be supplied or available as options for some devices that are intended to be authorized for body-worn use. A separation distance of 1.5 cm between the back of the device and a flat phantom is recommended for testing body-worn SAR compliance under such circumstances. Other separation distances may be used, but they should not exceed 2.5 cm. In these cases, the device may use body-worn accessories that provide a separation distance greater than that tested for the device provided however that the accessory contains no metallic components.

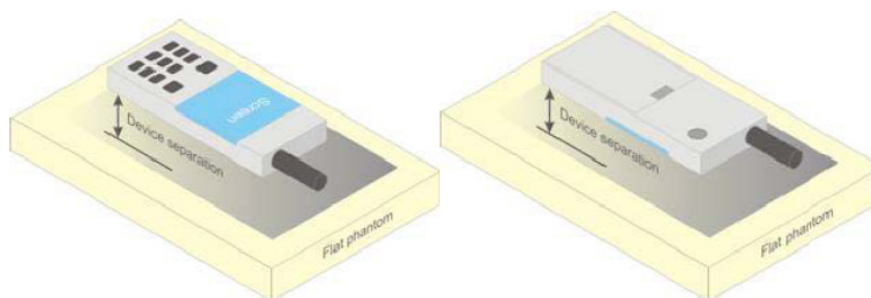

Figure 5 – Test positions for body-worn devices

SAR Evaluation Procedure

The evaluation was performed with the following procedure:

Step 1: Measurement of the SAR value at a fixed location above the ear point or central position was used as a reference value for assessing the power drop. The SAR at this point is measured at the start of the test and then again at the end of the testing.

Step 2: The SAR distribution at the exposed side of the head was measured at a distance of 4 mm from the inner surface of the shell. The area covered the entire dimension of the head or EUT and the horizontal grid spacing was 10 mm x 10 mm. Based on these data, the area of the maximum absorption was determined by spline interpolation. The first Area Scan covers the entire dimension of the EUT to ensure that the hotspot was correctly identified.

Step 3: Around this point, a volume of 30 mm x 30 mm x 30 mm was assessed by measuring 7x 7 x 7 points. On the basis of this data set, the spatial peak SAR value was evaluated under the following procedure:

1) The data at the surface were extrapolated, since the center of the dipoles is 1.2 mm away from the tip of the probe and the distance between the surface and the lowest measuring point is 1.3 mm. The extrapolation was based on a least square algorithm. A polynomial of the fourth order was calculated through the points in z-axes. This polynomial was then used to evaluate the points between the surface and the probe tip.

2) The maximum interpolated value was searched with a straightforward algorithm. Around this maximum the SAR values averaged over the spatial volumes (1 g or 10 g) were computed by the 3D-Spline interpolation algorithm. The 3D-Spline is composed of three one dimensional splines with the "Not a knot"-condition (in x, y and z-directions). The volume was integrated with the trapezoidal-algorithm. One thousand points (10 x 10 x 10) were interpolated to calculate the averages.

All neighboring volumes were evaluated until no neighboring volume with a higher average value was found.

Step 4: Re-measurement of the SAR value at the same location as in Step 1. If the value changed by more than 5%, the evaluation was repeated.

Test methodology

EN50360:2017
EN50566:2017
EN62209-1:2016
EN62209-2:2010
EN50663:2017
EN62479:2010
TGN20

CONDUCTED OUTPUT POWER MEASUREMENT

Test Results:
GSM

Band	Frequency (MHz)	Conducted Output Power	
		(dBm)	(W)
GSM900	880.2	33.89	2.449
	902.0	33.67	2.328
	914.8	33.58	2.280
DCS1800	1710.4	30.13	1.030
	1747.8	30.38	1.091
	1784.6	30.13	1.030

GPRS

Mode	Channel No.	Frequency (MHz)	RF Output Power (dBm)			
			1 slot	2 slots	3 slots	4 slots
GSM900	975	880.2	33.52	33.12	31.04	28.87
	60	902.0	33.14	32.63	30.66	28.38
	124	914.8	33.13	32.56	30.42	28.38
DCS1800	513	1710.4	30.86	28.64	26.78	25.19
	700	1747.8	30.87	28.68	26.85	25.20
	884	1784.6	30.61	28.44	26.67	25.07

For SAR, the time based average power is relevant, the difference in between depends on the duty cycle of the TDMA signal.

Number of Time slot	1	2	3	4
Duty Cycle	1:8	1:4	1:2.66	1:2
Time based Ave. power compared to slotted Ave. power	-9 dB	-6 dB	-4.25 dB	-3 dB
Crest Factor	8	4	2.66	2

The time based average power for GPRS

Mode	Channel No.	Frequency (MHz)	RF Output Power (dBm)			
			1 slot	2 slots	3 slots	4 slots
GSM900	975	880.2	24.52	27.12	26.79	25.87
	60	902.0	24.14	26.63	26.41	25.38
	124	914.8	24.13	26.56	26.17	25.38
DCS1800	513	1710.4	21.86	22.64	22.53	22.19
	700	1747.8	21.87	22.68	22.60	22.20
	884	1784.6	21.61	22.44	22.42	22.07

Note:

1. For GSM voice, 1 timeslot has been activated with power level 5 (900 MHz band) and 0 (1800 MHz band).
2. For GPRS, 1, 2, 3 and 4 timeslots has been activated separately with power control level 3(900 MHz band) and 3(1800 MHz band).

WCDMA Band 1

Test Condition	Test Mode	3GPP Sub Test	Averaged Mean Power (dBm)		
			Low Channel	Mid Channel	High Channel
Normal	Rel 99 RMC	1	22.57	22.46	22.47
	HSDPA	1	20.84	20.61	21.09
		2	20.78	20.58	21.41
		3	21.31	19.97	21.71
		4	21.31	21.30	21.62
	HSUPA	1	20.75	20.66	20.61
		2	20.65	20.57	20.56
		3	20.59	20.42	20.38
		4	20.23	20.55	20.55
		5	20.82	20.58	20.58
	HSPA+	1	21.23	20.93	21.61

WCDMA Band 8

Test Condition	Test Mode	3GPP Sub Test	Averaged Mean Power (dBm)		
			Low Channel	Mid Channel	High Channel
Normal	Rel 99 RMC	1	22.49	22.50	22.61
	HSDPA	1	22.10	22.11	21.73
		2	22.53	22.15	21.58
		3	22.60	22.49	21.04
		4	22.26	22.77	21.36
	HSUPA	1	22.08	22.18	21.66
		2	22.49	22.19	21.80
		3	22.92	22.59	21.48
		4	22.57	22.63	21.32
		5	22.59	22.47	21.48
	HSPA+	1	21.58	21.22	21.58

Note:

The default test configuration is to measure SAR with an established radio link between the EUT and a communication test set using a 12.2 kbps RMC (reference measurement Channel) Configured in Test Loop Mode 1.

LTE Band 1:

Test Band	Test Bandwidth	Test Channel	Resource Block Size	Power(dBm)
Band 1	5 MHz	Low	RB1#0	22.49
			RB8#0	22.43
		Middle	RB1#0	22.37
			RB8#0	22.51
		High	RB1#24	22.00
			RB8#17	22.38
	20 MHz	Low	RB1#0	22.99
			RB18#0	22.70
		Middle	RB1#0	22.91
			RB18#0	22.67
		High	RB1#99	22.86
			RB18#82	22.57

LTE Band 3:

Test Band	Test Bandwidth	Test Channel	Resource Block Size	Power(dBm)
Band 3	1.4 MHz	Low	RB1#0	22.56
			RB5#0	22.75
		Middle	RB1#0	22.68
			RB5#0	21.98
		High	RB1#5	22.65
			RB5#1	22.49
	5 MHz	Low	RB1#0	23.04
			RB8#0	21.98
		Middle	RB1#0	22.01
			RB8#0	21.98
		High	RB1#24	22.58
			RB8#17	22.57
	20 MHz	Low	RB1#0	23.14
			RB18#0	23.05
		Middle	RB1#0	23.26
			RB18#0	22.97
		High	RB1#99	22.86
			RB18#82	22.94

LTE Band 8:

Test Band	Test Bandwidth	Test Channel	Resource Block Size	Power(dBm)
Band 8	1.4 MHz	Low	RB1#0	23.14
			RB5#0	22.96
		Middle	RB1#0	22.98
			RB5#0	22.01
		High	RB1#5	23.08
			RB5#1	22.93
	5 MHz	Low	RB1#0	23.17
			RB8#0	23.08
		Middle	RB1#0	22.83
			RB8#0	21.95
		High	RB1#24	21.98
			RB8#17	23.15
	10 MHz	Low	RB1#0	23.46
			RB12#0	23.32
		Middle	RB1#0	23.20
RB12#0			23.44	
High		RB1#49	23.41	
		RB12#38	23.35	

LTE Band 28:

Test Band	Test Bandwidth	Test Channel	Resource Block Size	Power(dBm)
Band 28	3 MHz	Low	RB1#0	23.08
			RB4#0	22.87
		Middle	RB1#0	22.88
			RB4#0	23.01
		High	RB1#14	23.08
			RB4#11	23.38
	5 MHz	Low	RB1#0	22.88
			RB4#0	22.90
		Middle	RB1#0	21.98
			RB4#0	22.89
		High	RB1#14	21.99
			RB4#11	23.09
	20 MHz	Low	RB1#0	23.45
			RB8#0	23.32
		Middle	RB1#0	23.32
RB8#0			23.50	
High		RB1#24	23.93	
		RB8#17	23.40	

LTE Band 40:

Test Band	Test Bandwidth	Test Channel	Resource Block Size	Power(dBm)
Band 40	5 MHz	Low	RB1#0	21.95
			RB8#0	22.04
		Middle	RB1#0	21.96
			RB8#0	22.37
		High	RB1#24	22.55
			RB8#17	22.60
	20 MHz	Low	RB1#0	22.97
			RB18#0	22.77
		Middle	RB1#0	22.91
			RB18#0	22.88
		High	RB1#99	22.99
			RB18#82	22.99

Note:

1. The CMW500 Wideband Radio Communication tester is used for LTE output power measurements and SAR testing. Closed loop power control is used to keep the radio transmitters the max output power during the test.

Bluetooth:

Mode	Mode	EIRP Power (dBm)	Power (mW)
Hopping	DH1	3.95	2.483
	2DH1	2.14	1.637
	3DH1	2.14	1.637
BLE_1M	Low channel	-4.32	0.370
	Middle channel	-4.92	0.322
	High channel	-4.76	0.334
BLE_2M	Low channel	-4.56	0.350
	Middle channel	-5.61	0.275
	High channel	-5.29	0.296

Note:

1. EN50663-SAR is not required for low-power equipment where the available antenna power and/or the average total radiated power is less than or equal to the Pmax values given in Annex A (20 mW for head and trunk and 40mW for limbs)

Wi-Fi (2.4G Band):

Band	Frequency (MHz)	EIRP Power	
		(dBm)	(mW)
802.11b	2412	14.64	29.107
	2442	15.77	37.757
	2472	16.31	42.756
802.11g	2412	13.50	22.387
	2442	15.20	33.113
	2472	14.86	30.620
802.11n-HT20	2412	12.09	16.181
	2442	14.68	29.376
	2472	15.20	33.113
802.11n-HT40	2422	12.53	17.906
	2442	13.53	22.542
	2462	13.12	20.512

Note:

1. EN50663-SAR is not required for low-power equipment where the available antenna power and/or the average total radiated power is less than or equal to the Pmax values given in Annex A (20 mW for head and trunk and 40mW for limbs).

Wi-Fi (5G Band)

Band	Frequency (MHz)	EIRP Power	
		(dBm)	(mW)
802.11a	5180	11.92	15.560
	5200	11.82	15.205
	5240	11.69	14.757
802.11n-HT20	5180	11.23	13.274
	5200	11.12	12.942
	5240	10.99	12.560
802.11n-HT40	5190	11.82	15.205
	5230	11.68	14.723
802.11ac-VHT20	5180	11.20	13.183
	5200	11.08	12.823
	5240	11.03	12.677
802.11ac-VHT40	5190	11.87	15.382
	5230	11.69	14.757
802.11ac-VHT80	5210	11.16	13.062

Band	Frequency (MHz)	EIRP Power	
		(dBm)	(mW)
802.11a	5745	10.46	11.117
	5785	10.55	11.350
	5825	10.50	11.220
802.11n-HT20	5745	10.40	10.965
	5785	10.44	11.066
	5825	10.46	11.117
802.11n-HT40	5755	10.39	10.940
	5795	10.41	10.990
802.11ac-VHT20	5745	10.39	10.940
	5785	10.46	11.117
	5825	10.45	11.092
802.11ac-VHT40	5755	10.37	10.889
	5795	10.38	10.914
802.11ac-VHT80	5775	10.44	11.066

Note:

EN50663-SAR is not required for low-power equipment where the available antenna power and/or the average total radiated power is less than or equal to the Pmax values given in Annex A (20 mW for head and trunk and 40mW for limbs)

Maximum Target Output Power

Max Target Power(dBm)			
Mode/Band	Channel		
	Low	Middle	High
GSM 900	34.0	34.0	34.0
GPRS 1 TX Slot	34.0	34.0	34.0
GPRS 2 TX Slot	33.5	33.5	33.5
GPRS 3 TX Slot	31.5	31.5	31.5
GPRS 4 TX Slot	29.0	29.0	29.0
DCS 1800	30.5	30.5	30.5
GPRS 1 TX Slot	31.0	31.0	31.0
GPRS 2 TX Slot	29.0	29.0	29.0
GPRS 3 TX Slot	27.0	27.0	27.0
GPRS 4 TX Slot	25.5	25.5	25.5
WCDMA Band 1	23.0	23.0	23.0
WCDMA Band 8	23.5	23.5	23.5
LTE Band 1	23.5	23.5	23.5
LTE Band 3	23.5	23.5	23.5
LTE Band 8	24.0	24.0	24.0
LTE Band 28	24.0	24.0	24.0
LTE Band 40	23.5	23.5	23.5
Bluetooth BDR/EDR	4.0	4.0	4.0
BLE_1M	-4.0	-4.0	-4.0
BLE_2M	-4.5	-4.5	-4.5
WLAN 2.4G	15.0	16.0	16.5
WIFI 5.2G	12.0	12.0	12.0
WIFI 5.8G	11.0	11.0	11.0

SAR MEASUREMENT RESULTS

This page summarizes the results of the performed dosimetric evaluation.

Test Results:

Environmental Conditions:

Temperature:	23.4~24.3°C	22.6~23.4°C	22.6~23.3°C	23.0~24.0°C	23.5~24.4°C
Relative Humidity:	32~43 %	36~47 %	47~58 %	37~47 %	35~45 %
ATM Pressure:	101.3 kPa	101.3 kPa	101.3 kPa	101.3 kPa	101.3 kPa
Test Date:	2023/04/08	2023/04/09	2023/04/10	2023/04/11	2023/04/12

Temperature:	22.3~23.2°C	22.4~23.3°C
Relative Humidity:	38~48 %	33~43 %
ATM Pressure:	101.3 kPa	101.3 kPa
Test Date:	2023/04/18	2023/04/19

* Testing was performed by Luke Jiang and Sid Luo.

GSM 900:

EUT Position	Frequency (MHz)	Test Mode	Max. Meas. Power (dBm)	Max. Rated Power (dBm)	10g SAR (W/Kg)				
					Scaled Factor	Meas.	Scaled SAR	Limit	Plot
Head Left Cheek	880.2	GSM	33.89	34.0	1.026	0.010	0.02	2.0	/
	902.0	GSM	33.67	34.0	1.079	0.015	0.02	2.0	1#
	914.8	GSM	33.58	34.0	1.102	0.011	0.02	2.0	/
Head Left Tilt	880.2	GSM	/	/	/	/	/	2.0	/
	902.0	GSM	33.67	34.0	1.079	0.007	0.01	2.0	/
	914.8	GSM	/	/	/	/	/	2.0	/
Head Right Cheek	880.2	GSM	/	/	/	/	/	2.0	/
	902.0	GSM	33.67	34.0	1.079	0.009	0.01	2.0	/
	914.8	GSM	/	/	/	/	/	2.0	/
Head Right Tilt	880.2	GSM	/	/	/	/	/	2.0	/
	902.0	GSM	33.67	34.0	1.079	0.004	0.01	2.0	/
	914.8	GSM	/	/	/	/	/	2.0	/
Body-Worn-Back (5mm)	880.2	GSM	33.89	34.0	1.026	0.082	0.09	2.0	2#
	902.0	GSM	33.67	34.0	1.079	0.070	0.08	2.0	/
	914.8	GSM	33.58	34.0	1.102	0.067	0.08	2.0	/
Body Front (5mm)	880.2	GPRS	/	/	/	/	/	2.0	/
	902.0	GPRS	32.63	33.5	1.222	0.017	0.03	2.0	/
	914.8	GPRS	/	/	/	/	/	2.0	/
Body Back (5mm)	880.2	GPRS	/	/	/	/	/	2.0	/
	902.0	GPRS	32.63	33.5	1.222	0.058	0.08	2.0	/
	914.8	GPRS	/	/	/	/	/	2.0	/
Limb Front (0mm)	880.2	GPRS	/	/	/	/	/	4.0	/
	902.0	GPRS	32.63	33.5	1.222	0.053	0.07	4.0	/
	914.8	GPRS	/	/	/	/	/	4.0	/
Limb Back (0mm)	880.2	GPRS	33.12	33.5	1.091	0.632	0.69	4.0	3#
	902.0	GPRS	32.63	33.5	1.222	0.455	0.56	4.0	/
	914.8	GPRS	32.56	33.5	1.242	0.381	0.48	4.0	/
Limb Left (0mm)	880.2	GPRS	/	/	/	/	/	4.0	/
	902.0	GPRS	32.63	33.5	1.222	0.029	0.04	4.0	/
	914.8	GPRS	/	/	/	/	/	4.0	/
Limb Right (0mm)	880.2	GPRS	/	/	/	/	/	4.0	/
	902.0	GPRS	32.63	33.5	1.222	0.013	0.02	4.0	/
	914.8	GPRS	/	/	/	/	/	4.0	/
Limb Top (0mm)	880.2	GPRS	/	/	/	/	/	4.0	/
	902.0	GPRS	32.63	33.5	1.222	0.004	0.01	4.0	/
	914.8	GPRS	/	/	/	/	/	4.0	/
Limb Bottom (0mm)	880.2	GPRS	/	/	/	/	/	4.0	/
	902.0	GPRS	32.63	33.5	1.222	0.066	0.09	4.0	/
	914.8	GPRS	/	/	/	/	/	4.0	/

Note:

1. When the 10-g SAR is ≤ 1.0 W/Kg, testing for low and high channel is optional.
2. The EUT is a Class B Smart Phone which can be attached to both GPRS and GSM services, using one service at a time.
3. The Multi-slot has maximum 4 Downlink slots and 4 Uplink slots, the maximum active slots is 5, when perform the multiple slots scan, 3DL+2UL is the worst case.
4. The EUT transmit and receive through the same GSM antenna while testing SAR.

DCS 1800:

EUT Position	Frequency (MHz)	Test Mode	Max. Meas. Power (dBm)	Max. Rated Power (dBm)	10g SAR (W/Kg)				
					Scaled Factor	Meas.	Scaled SAR	Limit	Plot
Head Left Cheek	1710.4	GSM	/	/	/	/	/	2.0	/
	1747.8	GSM	30.38	30.5	1.028	0.321	0.33	2.0	/
	1784.6	GSM	/	/	/	/	/	2.0	/
Head Left Tilt	1710.4	GSM	/	/	/	/	/	2.0	/
	1747.8	GSM	30.38	30.5	1.028	0.352	0.37	2.0	/
	1784.6	GSM	/	/	/	/	/	2.0	/
Head Right Cheek	1710.4	GSM	30.13	30.5	1.089	0.430	0.47	2.0	4#
	1747.8	GSM	30.38	30.5	1.028	0.440	0.46	2.0	/
	1784.6	GSM	30.13	30.5	1.089	0.389	0.43	2.0	/
Head Right Tilt	1710.4	GSM	/	/	/	/	/	2.0	/
	1747.8	GSM	30.38	30.5	1.028	0.307	0.32	2.0	/
	1784.6	GSM	/	/	/	/	/	2.0	/
Body-Worn-Back (5mm)	1710.4	GSM	30.13	30.5	1.089	0.308	0.34	2.0	/
	1747.8	GSM	30.38	30.5	1.028	0.307	0.32	2.0	/
	1784.6	GSM	30.13	30.5	1.089	0.316	0.35	2.0	5#
Body Front (5mm)	1710.4	GPRS	/	/	/	/	/	2.0	/
	1747.8	GPRS	28.68	29.0	1.076	0.166	0.18	2.0	/
	1784.6	GPRS	/	/	/	/	/	2.0	/
Body Back (5mm)	1710.4	GPRS	/	/	/	/	/	2.0	/
	1747.8	GPRS	28.68	29.0	1.076	0.283	0.31	2.0	/
	1784.6	GPRS	/	/	/	/	/	2.0	/
Limb Front (0mm)	1710.4	GPRS	/	/	/	/	/	4.0	/
	1747.8	GPRS	28.68	29.0	1.076	0.504	0.55	4.0	/
	1784.6	GPRS	/	/	/	/	/	4.0	/
Limb Back (0mm)	1710.4	GPRS	28.64	29.0	1.086	0.871	0.95	4.0	/
	1747.8	GPRS	28.68	29.0	1.076	0.926	1.00	4.0	/
	1784.6	GPRS	28.44	29.0	1.138	0.994	1.14	4.0	6#
Limb Left (0mm)	1710.4	GPRS	/	/	/	/	/	4.0	/
	1747.8	GPRS	28.68	29.0	1.076	0.577	0.63	4.0	/
	1784.6	GPRS	/	/	/	/	/	4.0	/
Limb Right (0mm)	1710.4	GPRS	/	/	/	/	/	4.0	/
	1747.8	GPRS	28.68	29.0	1.076	0.092	0.10	4.0	/
	1784.6	GPRS	/	/	/	/	/	4.0	/
Limb Top (0mm)	1710.4	GPRS	/	/	/	/	/	4.0	/
	1747.8	GPRS	28.68	29.0	1.076	0.666	0.72	4.0	/
	1784.6	GPRS	/	/	/	/	/	4.0	/
Limb Bottom (0mm)	1710.4	GPRS	/	/	/	/	/	4.0	/
	1747.8	GPRS	28.68	29.0	1.076	0.026	0.03	4.0	/
	1784.6	GPRS	/	/	/	/	/	4.0	/

Note:

1. When the 10-g SAR is ≤ 1.0 W/Kg, testing for low and high channel is optional.
2. The EUT is a Class B Smart Phone which can be attached to both GPRS and GSM services, using one service at a time.
3. The Multi-slot has maximum 4 Downlink slots and 4 Uplink slots, the maximum active slots is 5, when perform the multiple slots scan, 3DL+2UL is the worst case.
4. The EUT transmit and receive through the same GSM antenna while testing SAR.

WCDMA Band 1

EUT Position	Frequency (MHz)	Test Mode	Max. Meas. Power (dBm)	Max. Rated Power (dBm)	10g SAR (W/Kg)				
					Scaled Factor	Meas.	Scaled SAR	Limit	Plot
Head Left Cheek	1922.6	RMC	/	/	/	/	/	2.0	/
	1950.0	RMC	22.46	23.0	1.132	0.419	0.48	2.0	/
	1977.4	RMC	/	/	/	/	/	2.0	/
Head Left Tilt	1922.6	RMC	/	/	/	/	/	2.0	/
	1950.0	RMC	22.46	23.0	1.132	0.447	0.51	2.0	/
	1977.4	RMC	/	/	/	/	/	2.0	/
Head Right Cheek	1922.6	RMC	22.57	23.0	1.104	0.715	0.79	2.0	7#
	1950.0	RMC	22.46	23.0	1.132	0.527	0.60	2.0	/
	1977.4	RMC	22.47	23.0	1.130	0.568	0.65	2.0	/
Head Right Tilt	1922.6	RMC	/	/	/	/	/	2.0	/
	1950.0	RMC	22.46	23.0	1.132	0.367	0.42	2.0	/
	1977.4	RMC	/	/	/	/	/	2.0	/
Body Front (5mm)	1922.6	RMC	/	/	/	/	/	2.0	/
	1950.0	RMC	22.46	23.0	1.132	0.209	0.24	2.0	/
	1977.4	RMC	/	/	/	/	/	2.0	/
Body Back (5mm)	1922.6	RMC	22.57	23.0	1.104	0.589	0.66	2.0	8#
	1950.0	RMC	22.46	23.0	1.132	0.456	0.52	2.0	/
	1977.4	RMC	22.47	23.0	1.130	0.500	0.57	2.0	/
Limb Front (0mm)	1922.6	RMC	/	/	/	/	/	4.0	/
	1950.0	RMC	22.46	23.0	1.132	0.752	0.86	4.0	/
	1977.4	RMC	/	/	/	/	/	4.0	/
Limb Back (0mm)	1922.6	RMC	22.57	23.0	1.104	1.750	1.94	4.0	9#
	1950.0	RMC	22.46	23.0	1.132	1.430	1.62	4.0	/
	1977.4	RMC	22.47	23.0	1.130	1.490	1.69	4.0	/
Limb Left (0mm)	1922.6	RMC	/	/	/	/	/	4.0	/
	1950.0	RMC	22.46	23.0	1.132	0.697	0.79	4.0	/
	1977.4	RMC	/	/	/	/	/	4.0	/
Limb Right (0mm)	1922.6	RMC	/	/	/	/	/	4.0	/
	1950.0	RMC	22.46	23.0	1.132	0.119	0.14	4.0	/
	1977.4	RMC	/	/	/	/	/	4.0	/
Limb Top (0mm)	1922.6	RMC	/	/	/	/	/	4.0	/
	1950.0	RMC	22.46	23.0	1.132	0.117	0.14	4.0	/
	1977.4	RMC	/	/	/	/	/	4.0	/
Limb Bottom (0mm)	1922.6	RMC	/	/	/	/	/	4.0	/
	1950.0	RMC	22.46	23.0	1.132	0.030	0.04	4.0	/
	1977.4	RMC	/	/	/	/	/	4.0	/

WCDMA Band 8

EUT Position	Frequency (MHz)	Test Mode	Max. Meas. Power (dBm)	Max. Rated Power (dBm)	10g SAR (W/Kg)				
					Scaled Factor	Meas.	Scaled SAR	Limit	Plot
Head Left Cheek	882.6	RMC	22.49	23.5	1.262	0.007	0.01	2.0	/
	897.6	RMC	22.50	23.5	1.259	0.008	0.01	2.0	/
	912.4	RMC	22.61	23.5	1.227	0.011	0.02	2.0	10#
Head Left Tilt	882.6	RMC	/	/	/	/	/	2.0	/
	897.6	RMC	22.50	23.5	1.259	0.003	0.01	2.0	/
	912.4	RMC	/	/	/	/	/	2.0	/
Head Right Cheek	882.6	RMC	/	/	/	/	/	2.0	/
	897.6	RMC	22.50	23.5	1.259	0.005	0.01	2.0	/
	912.4	RMC	/	/	/	/	/	2.0	/
Head Right Tilt	882.6	RMC	/	/	/	/	/	2.0	/
	897.6	RMC	22.50	23.5	1.259	0.002	0.01	2.0	/
	912.4	RMC	/	/	/	/	/	2.0	/
Body Front (5mm)	882.6	RMC	/	/	/	/	/	2.0	/
	897.6	RMC	22.50	23.5	1.259	0.014	0.02	2.0	/
	912.4	RMC	/	/	/	/	/	2.0	/
Body Back (5mm)	882.6	RMC	22.49	23.5	1.262	0.050	0.07	2.0	11#
	897.6	RMC	22.50	23.5	1.259	0.049	0.07	2.0	/
	912.4	RMC	22.61	23.5	1.227	0.038	0.05	2.0	/
Limb Front (0mm)	882.6	RMC	/	/	/	/	/	4.0	/
	897.6	RMC	22.50	23.5	1.259	0.047	0.06	4.0	/
	912.4	RMC	/	/	/	/	/	4.0	/
Limb Back (0mm)	882.6	RMC	22.49	23.5	1.262	0.331	0.42	4.0	/
	897.6	RMC	22.50	23.5	1.259	0.340	0.43	4.0	/
	912.4	RMC	22.61	23.5	1.227	0.346	0.43	4.0	12#
Limb Left (0mm)	882.6	RMC	/	/	/	/	/	4.0	/
	897.6	RMC	22.50	23.5	1.259	0.023	0.03	4.0	/
	912.4	RMC	/	/	/	/	/	4.0	/
Limb Right (0mm)	882.6	RMC	/	/	/	/	/	4.0	/
	897.6	RMC	22.50	23.5	1.259	0.008	0.01	4.0	/
	912.4	RMC	/	/	/	/	/	4.0	/
Limb Top (0mm)	882.6	RMC	/	/	/	/	/	4.0	/
	897.6	RMC	22.50	23.5	1.259	0.002	0.01	4.0	/
	912.4	RMC	/	/	/	/	/	4.0	/
Limb Bottom (0mm)	882.6	RMC	/	/	/	/	/	4.0	/
	897.6	RMC	22.50	23.5	1.259	0.050	0.07	4.0	/
	912.4	RMC	/	/	/	/	/	4.0	/

Note:

1. When the 10-g SAR is $\leq 1.0W/Kg$, testing for low and high channel is optional.
2. The default test configuration is to measure SAR with an established radio link between the EUT and a communication test set using a 12.2 kbps RMC (reference measurement Channel) Configured in Test Loop Mode.

LTE FDD Band 1:

EUT Position	Frequency (MHz)	Modulation Type	Bandwidth (MHz)	RB	Max. Meas. Power (dBm)	Max. Rated Power (dBm)	10g SAR (W/Kg)				
							Scaled Factor	Meas.	Scaled SAR	Limit	Plot
Head Left Cheek	1930	QPSK	20	1	/	/	/	/	/	2.0	/
	1950	QPSK	20	1	22.91	23.5	1.146	0.651	0.75	2.0	/
	1970	QPSK	20	1	/	/	/	/	/	2.0	/
Head Left Tilt	1930	QPSK	20	1	/	/	/	/	/	2.0	/
	1950	QPSK	20	1	22.91	23.5	1.146	0.707	0.81	2.0	/
	1970	QPSK	20	1	/	/	/	/	/	2.0	/
Head Right Cheek	1930	QPSK	20	1	22.99	23.5	1.125	0.765	0.87	2.0	/
	1950	QPSK	20	1	22.91	23.5	1.146	0.940	1.08	2.0	13#
	1970	QPSK	20	1	22.86	23.5	1.159	0.725	0.85	2.0	/
	1950	QPSK	20	50%	22.91	23.5	1.146	0.696	0.80	2.0	/
	1950	QPSK	20	100%	22.91	23.5	1.146	0.678	0.78	2.0	/
Head Right Tilt	1930	QPSK	20	1	/	/	/	/	/	2.0	/
	1950	QPSK	20	1	22.91	23.5	1.146	0.658	0.76	2.0	/
	1970	QPSK	20	1	/	/	/	/	/	2.0	/
Body Front (5mm)	1930	QPSK	20	1	/	/	/	/	/	2.0	/
	1950	QPSK	20	1	22.91	23.5	1.146	0.319	0.37	2.0	/
	1970	QPSK	20	1	/	/	/	/	/	2.0	/
Body Back (5mm)	1930	QPSK	20	1	22.99	23.5	1.125	0.643	0.73	2.0	/
	1950	QPSK	20	1	22.91	23.5	1.146	0.482	0.56	2.0	/
	1970	QPSK	20	1	22.86	23.5	1.159	0.635	0.74	2.0	14#
	1930	QPSK	20	50%	22.99	23.5	1.125	0.553	0.63	2.0	/
	1930	QPSK	20	100%	22.99	23.5	1.125	0.546	0.62	2.0	/

EUT Position	Frequency (MHz)	Modulation Type	Bandwidth (MHz)	RB	Max. Meas. Power (dBm)	Max. Rated Power (dBm)	10g SAR (W/Kg)				
							Scaled Factor	Meas.	Scaled SAR	Limit	Plot
Limb Front (0mm)	1930	QPSK	20	1	/	/	/	/	/	4.0	/
	1950	QPSK	20	1	22.91	23.5	1.146	1.130	1.30	4.0	/
	1970	QPSK	20	1	/	/	/	/	/	4.0	/
Limb Back (0mm)	1930	QPSK	20	1	22.99	23.5	1.125	2.070	2.33	4.0	15#
	1950	QPSK	20	1	22.91	23.5	1.146	1.920	2.20	4.0	/
	1970	QPSK	20	1	22.86	23.5	1.159	1.930	2.24	4.0	/
	1930	QPSK	20	50%	22.99	23.5	1.125	1.620	1.83	4.0	/
	1930	QPSK	20	100%	22.99	23.5	1.125	1.630	1.84	4.0	/
Limb Left (0mm)	1930	QPSK	20	1	/	/	/	/	/	4.0	/
	1950	QPSK	20	1	22.91	23.5	1.146	1.020	1.17	4.0	/
	1970	QPSK	20	1	/	/	/	/	/	4.0	/
Limb Right (0mm)	1930	QPSK	20	1	/	/	/	/	/	4.0	/
	1950	QPSK	20	1	22.91	23.5	1.146	0.182	0.21	4.0	/
	1970	QPSK	20	1	/	/	/	/	/	4.0	/
Limb Top (0mm)	1930	QPSK	20	1	/	/	/	/	/	4.0	/
	1950	QPSK	20	1	22.91	23.5	1.146	1.380	1.59	4.0	/
	1970	QPSK	20	1	/	/	/	/	/	4.0	/
Limb Bottom (0mm)	1930	QPSK	20	1	/	/	/	/	/	4.0	/
	1950	QPSK	20	1	22.91	23.5	1.146	0.044	0.06	4.0	/
	1970	QPSK	20	1	/	/	/	/	/	4.0	/

LTE FDD Band 3:

EUT Position	Frequency (MHz)	Modulation Type	Bandwidth (MHz)	RB	Max. Meas. Power (dBm)	Max. Rated Power (dBm)	10g SAR (W/Kg)				
							Scaled Factor	Meas.	Scaled SAR	Limit	Plot
Head Left Cheek	1720	QPSK	20	1	/	/	/	/	/	2.0	/
	1747.5	QPSK	20	1	23.26	23.5	1.057	0.664	0.71	2.0	/
	1775	QPSK	20	1	/	/	/	/	/	2.0	/
Head Left Tilt	1720	QPSK	20	1	/	/	/	/	/	2.0	/
	1747.5	QPSK	20	1	23.26	23.5	1.057	0.698	0.74	2.0	/
	1775	QPSK	20	1	/	/	/	/	/	2.0	/
Head Right Cheek	1720	QPSK	20	1	23.14	23.5	1.086	0.644	0.70	2.0	/
	1747.5	QPSK	20	1	23.26	23.5	1.057	0.957	1.02	2.0	16#
	1775	QPSK	20	1	22.94	23.5	1.138	0.651	0.75	2.0	/
	1747.5	QPSK	20	50%	23.26	23.5	1.057	0.561	0.60	2.0	/
	1747.5	QPSK	20	100%	23.26	23.5	1.057	0.576	0.61	2.0	/
Head Right Tilt	1720	QPSK	20	1	/	/	/	/	/	2.0	/
	1747.5	QPSK	20	1	23.26	23.5	1.057	0.556	0.59	2.0	/
	1775	QPSK	20	1	/	/	/	/	/	2.0	/
Body Front (5mm)	1720	QPSK	20	1	/	/	/	/	/	2.0	/
	1747.5	QPSK	20	1	23.26	23.5	1.057	0.074	0.08	2.0	/
	1775	QPSK	20	1	/	/	/	/	/	2.0	/
Body Back (5mm)	1720	QPSK	20	1	23.14	23.5	1.086	0.545	0.60	2.0	/
	1747.5	QPSK	20	1	23.26	23.5	1.057	0.587	0.63	2.0	/
	1775	QPSK	20	1	22.94	23.5	1.138	0.622	0.71	2.0	17#
	1775	QPSK	20	50%	22.94	23.5	1.138	0.500	0.57	2.0	/
	1775	QPSK	20	100%	22.94	23.5	1.138	0.495	0.57	2.0	/

EUT Position	Frequency (MHz)	Modulation Type	Bandwidth (MHz)	RB	Max. Meas. Power (dBm)	Max. Rated Power (dBm)	10g SAR (W/Kg)				
							Scaled Factor	Meas.	Scaled SAR	Limit	Plot
Limb Front (0mm)	1720	QPSK	20	1	/	/	/	/	/	4.0	/
	1747.5	QPSK	20	1	23.26	23.5	1.057	1.220	1.29	4.0	/
	1775	QPSK	20	1	/	/	/	/	/	4.0	/
Limb Back (0mm)	1720	QPSK	20	1	23.14	23.5	1.086	2.180	2.37	4.0	/
	1747.5	QPSK	20	1	23.26	23.5	1.057	2.270	2.40	4.0	/
	1775	QPSK	20	1	22.94	23.5	1.138	2.250	2.56	4.0	18#
	1747.5	QPSK	20	50%	23.26	23.5	1.057	1.820	1.93	4.0	/
	1747.5	QPSK	20	100%	23.26	23.5	1.057	1.840	1.95	4.0	/
Limb Left (0mm)	1720	QPSK	20	1	/	/	/	/	/	4.0	/
	1747.5	QPSK	20	1	23.26	23.5	1.057	1.210	1.28	4.0	/
	1775	QPSK	20	1	/	/	/	/	/	4.0	/
Limb Right (0mm)	1720	QPSK	20	1	/	/	/	/	/	4.0	/
	1747.5	QPSK	20	1	23.26	23.5	1.057	0.199	0.22	4.0	/
	1775	QPSK	20	1	/	/	/	/	/	4.0	/
Limb Top (0mm)	1720	QPSK	20	1	/	/	/	/	/	4.0	/
	1747.5	QPSK	20	1	23.26	23.5	1.057	1.250	1.33	4.0	/
	1775	QPSK	20	1	/	/	/	/	/	4.0	/
Limb Bottom (0mm)	1720	QPSK	20	1	/	/	/	/	/	4.0	/
	1747.5	QPSK	20	1	23.26	23.5	1.057	0.051	0.06	4.0	/
	1775	QPSK	20	1	/	/	/	/	/	4.0	/

LTE FDD Band 8:

EUT Position	Frequency (MHz)	Modulation Type	Bandwidth (MHz)	RB	Max. Meas. Power (dBm)	Max. Rated Power (dBm)	10g SAR (W/Kg)				
							Scaled Factor	Meas.	Scaled SAR	Limit	Plot
Head Left Cheek	885	QPSK	10	1	23.46	24.0	1.132	0.006	0.01	2.0	/
	897.5	QPSK	10	1	23.44	24.0	1.138	0.006	0.01	2.0	/
	910	QPSK	10	1	23.41	24.0	1.146	0.008	0.01	2.0	19#
	910	QPSK	10	50%	23.41	24.0	1.146	0.006	0.01	2.0	/
	910	QPSK	10	100%	23.41	24.0	1.146	0.007	0.01	2.0	/
Head Left Tilt	885	QPSK	10	1	/	/	/	/	/	2.0	/
	897.5	QPSK	10	1	23.44	24.0	1.138	0.003	0.01	2.0	/
	910	QPSK	10	1	/	/	/	/	/	2.0	/
Head Right Cheek	885	QPSK	10	1	/	/	/	/	/	2.0	/
	897.5	QPSK	10	1	23.44	24.0	1.138	0.004	0.01	2.0	/
	910	QPSK	10	1	/	/	/	/	/	2.0	/
Head Right Tilt	885	QPSK	10	1	/	/	/	/	/	2.0	/
	897.5	QPSK	10	1	23.44	24.0	1.138	0.003	0.01	2.0	/
	910	QPSK	10	1	/	/	/	/	/	2.0	/
Body Front (5mm)	885	QPSK	10	1	/	/	/	/	/	2.0	/
	897.5	QPSK	10	1	23.44	24.0	1.138	0.015	0.02	2.0	/
	910	QPSK	10	1	/	/	/	/	/	2.0	/
Body Back (5mm)	885	QPSK	10	1	23.46	24.0	1.132	0.055	0.07	2.0	/
	897.5	QPSK	10	1	23.44	24.0	1.138	0.056	0.07	2.0	/
	910	QPSK	10	1	23.41	24.0	1.146	0.057	0.07	2.0	20#
	910	QPSK	10	50%	23.41	24.0	1.146	0.047	0.06	2.0	/
	910	QPSK	10	100%	23.41	24.0	1.146	0.047	0.06	2.0	/

EUT Position	Frequency (MHz)	Modulation Type	Bandwidth (MHz)	RB	Max. Meas. Power (dBm)	Max. Rated Power (dBm)	10g SAR (W/Kg)				
							Scaled Factor	Meas.	Scaled SAR	Limit	Plot
Limb Front (0mm)	885	QPSK	10	1	/	/	/	/	/	4.0	/
	897.5	QPSK	10	1	23.44	24.0	1.138	0.054	0.07	4.0	/
	910	QPSK	10	1	/	/	/	/	/	4.0	/
Limb Back (0mm)	885	QPSK	10	1	23.46	24.0	1.132	0.376	0.43	4.0	/
	897.5	QPSK	10	1	23.44	24.0	1.138	0.390	0.45	4.0	/
	910	QPSK	10	1	23.41	24.0	1.146	0.403	0.47	4.0	21#
	910	QPSK	10	50%	23.41	24.0	1.146	0.291	0.34	4.0	/
	910	QPSK	10	100%	23.41	24.0	1.146	0.294	0.34	4.0	/
Limb Left (0mm)	885	QPSK	10	1	/	/	/	/	/	4.0	/
	897.5	QPSK	10	1	23.44	24.0	1.138	0.027	0.04	4.0	/
	910	QPSK	10	1	/	/	/	/	/	4.0	/
Limb Right (0mm)	885	QPSK	10	1	/	/	/	/	/	4.0	/
	897.5	QPSK	10	1	23.44	24.0	1.138	0.008	0.01	4.0	/
	910	QPSK	10	1	/	/	/	/	/	4.0	/
Limb Top (0mm)	885	QPSK	10	1	/	/	/	/	/	4.0	/
	897.5	QPSK	10	1	23.44	24.0	1.138	0.002	0.01	4.0	/
	910	QPSK	10	1	/	/	/	/	/	4.0	/
Limb Bottom (0mm)	885	QPSK	10	1	/	/	/	/	/	4.0	/
	897.5	QPSK	10	1	23.44	24.0	1.138	0.062	0.08	4.0	/
	910	QPSK	10	1	/	/	/	/	/	4.0	/

LTE FDD Band 28:

EUT Position	Frequency (MHz)	Modulation Type	Bandwidth (MHz)	RB	Max. Meas. Power (dBm)	Max. Rated Power (dBm)	10g SAR (W/Kg)				
							Scaled Factor	Meas.	Scaled SAR	Limit	Plot
Head Left Cheek	713	QPSK	20	1	/	/	/	/	/	2.0	/
	728	QPSK	20	1	23.50	24.0	1.122	0.059	0.07	2.0	/
	738	QPSK	20	1	/	/	/	/	/	2.0	/
Head Left Tilt	713	QPSK	20	1	/	/	/	/	/	2.0	/
	728	QPSK	20	1	23.50	24.0	1.122	0.044	0.05	2.0	/
	738	QPSK	20	1	/	/	/	/	/	2.0	/
Head Right Cheek	713	QPSK	20	1	23.45	24.0	1.135	0.035	0.04	2.0	/
	728	QPSK	20	1	23.50	24.0	1.122	0.063	0.08	2.0	22#
	738	QPSK	20	1	23.93	24.0	1.016	0.053	0.06	2.0	/
	728	QPSK	20	50%	23.50	24.0	1.122	0.055	0.07	2.0	/
	728	QPSK	20	100%	23.50	24.0	1.122	0.057	0.07	2.0	/
Head Right Tilt	713	QPSK	20	1	/	/	/	/	/	2.0	/
	728	QPSK	20	1	23.50	24.0	1.122	0.046	0.06	2.0	/
	738	QPSK	20	1	/	/	/	/	/	2.0	/
Body Front (5mm)	713	QPSK	20	1	/	/	/	/	/	2.0	/
	728	QPSK	20	1	23.50	24.0	1.122	0.087	0.10	2.0	/
	738	QPSK	20	1	/	/	/	/	/	2.0	/
Body Back (5mm)	713	QPSK	20	1	23.45	24.0	1.135	0.137	0.16	2.0	/
	728	QPSK	20	1	23.50	24.0	1.122	0.186	0.21	2.0	/
	738	QPSK	20	1	23.93	24.0	1.016	0.217	0.23	2.0	23#
	738	QPSK	20	50%	23.93	24.0	1.016	0.171	0.18	2.0	/
	738	QPSK	20	100%	23.93	24.0	1.016	0.178	0.19	2.0	/

EUT Position	Frequency (MHz)	Modulation Type	Bandwidth (MHz)	RB	Max. Meas. Power (dBm)	Max. Rated Power (dBm)	10g SAR (W/Kg)				
							Scaled Factor	Meas.	Scaled SAR	Limit	Plot
Limb Front (0mm)	713	QPSK	20	1	/	/	/	/	/	4.0	/
	728	QPSK	20	1	23.50	24.0	1.122	0.260	0.30	4.0	/
	738	QPSK	20	1	/	/	/	/	/	4.0	/
Limb Back (0mm)	713	QPSK	20	1	23.45	24.0	1.135	0.907	1.03	4.0	24#
	728	QPSK	20	1	23.50	24.0	1.122	0.842	0.95	4.0	/
	738	QPSK	20	1	23.93	24.0	1.016	0.733	0.75	4.0	/
	713	QPSK	20	50%	23.45	24.0	1.135	0.621	0.71	4.0	/
	713	QPSK	20	100%	23.45	24.0	1.135	0.632	0.72	4.0	/
Limb Left (0mm)	713	QPSK	20	1	/	/	/	/	/	4.0	/
	728	QPSK	20	1	23.50	24.0	1.122	0.100	0.12	4.0	/
	738	QPSK	20	1	/	/	/	/	/	4.0	/
Limb Right (0mm)	713	QPSK	20	1	/	/	/	/	/	4.0	/
	728	QPSK	20	1	23.50	24.0	1.122	0.162	0.19	4.0	/
	738	QPSK	20	1	/	/	/	/	/	4.0	/
Limb Top (0mm)	713	QPSK	20	1	/	/	/	/	/	4.0	/
	728	QPSK	20	1	23.50	24.0	1.122	0.011	0.02	4.0	/
	738	QPSK	20	1	/	/	/	/	/	4.0	/
Limb Bottom (0mm)	713	QPSK	20	1	/	/	/	/	/	4.0	/
	728	QPSK	20	1	23.50	24.0	1.122	0.214	0.25	4.0	/
	738	QPSK	20	1	/	/	/	/	/	4.0	/

LTE TDD Band 40:

EUT Position	Frequency (MHz)	Modulation Type	Bandwidth (MHz)	RB	Max. Meas. Power (dBm)	Max. Rated Power (dBm)	10g SAR (W/Kg)				
							Scaled Factor	Meas.	Scaled SAR	Limit	Plot
Head Left Cheek	2310	QPSK	20	1	22.97	23.5	1.130	0.045	0.06	2.0	/
	2350	QPSK	20	1	22.91	23.5	1.146	0.039	0.05	2.0	/
	2390	QPSK	20	1	22.99	23.5	1.125	0.058	0.07	2.0	25#
	2390	QPSK	20	50%	22.99	23.5	1.125	0.049	0.06	2.0	/
	2390	QPSK	20	100%	22.99	23.5	1.125	0.053	0.06	2.0	/
Head Left Tilt	2310	QPSK	20	1	/	/	/	/	/	2.0	/
	2350	QPSK	20	1	22.91	23.5	1.146	0.012	0.02	2.0	/
	2390	QPSK	20	1	/	/	/	/	/	2.0	/
Head Right Cheek	2310	QPSK	20	1	/	/	/	/	/	2.0	/
	2350	QPSK	20	1	22.91	23.5	1.146	0.029	0.04	2.0	/
	2390	QPSK	20	1	/	/	/	/	/	2.0	/
Head Right Tilt	2310	QPSK	20	1	/	/	/	/	/	2.0	/
	2350	QPSK	20	1	22.91	23.5	1.146	0.021	0.03	2.0	/
	2390	QPSK	20	1	/	/	/	/	/	2.0	/
Body Front (5mm)	2310	QPSK	20	1	/	/	/	/	/	2.0	/
	2350	QPSK	20	1	22.91	23.5	1.146	0.029	0.04	2.0	/
	2390	QPSK	20	1	/	/	/	/	/	2.0	/
Body Back (5mm)	2310	QPSK	20	1	22.97	23.5	1.130	0.137	0.16	2.0	/
	2350	QPSK	20	1	22.91	23.5	1.146	0.167	0.20	2.0	/
	2390	QPSK	20	1	22.99	23.5	1.125	0.175	0.20	2.0	26#
	2390	QPSK	20	50%	22.99	23.5	1.125	0.167	0.19	2.0	/
	2390	QPSK	20	100%	22.99	23.5	1.125	0.142	0.16	2.0	/

EUT Position	Frequency (MHz)	Modulation Type	Bandwidth (MHz)	RB	Max. Meas. Power (dBm)	Max. Rated Power (dBm)	10g SAR (W/Kg)				
							Scaled Factor	Meas.	Scaled SAR	Limit	Plot
Limb Front (0mm)	2310	QPSK	20	1	/	/	/	/	/	4.0	/
	2350	QPSK	20	1	22.91	23.5	1.146	0.503	0.58	4.0	/
	2390	QPSK	20	1	/	/	/	/	/	4.0	/
Limb Back (0mm)	2310	QPSK	20	1	22.97	23.5	1.130	1.180	1.34	4.0	/
	2350	QPSK	20	1	22.91	23.5	1.146	1.290	1.48	4.0	/
	2390	QPSK	20	1	22.99	23.5	1.125	1.410	1.59	4.0	27#
	2390	QPSK	20	50%	22.99	23.5	1.125	1.110	1.25	4.0	/
	2390	QPSK	20	100%	22.99	23.5	1.125	1.120	1.26	4.0	/
Limb Left (0mm)	2310	QPSK	20	1	/	/	/	/	/	4.0	/
	2350	QPSK	20	1	22.91	23.5	1.146	0.415	0.48	4.0	/
	2390	QPSK	20	1	/	/	/	/	/	4.0	/
Limb Right (0mm)	2310	QPSK	20	1	/	/	/	/	/	4.0	/
	2350	QPSK	20	1	22.91	23.5	1.146	0.046	0.06	4.0	/
	2390	QPSK	20	1	/	/	/	/	/	4.0	/
Limb Top (0mm)	2310	QPSK	20	1	/	/	/	/	/	4.0	/
	2350	QPSK	20	1	22.91	23.5	1.146	0.014	0.02	4.0	/
	2390	QPSK	20	1	/	/	/	/	/	4.0	/
Limb Bottom (0mm)	2310	QPSK	20	1	/	/	/	/	/	4.0	/
	2350	QPSK	20	1	22.91	23.5	1.146	0.170	0.20	4.0	/
	2390	QPSK	20	1	/	/	/	/	/	4.0	/

Note:

1. When the 10-g SAR is $\leq 1.0W/Kg$, testing for low and high channel is optional.
2. The CMW500 Wideband Radio Communication tester is used for LTE output power measurements and SAR testing. Closed loop power control is used to keep the radio transmitters the max output power during the test.
3. All SAR datas are tested start with the **largest channel bandwidth** and measure SAR for QPSK with 1 RB allocation. According to the worst case, SARdatas for QPSK with 50% and 100% RB allocation are tested.

WLAN (2.4G)

EUT Position	Frequency (MHz)	Test Mode	Max. Meas. Power (dBm)	Max. Rated Power (dBm)	10g SAR (W/Kg)				
					Scaled Factor	Meas.	Scaled SAR	Limit	Plot
Head Left Cheek	2412	802.11b	14.64	15.0	1.086	0.294	0.32	2.0	/
	2442	802.11b	15.77	16.0	1.054	0.461	0.49	2.0	/
	2472	802.11b	16.31	16.5	1.045	0.711	0.75	2.0	28#
Head Left Tilt	2412	802.11b	/	/	/	/	/	2.0	/
	2442	802.11b	/	/	/	/	/	2.0	/
	2472	802.11b	16.31	16.5	1.045	0.369	0.39	2.0	/
Head Right Cheek	2412	802.11b	/	/	/	/	/	2.0	/
	2442	802.11b	/	/	/	/	/	2.0	/
	2472	802.11b	16.31	16.5	1.045	0.141	0.15	2.0	/
Head Right Tilt	2412	802.11b	/	/	/	/	/	2.0	/
	2442	802.11b	/	/	/	/	/	2.0	/
	2472	802.11b	16.31	16.5	1.045	0.155	0.17	2.0	/
Body Front (5mm)	2412	802.11b	/	/	/	/	/	2.0	/
	2442	802.11b	/	/	/	/	/	2.0	/
	2472	802.11b	16.31	16.5	1.045	0.225	0.24	2.0	/
Body Back (5mm)	2412	802.11b	14.64	15.0	1.086	0.258	0.29	2.0	/
	2442	802.11b	15.77	16.0	1.054	0.383	0.41	2.0	/
	2472	802.11b	16.31	16.5	1.045	0.406	0.43	2.0	29#
Limb Front (0mm)	2412	802.11b	/	/	/	/	/	4.0	/
	2442	802.11b	/	/	/	/	/	4.0	/
	2472	802.11b	16.31	16.5	1.045	0.874	0.92	4.0	/
Limb Back (0mm)	2412	802.11b	14.64	15.0	1.086	1.020	1.11	4.0	/
	2442	802.11b	15.77	16.0	1.054	1.160	1.23	4.0	30#
	2472	802.11b	16.31	16.5	1.045	0.994	1.04	4.0	/
Limb Left (0mm)	2412	802.11b	/	/	/	/	/	4.0	/
	2442	802.11b	/	/	/	/	/	4.0	/
	2472	802.11b	16.31	16.5	1.045	0.111	0.12	4.0	/
Limb Right (0mm)	2412	802.11b	/	/	/	/	/	4.0	/
	2442	802.11b	/	/	/	/	/	4.0	/
	2472	802.11b	16.31	16.5	1.045	0.407	0.43	4.0	/
Limb Top (0mm)	2412	802.11b	/	/	/	/	/	4.0	/
	2442	802.11b	/	/	/	/	/	4.0	/
	2472	802.11b	16.31	16.5	1.045	0.718	0.76	4.0	/
Limb Bottom (0mm)	2412	802.11b	/	/	/	/	/	4.0	/
	2442	802.11b	/	/	/	/	/	4.0	/
	2472	802.11b	16.31	16.5	1.045	0.023	0.03	4.0	/

Note:

1. When the 10-g SAR is $\leq 1.0W/Kg$, testing for low and high channel is optional.
2. Since 802.11 b mode is the largest power mode of 802.11b/g/n HT20/ n HT40, 802.11b mode is selected to test.

WLAN (5.2G)

EUT Position	Frequency (MHz)	Test Mode	Max. Meas. Power (dBm)	Max. Rated Power (dBm)	10g SAR (W/Kg)				
					Scaled Factor	Meas.	Scaled SAR	Limit	Plot
Head Left Cheek	5180	802.11a	/	/	/	/	/	2.0	/
	5200	802.11a	11.82	12.0	1.042	0.076	0.08	2.0	/
	5240	802.11a	/	/	/	/	/	2.0	/
Head Left Tilt	5180	802.11a	11.92	12.0	1.019	0.081	0.09	2.0	31#
	5200	802.11a	11.82	12.0	1.042	0.080	0.09	2.0	/
	5240	802.11a	11.69	12.0	1.074	0.079	0.09	2.0	/
Head Right Cheek	5180	802.11a	/	/	/	/	/	2.0	/
	5200	802.11a	11.82	12.0	1.042	0.066	0.07	2.0	/
	5240	802.11a	/	/	/	/	/	2.0	/
Head Right Tilt	5180	802.11a	/	/	/	/	/	2.0	/
	5200	802.11a	11.82	12.0	1.042	0.078	0.09	2.0	/
	5240	802.11a	/	/	/	/	/	2.0	/
Body Front (5mm)	5180	802.11a	/	/	/	/	/	2.0	/
	5200	802.11a	11.82	12.0	1.042	0.051	0.06	2.0	/
	5240	802.11a	/	/	/	/	/	2.0	/
Body Back (5mm)	5180	802.11a	11.92	12.0	1.019	0.043	0.05	2.0	/
	5200	802.11a	11.82	12.0	1.042	0.070	0.08	2.0	32#
	5240	802.11a	11.69	12.0	1.074	0.050	0.06	2.0	/
Limb Front (0mm)	5180	802.11a	/	/	/	/	/	4.0	/
	5200	802.11a	11.82	12.0	1.042	0.124	0.13	4.0	/
	5240	802.11a	/	/	/	/	/	4.0	/
Limb Back (0mm)	5180	802.11a	11.92	12.0	1.019	0.145	0.15	4.0	/
	5200	802.11a	11.82	12.0	1.042	0.165	0.18	4.0	33#
	5240	802.11a	11.69	12.0	1.074	0.141	0.16	4.0	/
Limb Left (0mm)	5180	802.11a	/	/	/	/	/	4.0	/
	5200	802.11a	11.82	12.0	1.042	0.016	0.02	4.0	/
	5240	802.11a	/	/	/	/	/	4.0	/
Limb Right (0mm)	5180	802.11a	/	/	/	/	/	4.0	/
	5200	802.11a	11.82	12.0	1.042	0.078	0.09	4.0	/
	5240	802.11a	/	/	/	/	/	4.0	/
Limb Top (0mm)	5180	802.11a	/	/	/	/	/	4.0	/
	5200	802.11a	11.82	12.0	1.042	0.102	0.11	4.0	/
	5240	802.11a	/	/	/	/	/	4.0	/
Limb Bottom (0mm)	5180	802.11a	/	/	/	/	/	4.0	/
	5200	802.11a	11.82	12.0	1.042	0.003	0.01	4.0	/
	5240	802.11a	/	/	/	/	/	4.0	/

Note:

1. When the 10-g SAR is $\leq 1.0W/Kg$, testing for low and high channel is optional.
2. Since 802.11a mode is the largest power mode of 802.11a/ n HT20/ n HT 40/ ac-VHT20/ ac-VHT40/ ac-VHT80, 802.11a mode is selected to test.

WLAN (5.8G)

EUT Position	Frequency (MHz)	Test Mode	Max. Meas. Power (dBm)	Max. Rated Power (dBm)	10g SAR (W/Kg)				
					Scaled Factor	Meas.	Scaled SAR	Limit	Plot
Head Left Cheek	5745	802.11a	/	/	/	/	/	2.0	/
	5785	802.11a	10.55	11.0	1.109	0.172	0.20	2.0	/
	5825	802.11a	/	/	/	/	/	2.0	/
Head Left Tilt	5745	802.11a	/	/	/	/	/	2.0	/
	5785	802.11a	10.55	11.0	1.109	0.184	0.21	2.0	/
	5825	802.11a	/	/	/	/	/	2.0	/
Head Right Cheek	5745	802.11a	/	/	/	/	/	2.0	/
	5785	802.11a	10.55	11.0	1.109	0.157	0.18	2.0	/
	5825	802.11a	/	/	/	/	/	2.0	/
Head Right Tilt	5745	802.11a	10.46	11.0	1.132	0.247	0.28	2.0	34#
	5785	802.11a	10.55	11.0	1.109	0.238	0.27	2.0	/
	5825	802.11a	10.50	11.0	1.122	0.115	0.13	2.0	/
Body Front (5mm)	5745	802.11a	/	/	/	/	/	2.0	/
	5785	802.11a	10.55	11.0	1.109	0.130	0.15	2.0	/
	5825	802.11a	/	/	/	/	/	2.0	/
Body Back (5mm)	5745	802.11a	10.46	11.0	1.132	0.174	0.20	2.0	/
	5785	802.11a	10.55	11.0	1.109	0.187	0.21	2.0	35#
	5825	802.11a	10.50	11.0	1.122	0.155	0.18	2.0	/
Limb Front (0mm)	5745	802.11a	/	/	/	/	/	4.0	/
	5785	802.11a	10.55	11.0	1.109	0.194	0.22	4.0	/
	5825	802.11a	/	/	/	/	/	4.0	/
Limb Back (0mm)	5745	802.11a	10.46	11.0	1.132	0.227	0.26	4.0	/
	5785	802.11a	10.55	11.0	1.109	0.258	0.29	4.0	36#
	5825	802.11a	10.50	11.0	1.122	0.221	0.25	4.0	/
Limb Left (0mm)	5745	802.11a	/	/	/	/	/	4.0	/
	5785	802.11a	10.55	11.0	1.109	0.025	0.03	4.0	/
	5825	802.11a	/	/	/	/	/	4.0	/
Limb Right (0mm)	5745	802.11a	/	/	/	/	/	4.0	/
	5785	802.11a	10.55	11.0	1.109	0.178	0.20	4.0	/
	5825	802.11a	/	/	/	/	/	4.0	/
Limb Top (0mm)	5745	802.11a	/	/	/	/	/	4.0	/
	5785	802.11a	10.55	11.0	1.109	0.160	0.18	4.0	/
	5825	802.11a	/	/	/	/	/	4.0	/
Limb Bottom (0mm)	5745	802.11a	/	/	/	/	/	4.0	/
	5785	802.11a	10.55	11.0	1.109	0.005	0.01	4.0	/
	5825	802.11a	/	/	/	/	/	4.0	/

Note:

1. When the 10-g SAR is $\leq 1.0W/Kg$, testing for mid and high channel is optional.
2. Since 802.11a mode is the largest power mode of 802.11a/ n HT20/ n HT 40/ ac-VHT20/ ac-VHT40/ ac-VHT80, 802.11a mode is selected to test.

Simultaneous Transmission evaluation:

Test Position	Simultaneous Transmitting	P _{avg} (dB m)	P _{avg} (m W)	Main Ant SAR(w/kg)	Distance (mm)	P _{th,m} (mW)	P _{available} (mW)	Exclusion
Head	Bluetooth + Main	4	2.51	1.08	0	20	9.2	Yes
Body	Bluetooth + Main	4	2.51	0.74	5	32	20.16	Yes
Limb	Bluetooth + Main	4	2.51	2.56	0	40	14.4	Yes

Simultaneous Transmission evaluation Detail:

Mode(SAR1+SAR2)	Position	Reported SAR(W/kg)		ΣSAR <2.0W/kg(Head&Body) ΣSAR <4.0W/kg(Limb)
		SAR1	SAR2	
WWAN(GSM/WCDMA/LTE)+ Wi-Fi	Head	1.08	0.75	1.83
WWAN(GSM/WCDMA/LTE)+ Wi-Fi	Body	0.74	0.43	1.17
WWAN(GSM/WCDMA/LTE)+ Wi-Fi	Limb	2.56	1.23	3.79

Note:

1. Wi-Fi 2.4G&5GHz Band and Bluetooth share the same antenna and cannot transmit simultaneously.
2. GSM/WCDMA/LTE share the same antenna and cannot transmit simultaneously.
3. According to EN 62209-2 Annex K, the threshold power level available to the secondary transmitter (P_{available}) is to calculate it from the measured peak spatial-average SAR of the primary transmitter (SAR₁) according to the equation: P_{available}=P_{th,m} × (SAR_{lim} - SAR₁)/SAR_{lim}. If the output power of the secondary transmitter is less than P_{available}, SAR measurement for the secondary transmitter is not necessary.
4. The **Test exclusion Threshold** P_{th,m} is calculated follow the EN 62479 Annex B
5. The **Test exclusion Threshold** formula distance range is 0 - 25mm, so 25mm is used when distance is larger than 25mm.

$$P_{max}' = \exp \left[A s + B s^2 + C \ln(BW) + D \right]$$

Note: s represents the nearest separation distance between the wireless device and the user's body

For compliance with the SAR limit of SAR_{max} = 2 W/kg averaged over m = 10 g in ICNIRP Guidelines [1] and IEEE Std C95.1-2005 [3], use Equations (B.2) to (B.5) in Equation (B.1):

$$A = (-0.4588f^3 + 4.407f^2 - 6.112f + 2.497) / 100 \tag{B.2}$$

$$B = (0.1160f^3 - 1.402f^2 + 3.504f - 0.4367) / 1000 \tag{B.3}$$

$$C = (-0.1333f^3 + 11.89f^2 - 110.8f + 301.4) / 1000 \tag{B.4}$$

$$D = -0.03540f^3 + 0.5023f^2 - 2.297f + 6.104 \tag{B.5}$$

For other values of SAR_{max} using an averaging mass of m = 10 g, multiply the final P_{max}' value by SAR_{max} / 2 W/kg.

Simultaneous Transmission Conclusion

The above numerical summed SAR results for all the case simultaneous transmission conditions were below the SAR limit. Therefore, the above analysis is sufficient to determine that simultaneous transmission cases will not exceed the SAR limit and therefore no measured volumetric simultaneous SAR summation is required.

SAR Plots (Summary of the Highest SAR Values)

Test Plot 1#

DUT: Smart phone; Type: G3 Mecha; Serial: 23N2_1

Communication System: UID 0, Generic GSM (0); Frequency: 902 MHz;Duty Cycle: 1:8

Medium parameters used: $f = 902 \text{ MHz}$; $\sigma = 0.946 \text{ S/m}$; $\epsilon_r = 41.964$; $\rho = 1000 \text{ kg/m}^3$

Phantom section: Left Section

DASY5 Configuration:

- Probe: EX3DV4 - SN3701; ConvF(9.25, 9.25, 9.25) @ 902 MHz;
- Sensor-Surface: 4mm (Mechanical Surface Detection)
- Electronics: DAE4 Sn1325; Calibrated: 8/29/2022
- Phantom: SAM-Twin V8.0 P1aP2a; Type: QD 000 P41 AA ; Serial: 1962
- Measurement SW: DASY52, Version 52.10 (2);

Head Left Cheek/GSM 900 Mid/Area Scan (8x10x1): Measurement grid: dx=15mm, dy=15mm

Maximum value of SAR (measured) = 0.0145 W/kg

Head Left Cheek/GSM 900 Mid/Zoom Scan (5x5x7)/Cube 0: Measurement grid: dx=8mm, dy=8mm, dz=5mm

Reference Value = 0.7320 V/m; Power Drift = -0.04 dB

Peak SAR (extrapolated) = 0.0170 W/kg

SAR(1 g) = 0.023 W/kg; SAR(10 g) = 0.015 W/kg

Maximum value of SAR (measured) = 0.0153 W/kg

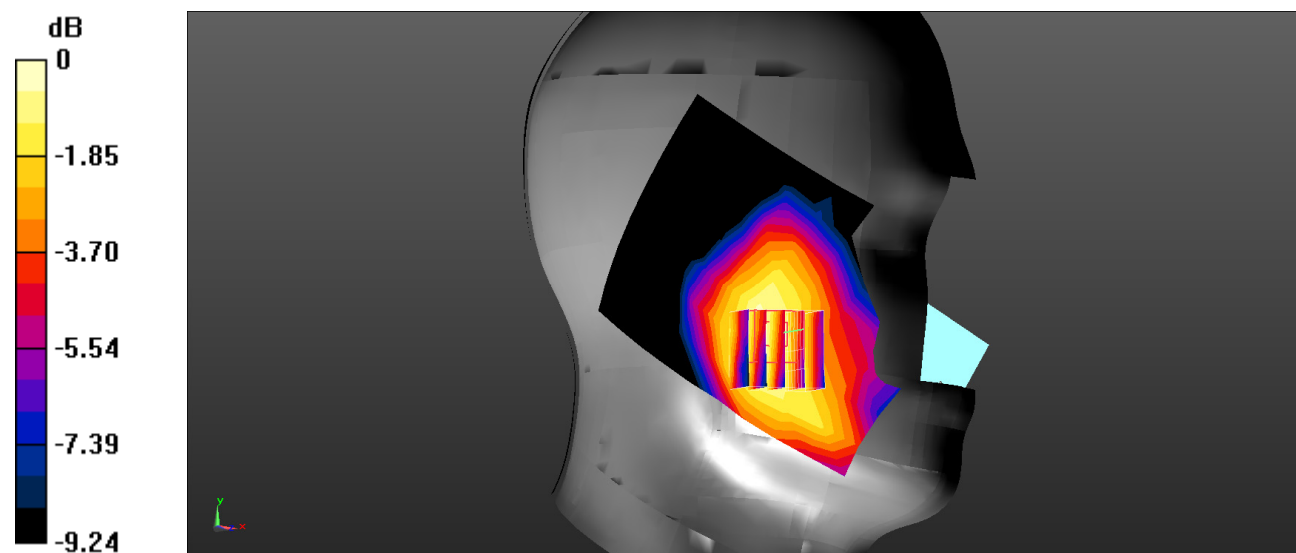

0 dB = 0.0153 W/kg = -18.15 dBW/kg

Test Plot 2#

DUT: Smart phone; Type: G3 Mecha; Serial: 23N2_1

Communication System: UID 0, Generic GSM (0); Frequency: 880.2 MHz;Duty Cycle: 1:8

Medium parameters used: $f = 880.2 \text{ MHz}$; $\sigma = 0.934 \text{ S/m}$; $\epsilon_r = 42.231$; $\rho = 1000 \text{ kg/m}^3$

Phantom section: Flat Section

DASY5 Configuration:

- Probe: EX3DV4 - SN3701; ConvF(9.25, 9.25, 9.25) @ 880.2 MHz;
- Sensor-Surface: 4mm (Mechanical Surface Detection)
- Electronics: DAE4 Sn1325; Calibrated: 8/29/2022
- Phantom: SAM-Twin V8.0 P1aP2a; Type: QD 000 P41 AA ; Serial: 1962
- Measurement SW: DASY52, Version 52.10 (2);

Body Worn Back/GSM 900 Low/Area Scan (8x10x1): Measurement grid: dx=15mm, dy=15mm

Maximum value of SAR (measured) = 0.138 W/kg

Body Worn Back/GSM 900 Low/Zoom Scan (5x5x7)/Cube 0: Measurement grid: dx=8mm, dy=8mm, dz=5mm

Reference Value = 6.442 V/m; Power Drift = -0.18 dB

Peak SAR (extrapolated) = 0.290 W/kg

SAR(1 g) = 0.154 W/kg; SAR(10 g) = 0.082 W/kg

Maximum value of SAR (measured) = 0.161 W/kg

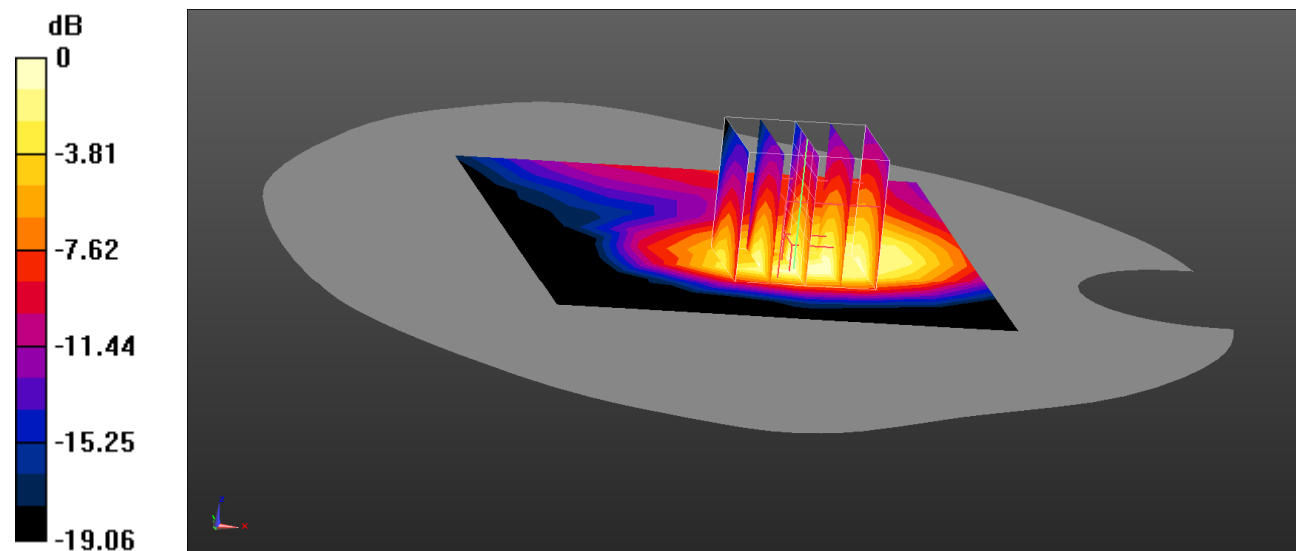

0 dB = 0.161 W/kg = -7.93 dBW/kg

Test Plot 3#

DUT: Smart phone; Type: G3 Mecha; Serial: 23N2_1

Communication System: UID 0, Generic GPRS-2 slots (0); Frequency: 880.2 MHz;Duty Cycle: 1:4

Medium parameters used: $f = 880.2 \text{ MHz}$; $\sigma = 0.934 \text{ S/m}$; $\epsilon_r = 42.231$; $\rho = 1000 \text{ kg/m}^3$

Phantom section: Flat Section

DASY5 Configuration:

- Probe: EX3DV4 - SN3701; ConvF(9.25, 9.25, 9.25) @ 880.2 MHz;
- Sensor-Surface: 4mm (Mechanical Surface Detection)
- Electronics: DAE4 Sn1325; Calibrated: 8/29/2022
- Phantom: SAM-Twin V8.0 P1aP2a; Type: QD 000 P41 AA ; Serial: 1962
- Measurement SW: DASY52, Version 52.10 (2);

Limb Back/GSM 900 Low/Area Scan (8x10x1): Measurement grid: $dx=15\text{mm}$, $dy=15\text{mm}$

Maximum value of SAR (measured) = 0.864 W/kg

Limb Back/GSM 900 Low/Zoom Scan (5x5x7)/Cube 0: Measurement grid: $dx=8\text{mm}$, $dy=8\text{mm}$, $dz=5\text{mm}$

Reference Value = 24.25 V/m; Power Drift = -0.06 dB

Peak SAR (extrapolated) = 2.62 W/kg

SAR(1 g) = 1.29 W/kg; SAR(10 g) = 0.632 W/kg

Maximum value of SAR (measured) = 1.54 W/kg

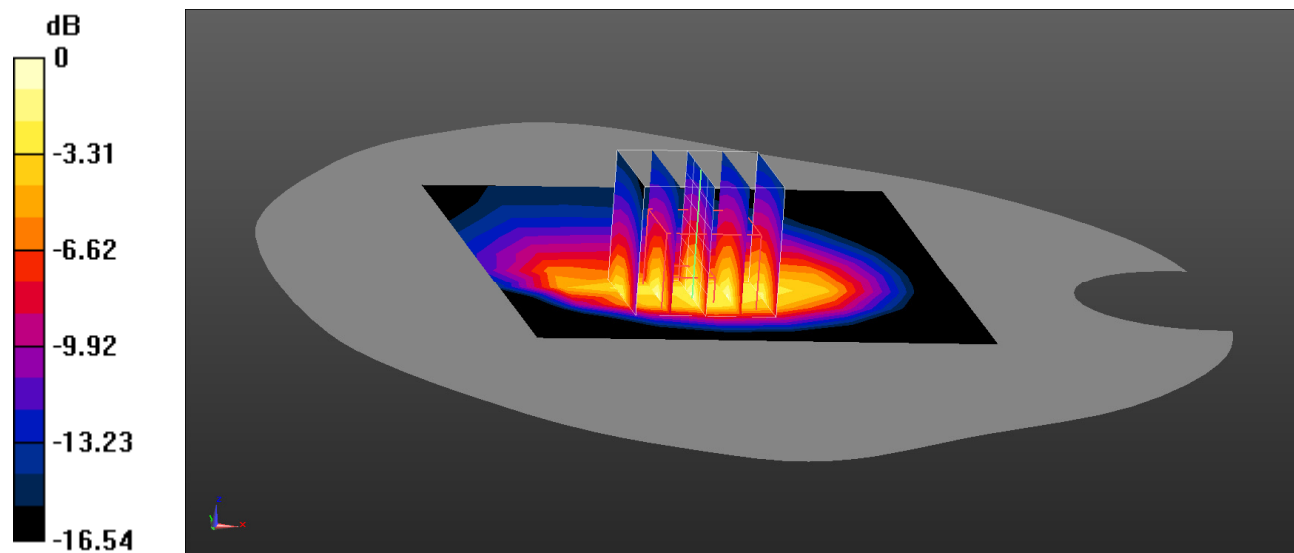

0 dB = 1.54 W/kg = 1.88 dBW/kg

Test Plot 4#

DUT: Smart phone; Type: G3 Mecha; Serial: 23N2_1

Communication System: UID 0, Generic GSM (0); Frequency: 1710.4 MHz;Duty Cycle: 1:8

Medium parameters used: $f = 1710.4 \text{ MHz}$; $\sigma = 1.38 \text{ S/m}$; $\epsilon_r = 41.247$; $\rho = 1000 \text{ kg/m}^3$

Phantom section: Right Section

DASY5 Configuration:

- Probe: EX3DV4 - SN3701; ConvF(7.97, 7.97, 7.97) @ 1710.4 MHz;
- Sensor-Surface: 4mm (Mechanical Surface Detection)
- Electronics: DAE4 Sn1325; Calibrated: 8/29/2022
- Phantom: SAM-Twin V8.0 P1aP2a; Type: QD 000 P41 AA ; Serial: 1962
- Measurement SW: DASY52, Version 52.10 (2);

Head Right Cheek/GSM 1800 Low/Area Scan (8x10x1): Measurement grid: dx=15mm, dy=15mm

Maximum value of SAR (measured) = 0.743 W/kg

Head Right Cheek/GSM 1800 Low/Zoom Scan (5x5x7)/Cube 0: Measurement grid: dx=8mm, dy=8mm, dz=5mm

Reference Value = 14.93 V/m; Power Drift = 0.13 dB

Peak SAR (extrapolated) = 1.34 W/kg

SAR(1 g) = 0.753 W/kg; SAR(10 g) = 0.430 W/kg

Maximum value of SAR (measured) = 0.822 W/kg

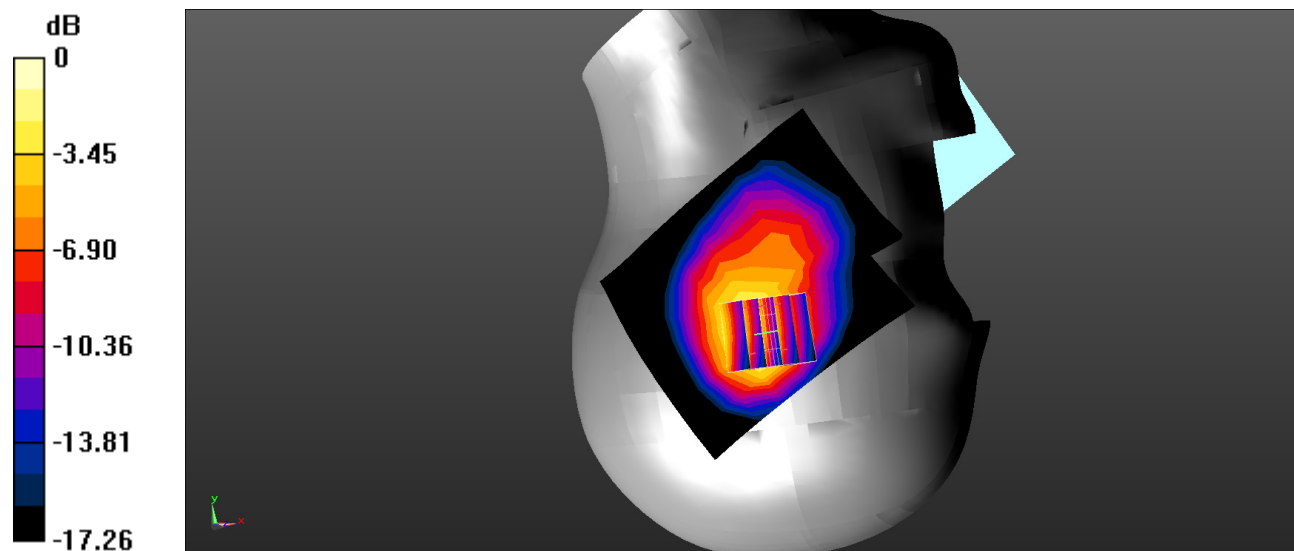

0 dB = 0.822 W/kg = -0.85 dBW/kg

Test Plot 5#

DUT: Smart phone; Type: G3 Mecha; Serial: 23N2_1

Communication System: UID 0, Generic GSM (0); Frequency: 1784.6 MHz;Duty Cycle: 1:8

Medium parameters used: $f = 1784.6 \text{ MHz}$; $\sigma = 1.416 \text{ S/m}$; $\epsilon_r = 40.839$; $\rho = 1000 \text{ kg/m}^3$

Phantom section: Flat Section

DASY5 Configuration:

- Probe: EX3DV4 - SN3701; ConvF(7.97, 7.97, 7.97) @ 1784.6 MHz;
- Sensor-Surface: 4mm (Mechanical Surface Detection)
- Electronics: DAE4 Sn1325; Calibrated: 8/29/2022
- Phantom: SAM-Twin V8.0 P1aP2a; Type: QD 000 P41 AA ; Serial: 1962
- Measurement SW: DASY52, Version 52.10 (2);

Body Worn Back/GSM 1800 High/Area Scan (8x10x1): Measurement grid: dx=15mm, dy=15mm

Maximum value of SAR (measured) = 0.657 W/kg

Body Worn Back/GSM 1800 High/Zoom Scan (5x5x7)/Cube 0: Measurement grid: dx=8mm, dy=8mm, dz=5mm

Reference Value = 18.51 V/m; Power Drift = -0.02 dB

Peak SAR (extrapolated) = 1.14 W/kg

SAR(1 g) = 0.581 W/kg; SAR(10 g) = 0.316 W/kg

Maximum value of SAR (measured) = 0.612 W/kg

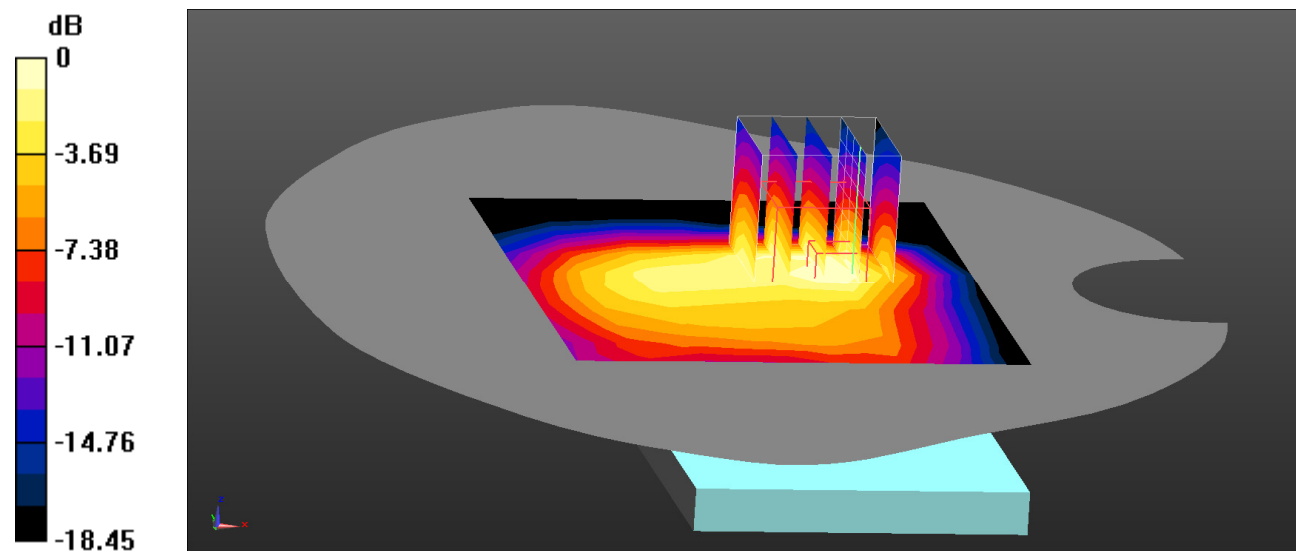

0 dB = 0.612 W/kg = -2.13 dBW/kg

Test Plot 6#

DUT: Smart phone; Type: G3 Mecha; Serial: 23N2_1

Communication System: UID 0, Generic GPRS-2 slots (0); Frequency: 1784.6 MHz;Duty Cycle: 1:4

Medium parameters used: $f = 1784.6 \text{ MHz}$; $\sigma = 1.416 \text{ S/m}$; $\epsilon_r = 40.839$; $\rho = 1000 \text{ kg/m}^3$

Phantom section: Flat Section

DASY5 Configuration:

- Probe: EX3DV4 - SN3701; ConvF(7.97, 7.97, 7.97) @ 1784.6 MHz;
- Sensor-Surface: 4mm (Mechanical Surface Detection)
- Electronics: DAE4 Sn1325; Calibrated: 8/29/2022
- Phantom: SAM-Twin V8.0 P1aP2a; Type: QD 000 P41 AA ; Serial: 1962
- Measurement SW: DASY52, Version 52.10 (2);

Limb Back/GSM 1800 High/Area Scan (8x10x1): Measurement grid: dx=15mm, dy=15mm

Maximum value of SAR (measured) = 2.12 W/kg

Limb Back/GSM 1800 High/Zoom Scan (5x5x7)/Cube 0: Measurement grid: dx=8mm, dy=8mm, dz=5mm

Reference Value = 22.38 V/m; Power Drift = 0.07 dB

Peak SAR (extrapolated) = 4.64 W/kg

SAR(1 g) = 1.96 W/kg; SAR(10 g) = 0.994 W/kg

Maximum value of SAR (measured) = 2.23 W/kg

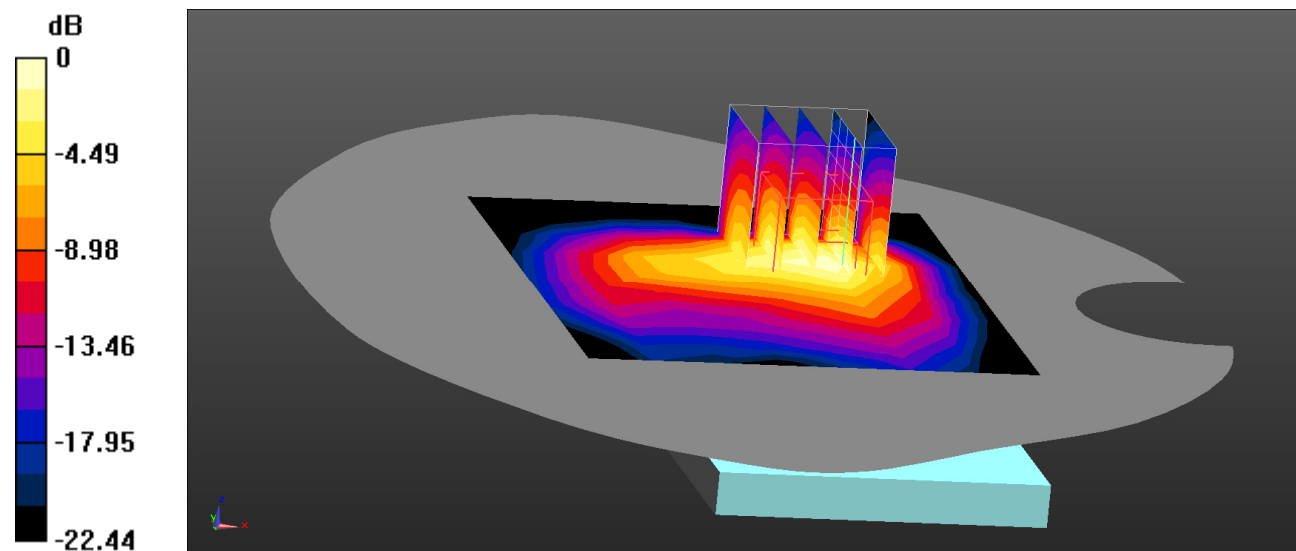

0 dB = 2.23 W/kg = 3.48 dBW/kg

Test Plot 7#

DUT: Smart phone; Type: G3 Mecha; Serial:23N2_1

Communication System: UID 0, WCDMA (0); Frequency: 1922.6 MHz;Duty Cycle: 1:1

Medium parameters used: $f = 1922.6 \text{ MHz}$; $\sigma = 1.38 \text{ S/m}$; $\epsilon_r = 40.71$; $\rho = 1000 \text{ kg/m}^3$

Phantom section: Right Section

DASY5 Configuration:

- Probe: EX3DV4 - SN3701; ConvF(7.65, 7.65, 7.65) @ 1922.6 MHz;
- Sensor-Surface: 4mm (Mechanical Surface Detection)
- Electronics: DAE4 Sn1325; Calibrated: 8/29/2022
- Phantom: SAM-Twin V8.0 P1aP2a; Type: QD 000 P41 AA ; Serial: 1962
- Measurement SW: DASY52, Version 52.10 (2);

Head Right Cheek/WCDMA Band 1 Low/Area Scan (8x10x1): Measurement grid: dx=15mm, dy=15mm

Maximum value of SAR (measured) = 1.26 W/kg

Head Right Cheek/WCDMA Band 1 Low/Zoom Scan (5x5x7)/Cube 0: Measurement grid: dx=8mm, dy=8mm, dz=5mm

Reference Value = 21.51 V/m; Power Drift = 0.01 dB

Peak SAR (extrapolated) = 2.25 W/kg

SAR(1 g) = 1.28 W/kg; SAR(10 g) = 0.715 W/kg

Maximum value of SAR (measured) = 1.39 W/kg

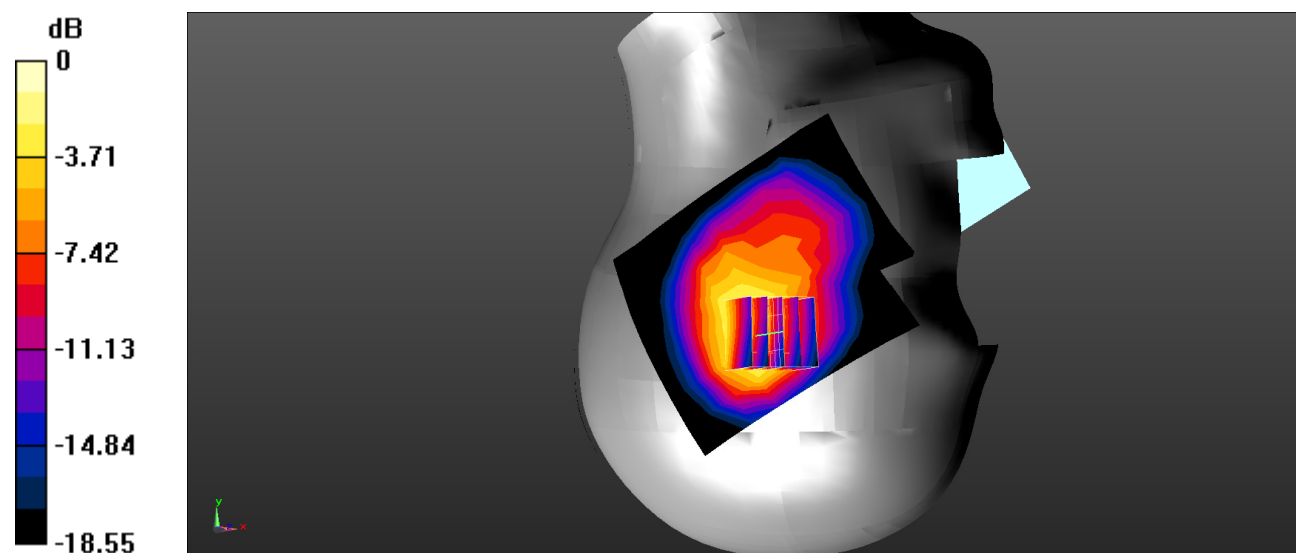

0 dB = 1.39 W/kg = 1.43 dBW/kg

Test Plot 8#**DUT: Smart phone; Type: G3 Mecha; Serial: 23N2_1**

Communication System: UID 0, WCDMA (0); Frequency: 1922.6 MHz; Duty Cycle: 1:1

Medium parameters used: $f = 1922.6$ MHz; $\sigma = 1.38$ S/m; $\epsilon_r = 40.71$; $\rho = 1000$ kg/m³

Phantom section: Flat Section

DASY5 Configuration:

- Probe: EX3DV4 - SN3701; ConvF(7.65, 7.65, 7.65) @ 1922.6 MHz;
- Sensor-Surface: 4mm (Mechanical Surface Detection)
- Electronics: DAE4 Sn1325; Calibrated: 8/29/2022
- Phantom: SAM-Twin V8.0 P1aP2a; Type: QD 000 P41 AA ; Serial: 1962
- Measurement SW: DASY52, Version 52.10 (2);

Body Back/WCDMA Band 1 Low/Area Scan (8x10x1): Measurement grid: dx=15mm, dy=15mm

Maximum value of SAR (measured) = 1.24 W/kg

Body Back/WCDMA Band 1 Low/Zoom Scan (5x5x7)/Cube 0: Measurement grid: dx=8mm, dy=8mm, dz=5mm

Reference Value = 23.69 V/m; Power Drift = 0.02 dB

Peak SAR (extrapolated) = 2.17 W/kg

SAR(1 g) = 1.12 W/kg; SAR(10 g) = 0.589 W/kg

Maximum value of SAR (measured) = 1.20 W/kg

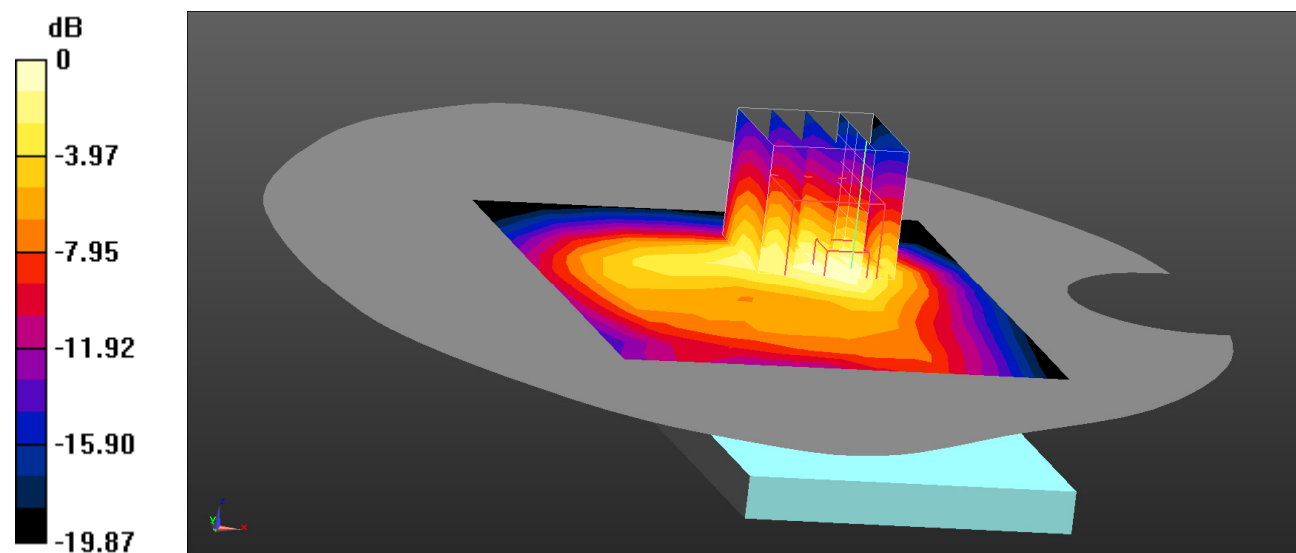

0 dB = 1.20 W/kg = 0.79 dBW/kg

Test Plot 9#

DUT: Smart phone; Type: G3 Mecha; Serial: 23N2_1

Communication System: UID 0, WCDMA (0); Frequency: 1922.6 MHz;Duty Cycle: 1:1

Medium parameters used: $f = 1922.6 \text{ MHz}$; $\sigma = 1.38 \text{ S/m}$; $\epsilon_r = 40.71$; $\rho = 1000 \text{ kg/m}^3$

Phantom section: Flat Section

DASY5 Configuration:

- Probe: EX3DV4 - SN3701; ConvF(7.65, 7.65, 7.65) @ 1922.6 MHz;
- Sensor-Surface: 4mm (Mechanical Surface Detection)
- Electronics: DAE4 Sn1325; Calibrated: 8/29/2022
- Phantom: SAM-Twin V8.0 P1aP2a; Type: QD 000 P41 AA ; Serial: 1962
- Measurement SW: DASY52, Version 52.10 (2);

Limb Back/WCDMA Band 1 Low/Area Scan (8x10x1): Measurement grid: dx=15mm, dy=15mm

Maximum value of SAR (measured) = 3.80 W/kg

Limb Back/WCDMA Band 1 Low/Zoom Scan (5x5x7)/Cube 0: Measurement grid: dx=8mm, dy=8mm, dz=5mm

Reference Value = 26.64 V/m; Power Drift = 0.04 dB

Peak SAR (extrapolated) = 8.37 W/kg

SAR(1 g) = 3.54 W/kg; SAR(10 g) = 1.75 W/kg

Maximum value of SAR (measured) = 3.99 W/kg

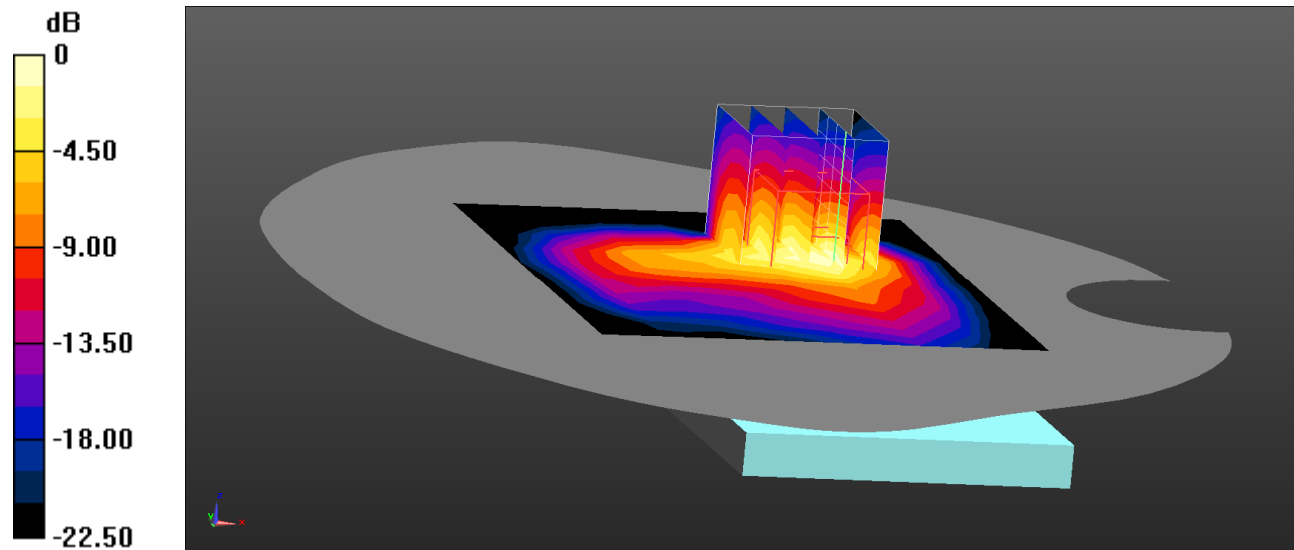

0 dB = 3.99 W/kg = 6.01 dBW/kg

Test Plot 10#

DUT: Smart phone; Type: G3 Mecha; Serial: 23N2_1

Communication System: UID 0, WCDMA (0); Frequency: 912.4 MHz;Duty Cycle: 1:1

Medium parameters used: $f = 912.4 \text{ MHz}$; $\sigma = 0.957 \text{ S/m}$; $\epsilon_r = 42.069$; $\rho = 1000 \text{ kg/m}^3$

Phantom section: Left Section

DASY5 Configuration:

- Probe: EX3DV4 - SN3701; ConvF(9.25, 9.25, 9.25) @ 912.4 MHz;
- Sensor-Surface: 4mm (Mechanical Surface Detection)
- Electronics: DAE4 Sn1325; Calibrated: 8/29/2022
- Phantom: SAM-Twin V8.0 P1aP2a; Type: QD 000 P41 AA ; Serial: 1962
- Measurement SW: DASY52, Version 52.10 (2);

Head Left Cheek/WCDMA Band 8 High/Area Scan (8x10x1): Measurement grid: dx=15mm, dy=15mm

Maximum value of SAR (measured) = 0.0143 W/kg

Head Left Cheek/WCDMA Band 8 High/Zoom Scan (5x5x7)/Cube 0: Measurement grid: dx=8mm, dy=8mm, dz=5mm

Reference Value = 0.897 V/m; Power Drift = 0.01 dB

Peak SAR (extrapolated) = 0.0170 W/kg

SAR(1 g) = 0.015 W/kg; SAR(10 g) = 0.011 W/kg

Maximum value of SAR (measured) = 0.0149 W/kg

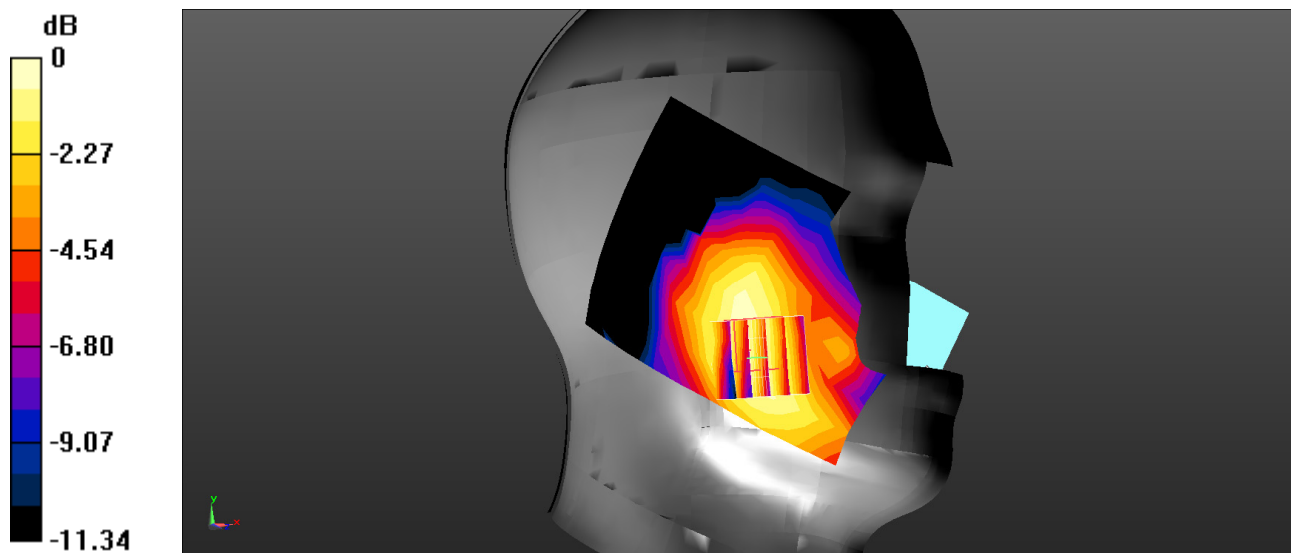

0 dB = 0.0149 W/kg = -18.27 dBW/kg

Test Plot 11#

DUT: Smart phone; Type: G3 Mecha; Serial: 23N2_1

Communication System: UID 0, WCDMA (0); Frequency: 882.6 MHz;Duty Cycle: 1:1

Medium parameters used: $f = 882.6 \text{ MHz}$; $\sigma = 0.935 \text{ S/m}$; $\epsilon_r = 42.196$; $\rho = 1000 \text{ kg/m}^3$

Phantom section: Flat Section

DASY5 Configuration:

- Probe: EX3DV4 - SN3701; ConvF(9.25, 9.25, 9.25) @ 882.6 MHz;
- Sensor-Surface: 4mm (Mechanical Surface Detection)
- Electronics: DAE4 Sn1325; Calibrated: 8/29/2022
- Phantom: SAM-Twin V8.0 P1aP2a; Type: QD 000 P41 AA ; Serial: 1962
- Measurement SW: DASY52, Version 52.10 (2);

Body Back/WCDMA Band 8 Low/Area Scan (8x10x1): Measurement grid: dx=15mm, dy=15mm

Maximum value of SAR (measured) = 0.0830 W/kg

Body Back/WCDMA Band 8 Low/Zoom Scan (5x5x7)/Cube 0: Measurement grid: dx=8mm, dy=8mm, dz=5mm

Reference Value = 9.510 V/m; Power Drift = 0.01 dB

Peak SAR (extrapolated) = 0.179 W/kg

SAR(1 g) = 0.097 W/kg; SAR(10 g) = 0.050 W/kg

Maximum value of SAR (measured) = 0.107 W/kg

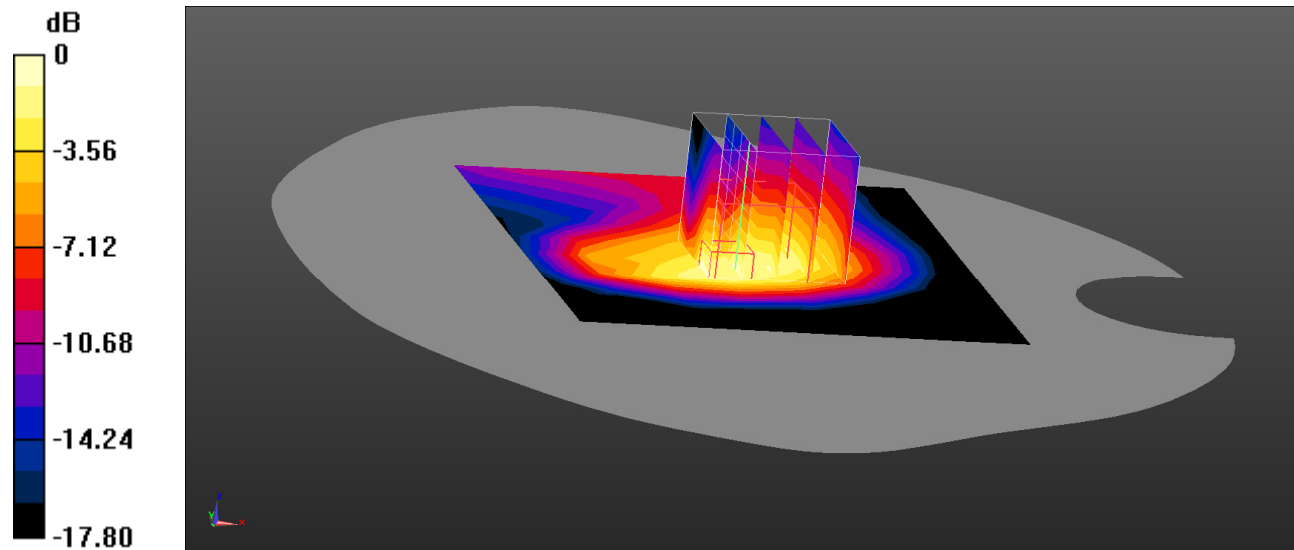

0 dB = 0.107 W/kg = -9.71 dBW/kg

Test Plot 12#

DUT: Smart phone; Type: G3 Mecha; Serial: 23N2_1

Communication System: UID 0, WCDMA (0); Frequency: 912.4 MHz;Duty Cycle: 1:1

Medium parameters used: $f = 912.4 \text{ MHz}$; $\sigma = 0.957 \text{ S/m}$; $\epsilon_r = 42.069$; $\rho = 1000 \text{ kg/m}^3$

Phantom section: Flat Section

DASY5 Configuration:

- Probe: EX3DV4 - SN3701; ConvF(9.25, 9.25, 9.25) @ 912.4 MHz;
- Sensor-Surface: 4mm (Mechanical Surface Detection)
- Electronics: DAE4 Sn1325; Calibrated: 8/29/2022
- Phantom: SAM-Twin V8.0 P1aP2a; Type: QD 000 P41 AA ; Serial: 1962
- Measurement SW: DASY52, Version 52.10 (2);

Limb Back/WCDMA Band 8 High/Area Scan (8x10x1): Measurement grid: dx=15mm, dy=15mm

Maximum value of SAR (measured) = 0.858 W/kg

Limb Back/WCDMA Band 8 High/Zoom Scan (5x5x7)/Cube 0: Measurement grid: dx=8mm, dy=8mm, dz=5mm

Reference Value = 16.71 V/m; Power Drift = -0.01 dB

Peak SAR (extrapolated) = 1.50 W/kg

SAR(1 g) = 0.727 W/kg; SAR(10 g) = 0.346 W/kg

Maximum value of SAR (measured) = 0.825 W/kg

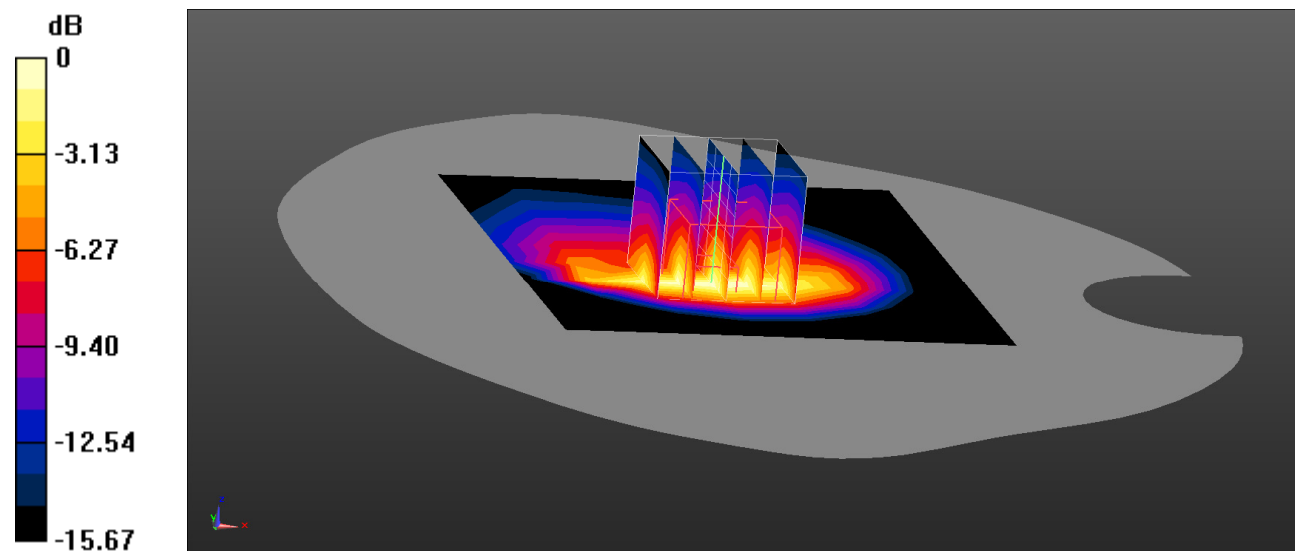

0 dB = 0.825 W/kg = -0.84 dBW/kg

Test Plot 13#

DUT: Smart phone; Type: G3 Mecha; Serial: 23N2_1

Communication System: UID 0, Generic FDD-LTE (0); Frequency: 1950 MHz;Duty Cycle: 1:1

Medium parameters used: $f = 1950 \text{ MHz}$; $\sigma = 1.334 \text{ S/m}$; $\epsilon_r = 41.27$; $\rho = 1000 \text{ kg/m}^3$

Phantom section: Right Section

DASY5 Configuration:

- Probe: EX3DV4 - SN3701; ConvF(7.65, 7.65, 7.65) @ 1950 MHz;
- Sensor-Surface: 4mm (Mechanical Surface Detection)
- Electronics: DAE4 Sn1325; Calibrated: 8/29/2022
- Phantom: SAM-Twin V8.0 P1aP2a; Type: QD 000 P41 AA ; Serial: 1962
- Measurement SW: DASY52, Version 52.10 (2);

Head Right Cheek/LTE Band 1 1RB Mid/Area Scan (8x10x1): Measurement grid: dx=15mm, dy=15mm

Maximum value of SAR (measured) = 1.65 W/kg

Head Right Cheek/LTE Band 1 1RB Mid/Zoom Scan (5x5x7)/Cube 0: Measurement grid: dx=8mm, dy=8mm, dz=5mm

Reference Value = 23.53 V/m; Power Drift = 0.17 dB

Peak SAR (extrapolated) = 2.79 W/kg

SAR(1 g) = 1.66 W/kg; SAR(10 g) = 0.940 W/kg

Maximum value of SAR (measured) = 1.79 W/kg

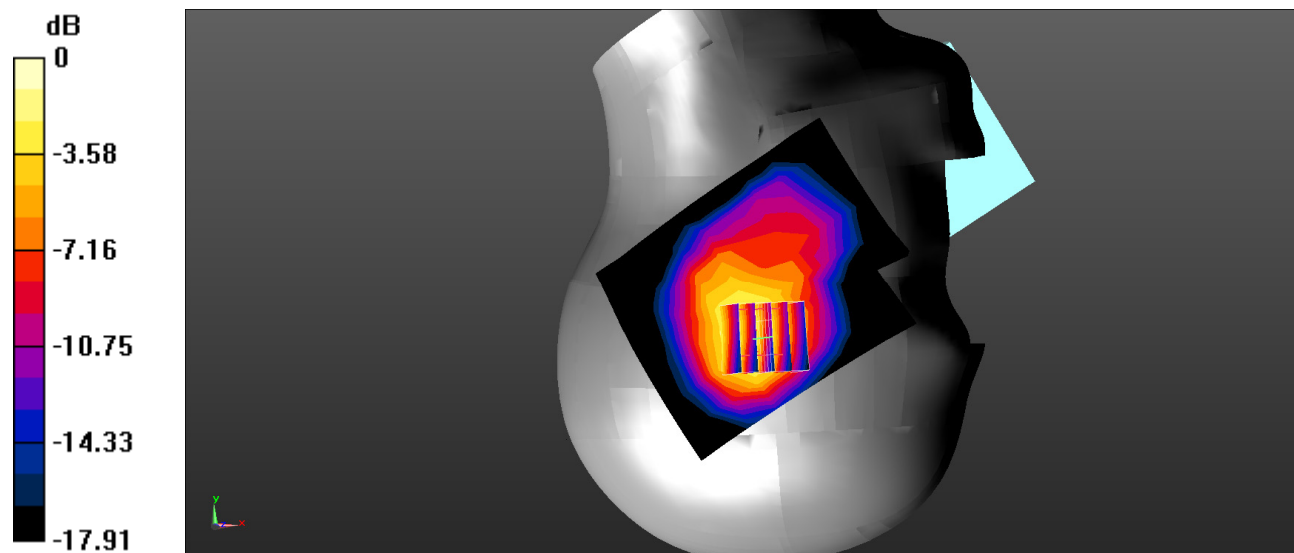

0 dB = 1.79 W/kg = 2.53 dBW/kg

Test Plot 14#

DUT: Smart phone; Type: G3 Mecha; Serial: 23N2_1

Communication System: UID 0, Generic FDD-LTE (0); Frequency: 1970 MHz;Duty Cycle: 1:1

Medium parameters used: $f = 1970 \text{ MHz}$; $\sigma = 1.35 \text{ S/m}$; $\epsilon_r = 41.197$; $\rho = 1000 \text{ kg/m}^3$

Phantom section: Flat Section

DASY5 Configuration:

- Probe: EX3DV4 - SN3701; ConvF(7.65, 7.65, 7.65) @ 1970 MHz;
- Sensor-Surface: 4mm (Mechanical Surface Detection)
- Electronics: DAE4 Sn1325; Calibrated: 8/29/2022
- Phantom: SAM-Twin V8.0 P1aP2a; Type: QD 000 P41 AA ; Serial: 1962
- Measurement SW: DASY52, Version 52.10 (2);

Body Back/LTE Band 1 1RB High/Area Scan (8x10x1): Measurement grid: $dx=15\text{mm}$, $dy=15\text{mm}$

Maximum value of SAR (measured) = 1.31 W/kg

Body Back/LTE Band 1 1RB High/Zoom Scan (5x5x7)/Cube 0: Measurement grid: $dx=8\text{mm}$, $dy=8\text{mm}$, $dz=5\text{mm}$

Reference Value = 24.82 V/m; Power Drift = 0.19 dB

Peak SAR (extrapolated) = 2.29 W/kg

SAR(1 g) = 1.19 W/kg; SAR(10 g) = 0.635 W/kg

Maximum value of SAR (measured) = 1.26 W/kg

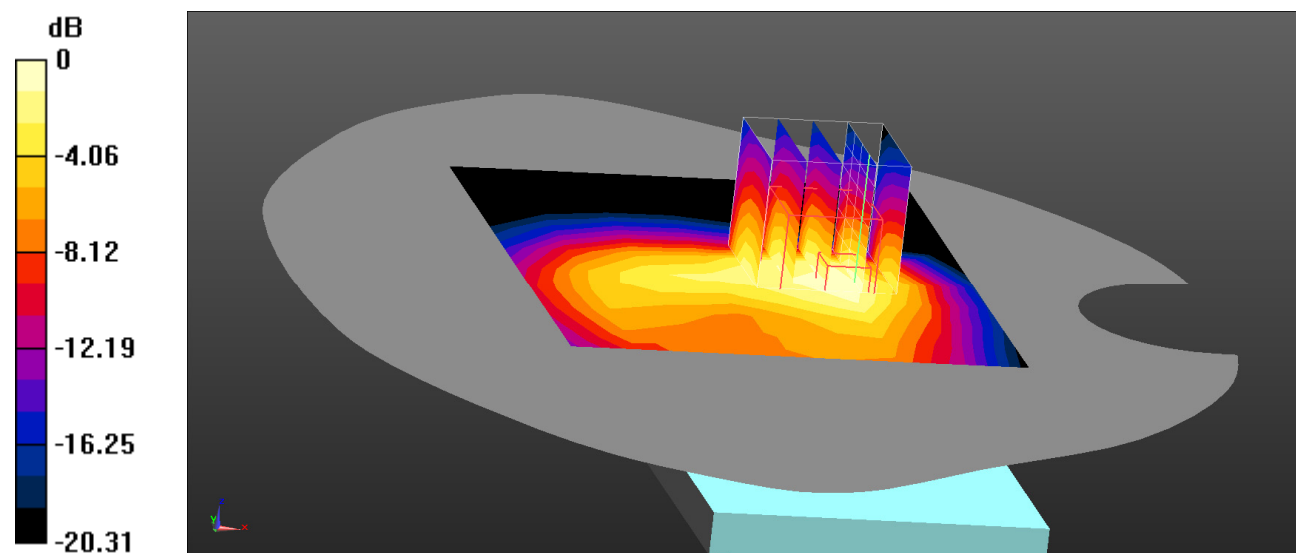

0 dB = 1.26 W/kg = 1.00 dBW/kg

Test Plot 15#

DUT: Smart phone; Type: G3 Mecha; Serial: 23N2_1

Communication System: UID 0, Generic FDD-LTE (0); Frequency: 1930 MHz;Duty Cycle: 1:1

Medium parameters used: $f = 1930 \text{ MHz}$; $\sigma = 1.368 \text{ S/m}$; $\epsilon_r = 40.861$; $\rho = 1000 \text{ kg/m}^3$

Phantom section: Flat Section

DASY5 Configuration:

- Probe: EX3DV4 - SN3701; ConvF(7.65, 7.65, 7.65) @ 1930 MHz;
- Sensor-Surface: 4mm (Mechanical Surface Detection)
- Electronics: DAE4 Sn1325; Calibrated: 8/29/2022
- Phantom: SAM-Twin V8.0 P1aP2a; Type: QD 000 P41 AA ; Serial: 1962
- Measurement SW: DASY52, Version 52.10 (2);

Limb Back/LTE Band 1 1RB Low/Area Scan (8x10x1): Measurement grid: $dx=15\text{mm}$, $dy=15\text{mm}$

Maximum value of SAR (measured) = 4.16 W/kg

Limb Back/LTE Band 1 1RB Low/Zoom Scan (5x5x7)/Cube 0: Measurement grid: $dx=8\text{mm}$, $dy=8\text{mm}$, $dz=5\text{mm}$

Reference Value = 37.26 V/m; Power Drift = -0.05 dB

Peak SAR (extrapolated) = 9.74 W/kg

SAR(1 g) = 4.08 W/kg; SAR(10 g) = 2.07 W/kg

Maximum value of SAR (measured) = 4.26 W/kg

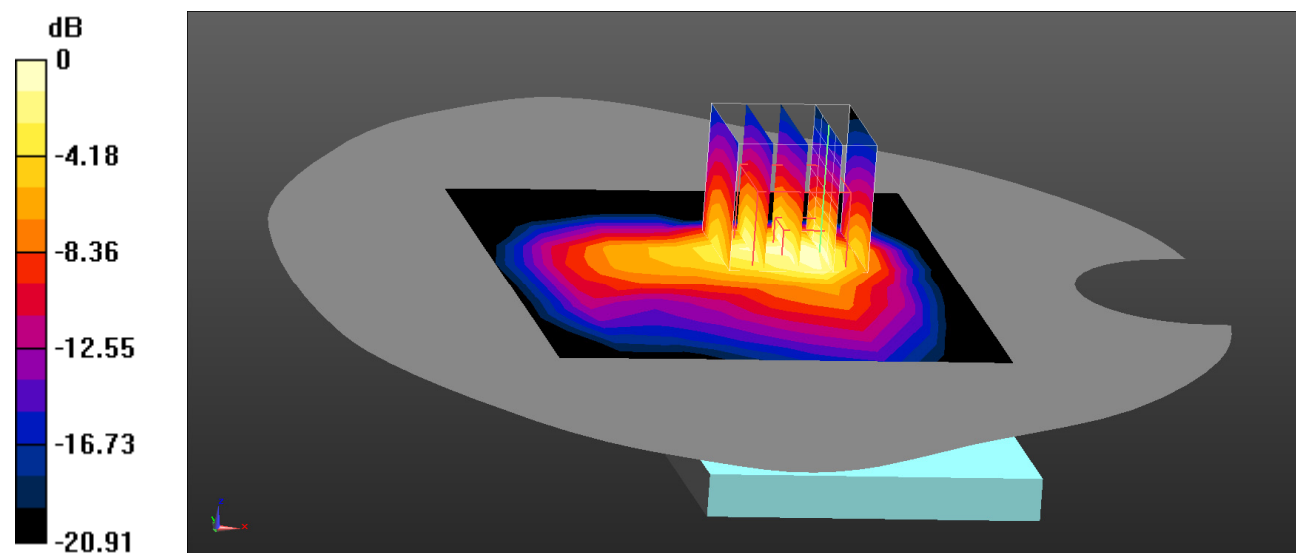

0 dB = 4.26 W/kg = 6.29 dBW/kg

Test Plot 16#

DUT: Smart phone; Type: G3 Mecha; Serial: 23N2_1

Communication System: UID 0, Generic FDD-LTE (0); Frequency: 1747.5 MHz;Duty Cycle: 1:1

Medium parameters used: $f = 1747.5 \text{ MHz}$; $\sigma = 1.414 \text{ S/m}$; $\epsilon_r = 41.143$; $\rho = 1000 \text{ kg/m}^3$

Phantom section: Right Section

DASY5 Configuration:

- Probe: EX3DV4 - SN3701; ConvF(7.97, 7.97, 7.97) @ 1747.5 MHz;
- Sensor-Surface: 4mm (Mechanical Surface Detection)
- Electronics: DAE4 Sn1325; Calibrated: 8/29/2022
- Phantom: SAM-Twin V8.0 P1aP2a; Type: QD 000 P41 AA ; Serial: 1962
- Measurement SW: DASY52, Version 52.10 (2);

Head Right Cheek/LTE Band 3 1RB Mid/Area Scan (8x10x1): Measurement grid: dx=15mm, dy=15mm

Maximum value of SAR (measured) = 1.78 W/kg

Head Right Cheek/LTE Band 3 1RB Mid/Zoom Scan (5x5x7)/Cube 0: Measurement grid: dx=8mm, dy=8mm, dz=5mm

Reference Value = 22.63 V/m; Power Drift = -0.18 dB

Peak SAR (extrapolated) = 2.91 W/kg

SAR(1 g) = 1.66 W/kg; SAR(10 g) = 0.957 W/kg

Maximum value of SAR (measured) = 1.85 W/kg

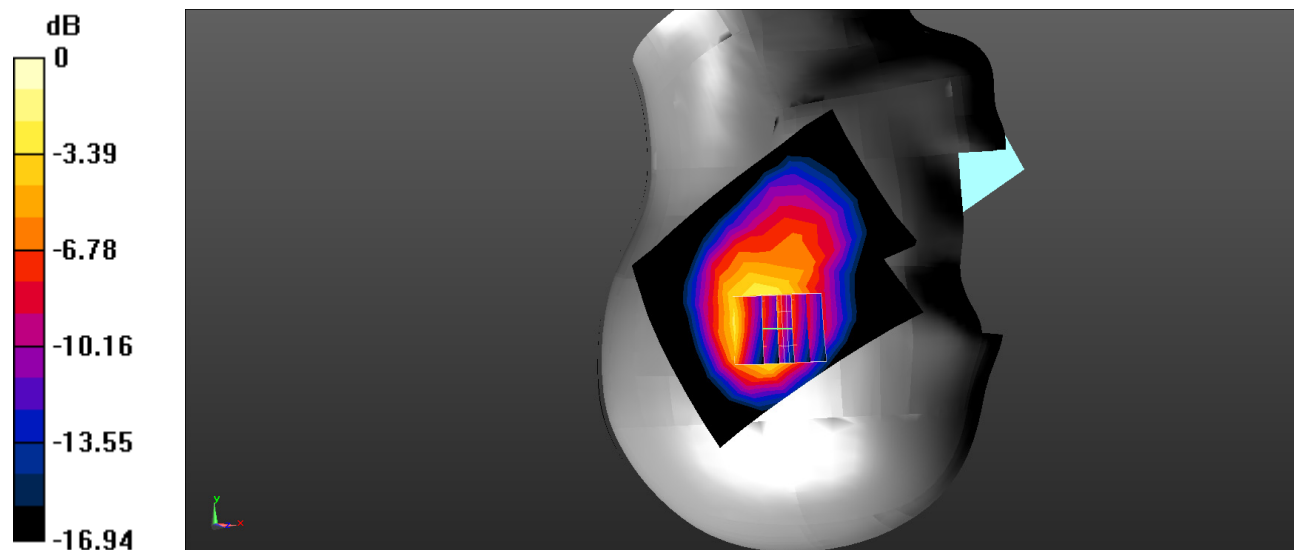

0 dB = 1.85 W/kg = 2.67 dBW/kg

Test Plot 17#

DUT: Smart phone; Type: G3 Mecha; Serial: 23N2_1

Communication System: UID 0, Generic FDD-LTE (0); Frequency: 1775 MHz;Duty Cycle: 1:1

Medium parameters used: $f = 1775 \text{ MHz}$; $\sigma = 1.416 \text{ S/m}$; $\epsilon_r = 40.921$; $\rho = 1000 \text{ kg/m}^3$

Phantom section: Flat Section

DASY5 Configuration:

- Probe: EX3DV4 - SN3701; ConvF(7.97, 7.97, 7.97) @ 1775 MHz;
- Sensor-Surface: 4mm (Mechanical Surface Detection)
- Electronics: DAE4 Sn1325; Calibrated: 8/29/2022
- Phantom: SAM-Twin V8.0 P1aP2a; Type: QD 000 P41 AA ; Serial: 1962
- Measurement SW: DASY52, Version 52.10 (2);

Body Back/LTE Band 3 1RB High/Area Scan (8x10x1): Measurement grid: dx=15mm, dy=15mm

Maximum value of SAR (measured) = 1.21 W/kg

Body Back/LTE Band 3 1RB High/Zoom Scan (5x5x7)/Cube 0: Measurement grid: dx=8mm, dy=8mm, dz=5mm

Reference Value = 24.98 V/m; Power Drift = 0.13 dB

Peak SAR (extrapolated) = 2.16 W/kg

SAR(1 g) = 1.11 W/kg; SAR(10 g) = 0.622 W/kg

Maximum value of SAR (measured) = 1.21 W/kg

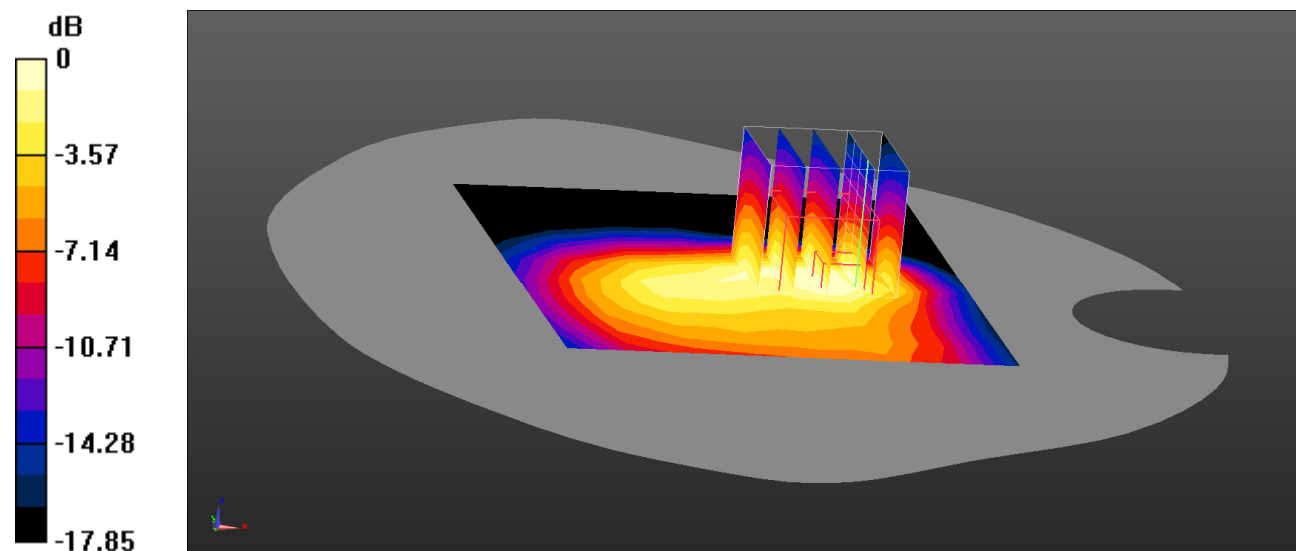

0 dB = 1.21 W/kg = 0.83 dBW/kg

Test Plot 18#

DUT: Smart phone; Type: G3 Mecha; Serial: 23N2_1

Communication System: UID 0, Generic FDD-LTE (0); Frequency: 1775 MHz;Duty Cycle: 1:1

Medium parameters used: $f = 1775 \text{ MHz}$; $\sigma = 1.416 \text{ S/m}$; $\epsilon_r = 40.921$; $\rho = 1000 \text{ kg/m}^3$

Phantom section: Flat Section

DASY5 Configuration:

- Probe: EX3DV4 - SN3701; ConvF(7.97, 7.97, 7.97) @ 1775 MHz;
- Sensor-Surface: 4mm (Mechanical Surface Detection)
- Electronics: DAE4 Sn1325; Calibrated: 8/29/2022
- Phantom: SAM-Twin V8.0 P1aP2a; Type: QD 000 P41 AA ; Serial: 1962
- Measurement SW: DASY52, Version 52.10 (2);

Limb Back/LTE Band 3 1RB High/Area Scan (8x10x1): Measurement grid: $dx=15\text{mm}$, $dy=15\text{mm}$

Maximum value of SAR (measured) = 4.42 W/kg

Limb Back/LTE Band 3 1RB High/Zoom Scan (5x5x7)/Cube 0: Measurement grid: $dx=8\text{mm}$, $dy=8\text{mm}$, $dz=5\text{mm}$

Reference Value = 41.02 V/m; Power Drift = -0.01 dB

Peak SAR (extrapolated) = 10.1 W/kg

SAR(1 g) = 4.3 W/kg; SAR(10 g) = 2.25 W/kg

Maximum value of SAR (measured) = 4.60 W/kg

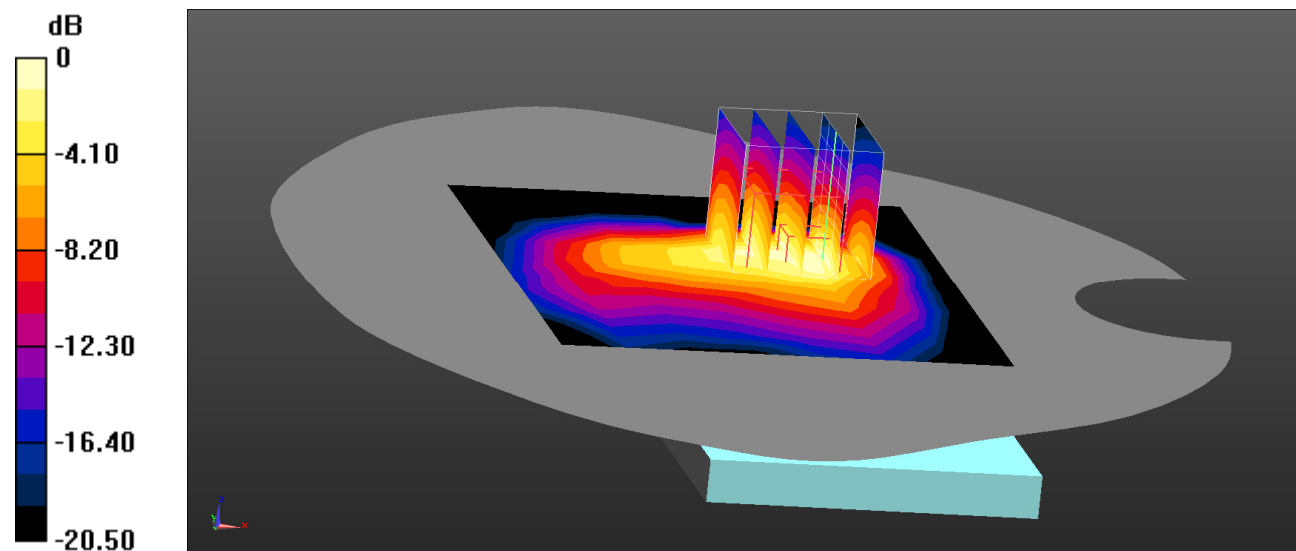

0 dB = 4.60 W/kg = 6.63 dBW/kg

Test Plot 19#

DUT: Smart phone; Type: G3 Mecha; Serial: 23N2_1

Communication System: UID 0, Generic FDD-LTE (0); Frequency: 910 MHz;Duty Cycle: 1:1

Medium parameters used: $f = 910 \text{ MHz}$; $\sigma = 0.955 \text{ S/m}$; $\epsilon_r = 42.045$; $\rho = 1000 \text{ kg/m}^3$

Phantom section: Left Section

DASY5 Configuration:

- Probe: EX3DV4 - SN3701; ConvF(9.25, 9.25, 9.25) @ 910 MHz;
- Sensor-Surface: 4mm (Mechanical Surface Detection)
- Electronics: DAE4 Sn1325; Calibrated: 8/29/2022
- Phantom: SAM-Twin V8.0 P1aP2a; Type: QD 000 P41 AA ; Serial: 1962
- Measurement SW: DASY52, Version 52.10 (2);

Head Left Cheek/LTE Band 8 1RB High/Area Scan (8x10x1): Measurement grid: $dx=15\text{mm}$, $dy=15\text{mm}$

Maximum value of SAR (measured) = 0.0102 W/kg

Head Left Cheek/LTE Band 8 1RB High/Zoom Scan (5x5x7)/Cube 0: Measurement grid: $dx=8\text{mm}$, $dy=8\text{mm}$, $dz=5\text{mm}$

Reference Value = 0.148 V/m; Power Drift = 0.02 dB

Peak SAR (extrapolated) = 0.0120 W/kg

SAR(1 g) = 0.00997 W/kg; SAR(10 g) = 0.00798 W/kg

Maximum value of SAR (measured) = 0.0102 W/kg

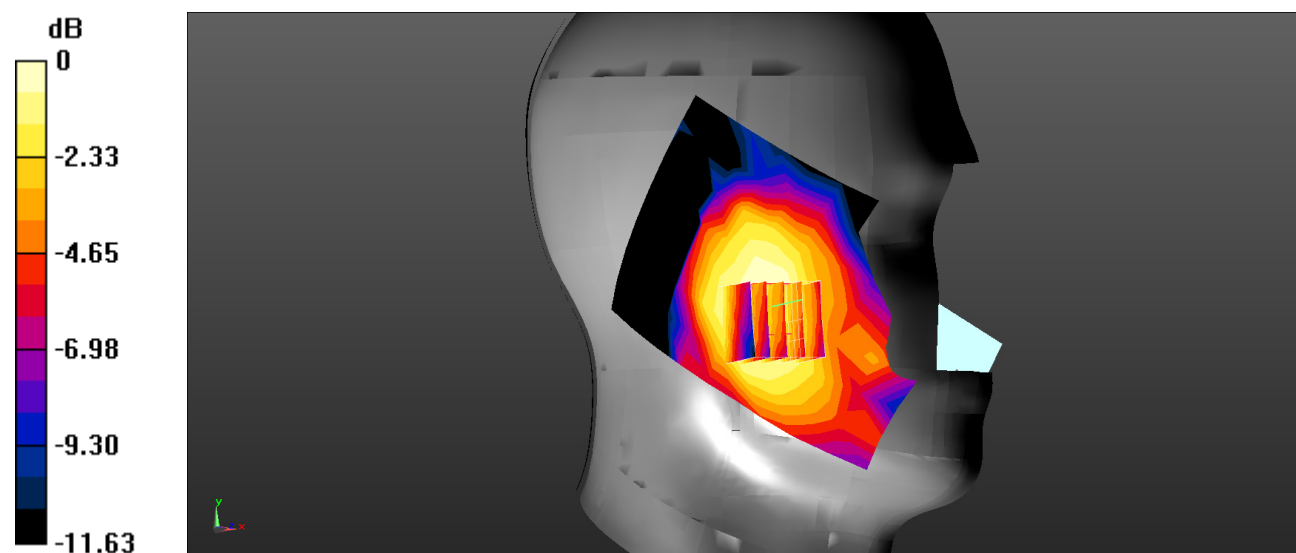

0 dB = 0.0102 W/kg = -19.91 dBW/kg

Test Plot 20#

DUT: Smart phone; Type: G3 Mecha; Serial: 23N2_1

Communication System: UID 0, Generic FDD-LTE (0); Frequency: 910 MHz;Duty Cycle: 1:1

Medium parameters used: $f = 910 \text{ MHz}$; $\sigma = 0.955 \text{ S/m}$; $\epsilon_r = 42.045$; $\rho = 1000 \text{ kg/m}^3$

Phantom section: Flat Section

DASY5 Configuration:

- Probe: EX3DV4 - SN3701; ConvF(9.25, 9.25, 9.25) @ 910 MHz;
- Sensor-Surface: 4mm (Mechanical Surface Detection)
- Electronics: DAE4 Sn1325; Calibrated: 8/29/2022
- Phantom: SAM-Twin V8.0 P1aP2a; Type: QD 000 P41 AA ; Serial: 1962
- Measurement SW: DASY52, Version 52.10 (2);

Body Back/LTE Band 8 1RB High/Area Scan (8x10x1): Measurement grid: dx=15mm, dy=15mm

Maximum value of SAR (measured) = 0.115 W/kg

Body Back/LTE Band 8 1RB High/Zoom Scan (5x5x7)/Cube 0: Measurement grid: dx=8mm, dy=8mm, dz=5mm

Reference Value = 8.501 V/m; Power Drift = -0.15 dB

Peak SAR (extrapolated) = 0.182 W/kg

SAR(1 g) = 0.106 W/kg; SAR(10 g) = 0.057 W/kg

Maximum value of SAR (measured) = 0.111 W/kg

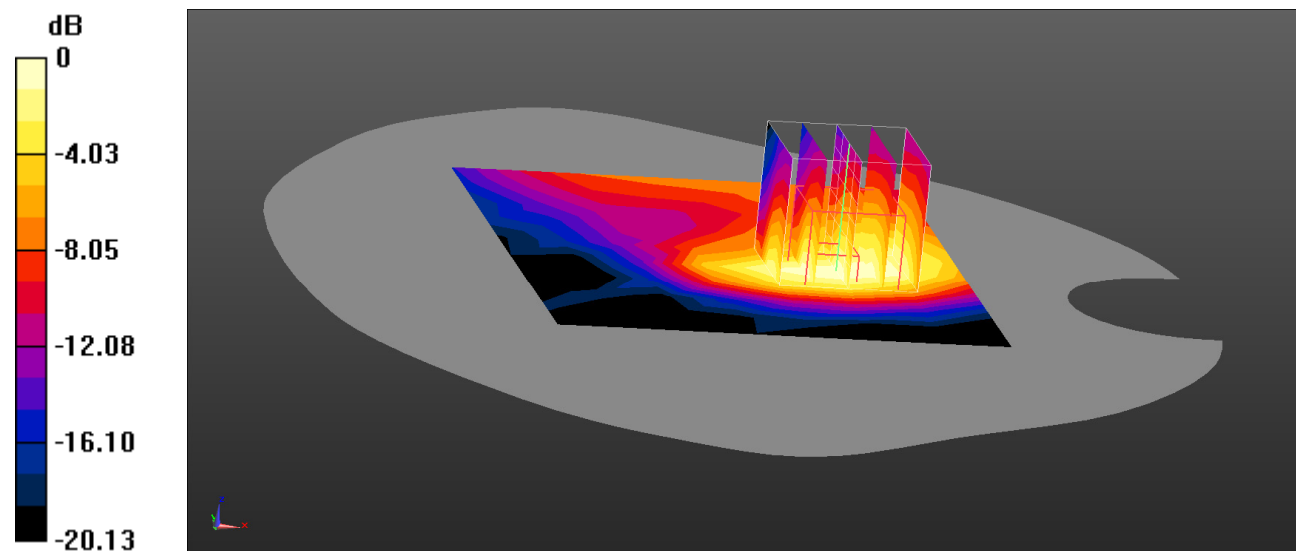

0 dB = 0.111 W/kg = -9.55 dBW/kg

Test Plot 21#

DUT: Smart phone; Type: G3 Mecha; Serial: 23N2_1

Communication System: UID 0, Generic FDD-LTE (0); Frequency: 910 MHz;Duty Cycle: 1:1

Medium parameters used: $f = 910 \text{ MHz}$; $\sigma = 0.955 \text{ S/m}$; $\epsilon_r = 42.045$; $\rho = 1000 \text{ kg/m}^3$

Phantom section: Flat Section

DASY5 Configuration:

- Probe: EX3DV4 - SN3701; ConvF(9.25, 9.25, 9.25) @ 910 MHz;
- Sensor-Surface: 4mm (Mechanical Surface Detection)
- Electronics: DAE4 Sn1325; Calibrated: 8/29/2022
- Phantom: SAM-Twin V8.0 P1aP2a; Type: QD 000 P41 AA ; Serial: 1962
- Measurement SW: DASY52, Version 52.10 (2);

Limb Back/LTE Band 8 1RB High/Area Scan (8x10x1): Measurement grid: $dx=15\text{mm}$, $dy=15\text{mm}$

Maximum value of SAR (measured) = 0.590 W/kg

Limb Back/LTE Band 8 1RB High/Zoom Scan (5x5x7)/Cube 0: Measurement grid: $dx=8\text{mm}$, $dy=8\text{mm}$, $dz=5\text{mm}$

Reference Value = 23.94 V/m; Power Drift = -0.14 dB

Peak SAR (extrapolated) = 1.69 W/kg

SAR(1 g) = 0.832 W/kg; SAR(10 g) = 0.403 W/kg

Maximum value of SAR (measured) = 1.01 W/kg

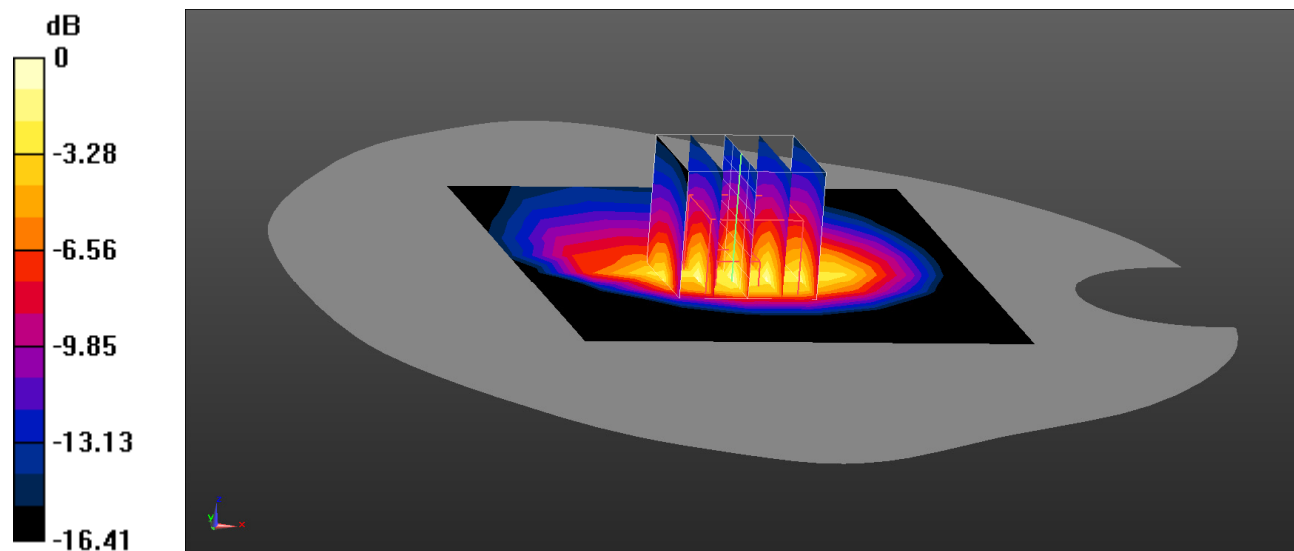

0 dB = 1.01 W/kg = 0.04 dBW/kg

Test Plot 22#

DUT: Smart phone; Type: G3 Mecha; Serial: 23N2_1

Communication System: UID 0, Generic FDD-LTE (0); Frequency: 728 MHz;Duty Cycle: 1:1

Medium parameters used: $f = 728 \text{ MHz}$; $\sigma = 0.906 \text{ S/m}$; $\epsilon_r = 42.326$; $\rho = 1000 \text{ kg/m}^3$

Phantom section: Right Section

DASY5 Configuration:

- Probe: EX3DV4 - SN3701; ConvF(9.71, 9.71, 9.71) @ 728 MHz;
- Sensor-Surface: 4mm (Mechanical Surface Detection)
- Electronics: DAE4 Sn1325; Calibrated: 8/29/2022
- Phantom: SAM-Twin V8.0 P1aP2a; Type: QD 000 P41 AA ; Serial: 1962
- Measurement SW: DASY52, Version 52.10 (2);

Head Right Cheek/LTE Band 28 1RB Mid/Area Scan (8x10x1): Measurement grid: $dx=15\text{mm}$, $dy=15\text{mm}$

Maximum value of SAR (measured) = 0.0794 W/kg

Head Right Cheek/LTE Band 28 1RB Mid/Zoom Scan (5x5x7)/Cube 0: Measurement grid: $dx=8\text{mm}$, $dy=8\text{mm}$, $dz=5\text{mm}$

Reference Value = 0.9460 V/m; Power Drift = 0.03 dB

Peak SAR (extrapolated) = 0.0950 W/kg

SAR(1 g) = 0.079 W/kg; SAR(10 g) = 0.063 W/kg

Maximum value of SAR (measured) = 0.0824 W/kg

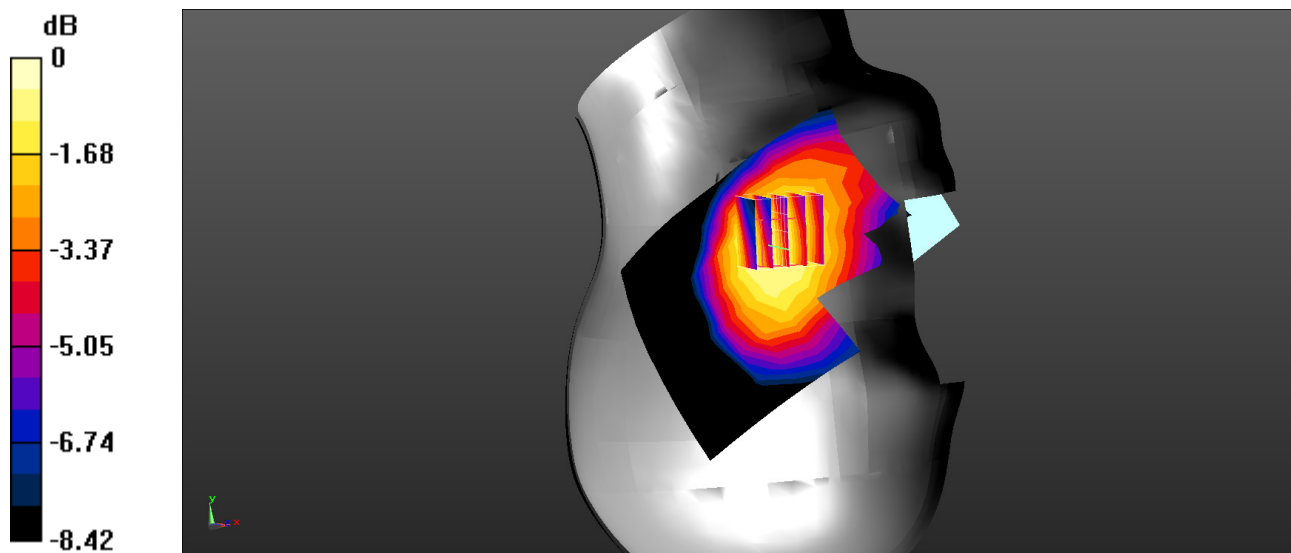

0 dB = 0.0824 W/kg = -10.84 dBW/kg

Test Plot 23#

DUT: Smart phone; Type: G3 Mecha; Serial: 23N2_1

Communication System: UID 0, Generic FDD-LTE (0); Frequency: 738 MHz;Duty Cycle: 1:1

Medium parameters used: $f = 738 \text{ MHz}$; $\sigma = 0.908 \text{ S/m}$; $\epsilon_r = 42.134$; $\rho = 1000 \text{ kg/m}^3$

Phantom section: Flat Section

DASY5 Configuration:

- Probe: EX3DV4 - SN3701; ConvF(9.71, 9.71, 9.71) @ 738 MHz;
- Sensor-Surface: 4mm (Mechanical Surface Detection)
- Electronics: DAE4 Sn1325; Calibrated: 8/29/2022
- Phantom: SAM-Twin V8.0 P1aP2a; Type: QD 000 P41 AA ; Serial: 1962
- Measurement SW: DASY52, Version 52.10 (2);

Body Back/LTE Band 28 1RB High/Area Scan (8x10x1): Measurement grid: dx=15mm, dy=15mm

Maximum value of SAR (measured) = 0.375 W/kg

Body Back/LTE Band 28 1RB High/Zoom Scan (5x5x7)/Cube 0: Measurement grid: dx=8mm, dy=8mm, dz=5mm

Reference Value = 17.07 V/m; Power Drift = -0.08 dB

Peak SAR (extrapolated) = 0.785 W/kg

SAR(1 g) = 0.405 W/kg; SAR(10 g) = 0.217 W/kg

Maximum value of SAR (measured) = 0.461 W/kg

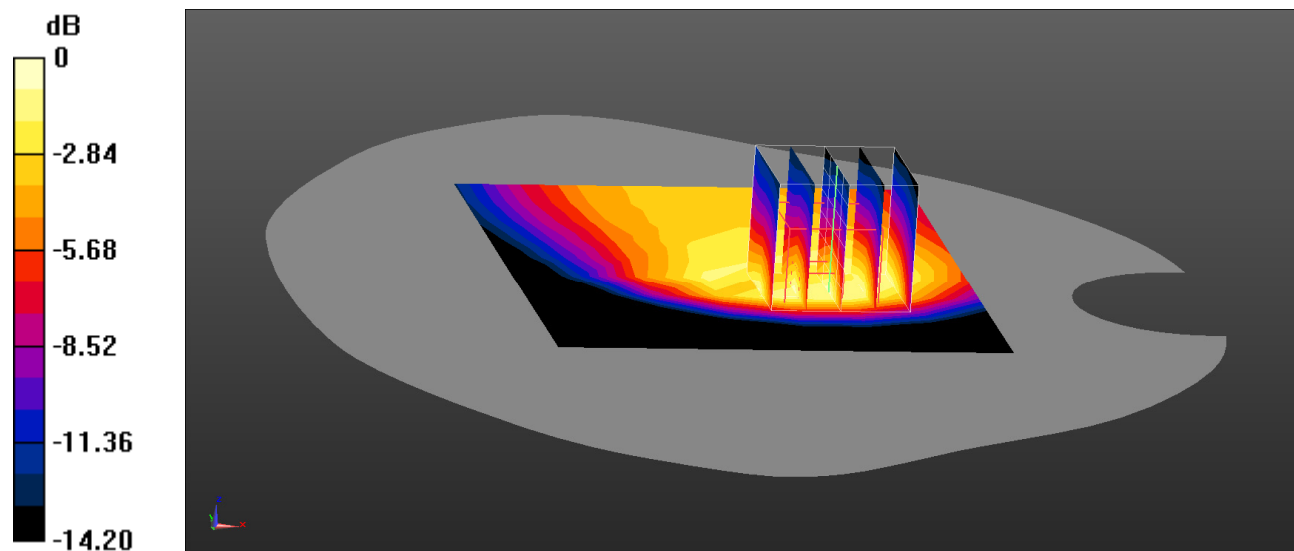

0 dB = 0.461 W/kg = -3.36 dBW/kg

Test Plot 24#

DUT: Smart phone; Type: G3 Mecha; Serial: 23N2_1

Communication System: UID 0, Generic FDD-LTE (0); Frequency: 713 MHz;Duty Cycle: 1:1

Medium parameters used: $f = 713 \text{ MHz}$; $\sigma = 0.902 \text{ S/m}$; $\epsilon_r = 42.614$; $\rho = 1000 \text{ kg/m}^3$

Phantom section: Flat Section

DASY5 Configuration:

- Probe: EX3DV4 - SN3701; ConvF(9.71, 9.71, 9.71) @ 713 MHz;
- Sensor-Surface: 4mm (Mechanical Surface Detection)
- Electronics: DAE4 Sn1325; Calibrated: 8/29/2022
- Phantom: SAM-Twin V8.0 P1aP2a; Type: QD 000 P41 AA ; Serial: 1962
- Measurement SW: DASY52, Version 52.10 (2);

Limb Back/LTE Band 28 1RB Low/Area Scan (8x10x1): Measurement grid: dx=15mm, dy=15mm

Maximum value of SAR (measured) = 1.70 W/kg

Limb Back/LTE Band 28 1RB Low/Zoom Scan (5x5x7)/Cube 0: Measurement grid: dx=8mm, dy=8mm, dz=5mm

Reference Value = 36.18 V/m; Power Drift = -0.04 dB

Peak SAR (extrapolated) = 5.98 W/kg

SAR(1 g) = 2 W/kg; SAR(10 g) = 0.907 W/kg

Maximum value of SAR (measured) = 2.24 W/kg

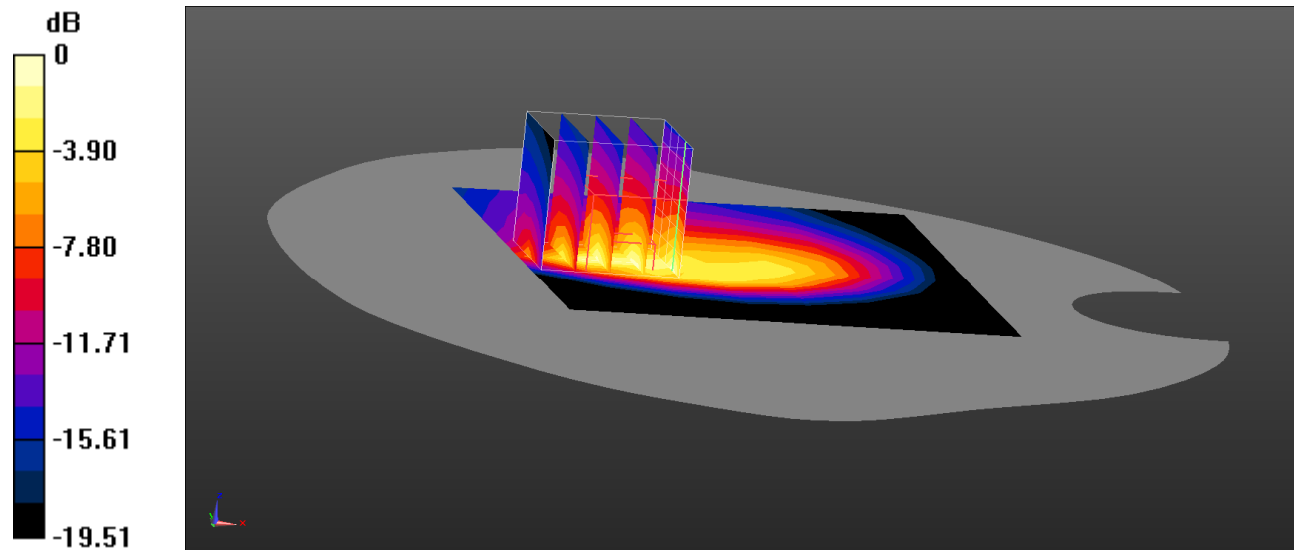

0 dB = 2.24 W/kg = 3.50 dBW/kg

Test Plot 25#

DUT: Smart phone; Type: G3 Mecha; Serial: 23N2_1

Communication System: UID 0, Generic TDD-LTE (0); Frequency: 2390 MHz;Duty Cycle: 1:1.58125

Medium parameters used: $f = 2390 \text{ MHz}$; $\sigma = 1.779 \text{ S/m}$; $\epsilon_r = 40.436$; $\rho = 1000 \text{ kg/m}^3$

Phantom section: Left Section

DASY5 Configuration:

- Probe: EX3DV4 - SN3701; ConvF(7.5, 7.5, 7.5) @ 2390 MHz;
- Sensor-Surface: 4mm (Mechanical Surface Detection)
- Electronics: DAE4 Sn1325; Calibrated: 8/29/2022
- Phantom: SAM-Twin V8.0 P1aP2a; Type: QD 000 P41 AA ; Serial: 1962
- Measurement SW: DASY52, Version 52.10 (2);

Head Left Cheek/LTE Band 40 1RB High/Area Scan (11x14x1): Measurement grid: dx=10mm, dy=10mm

Maximum value of SAR (measured) = 0.107 W/kg

Head Left Cheek/LTE Band 40 1RB High/Zoom Scan (7x7x7)/Cube 0: Measurement grid: dx=5mm, dy=5mm, dz=5mm

Reference Value = 1.578 V/m; Power Drift = -0.09 dB

Peak SAR (extrapolated) = 0.164 W/kg

SAR(1 g) = 0.102 W/kg; SAR(10 g) = 0.058 W/kg

Maximum value of SAR (measured) = 0.112 W/kg

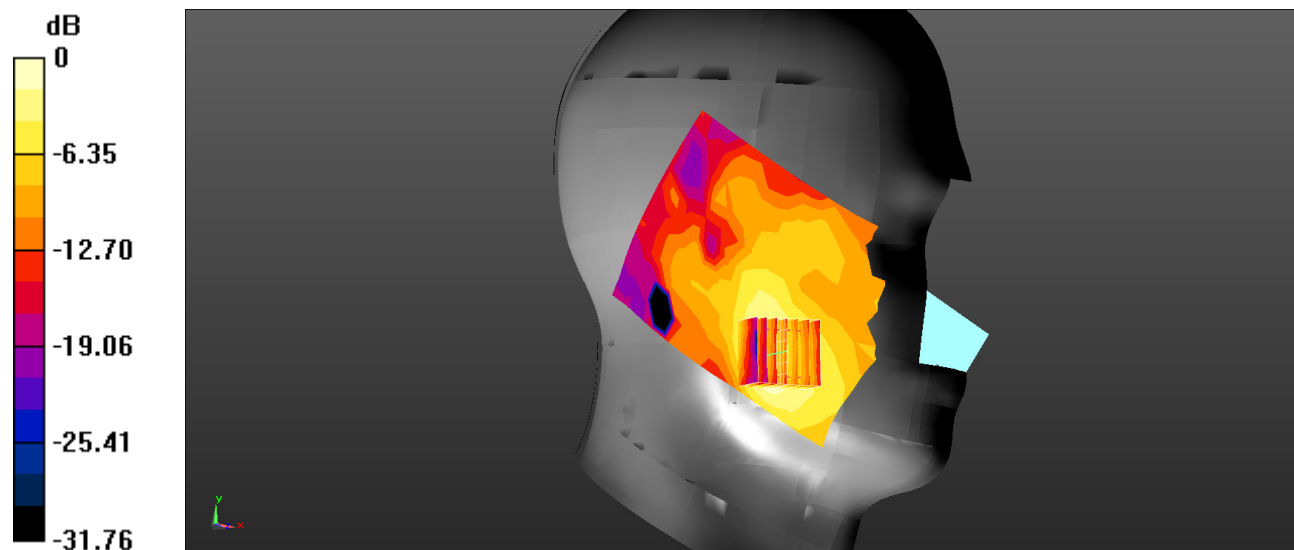

0 dB = 0.112 W/kg = -9.51 dBW/kg

Test Plot 26#

DUT: Smart phone; Type: G3 Mecha; Serial: 23N2_1

Communication System: UID 0, Generic TDD-LTE (0); Frequency: 2390 MHz;Duty Cycle: 1:1.58125

Medium parameters used: $f = 2390 \text{ MHz}$; $\sigma = 1.779 \text{ S/m}$; $\epsilon_r = 40.436$; $\rho = 1000 \text{ kg/m}^3$

Phantom section: Flat Section

DASY5 Configuration:

- Probe: EX3DV4 - SN3701; ConvF(7.5, 7.5, 7.5) @ 2390 MHz;
- Sensor-Surface: 4mm (Mechanical Surface Detection)
- Electronics: DAE4 Sn1325; Calibrated: 8/29/2022
- Phantom: SAM-Twin V8.0 P1aP2a; Type: QD 000 P41 AA ; Serial: 1962
- Measurement SW: DASY52, Version 52.10 (2);

Body Back/LTE Band 40 1RB High/Area Scan (11x13x1): Measurement grid: $dx=10\text{mm}$, $dy=10\text{mm}$

Maximum value of SAR (measured) = 0.358 W/kg

Body Back/LTE Band 40 1RB High/Zoom Scan (7x7x7)/Cube 0: Measurement grid: $dx=5\text{mm}$, $dy=5\text{mm}$, $dz=5\text{mm}$

Reference Value = 12.15 V/m; Power Drift = -0.19 dB

Peak SAR (extrapolated) = 0.637 W/kg

SAR(1 g) = 0.337 W/kg; SAR(10 g) = 0.175 W/kg

Maximum value of SAR (measured) = 0.377 W/kg

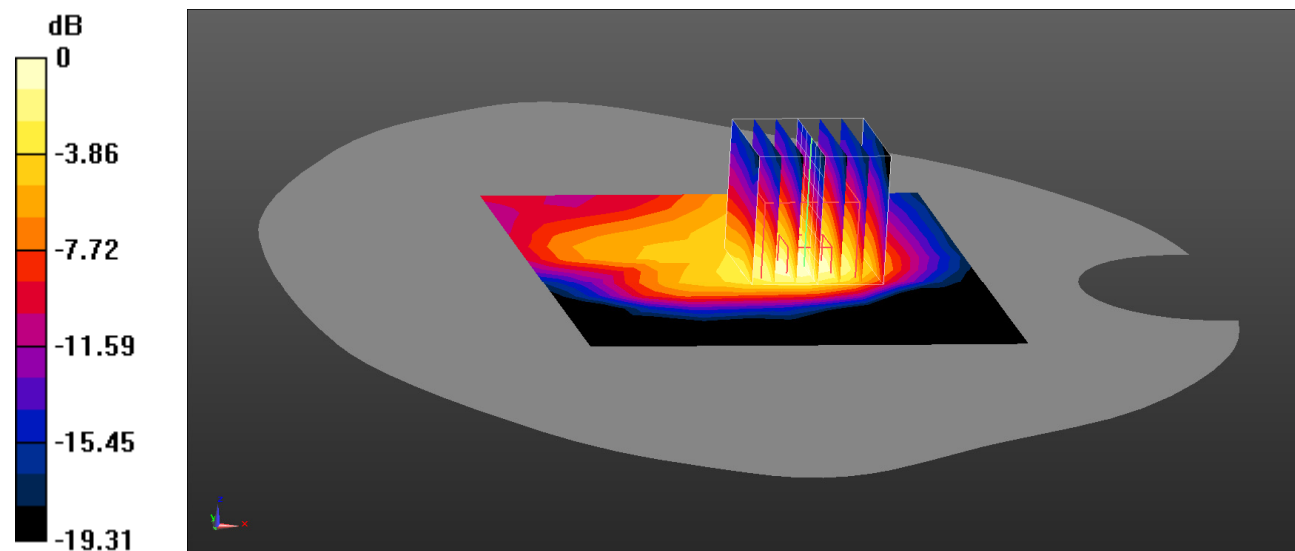

0 dB = 0.377 W/kg = -4.24 dBW/kg

Test Plot 27#

DUT: Smart phone; Type: C1 MAX; Serial: 23N2_1

Communication System: UID 0, Generic TDD-LTE (0); Frequency: 2390 MHz;Duty Cycle: 1:1.58125

Medium parameters used: $f = 2390$ MHz; $\sigma = 1.779$ S/m; $\epsilon_r = 40.436$; $\rho = 1000$ kg/m³

Phantom section: Flat Section

DASY5 Configuration:

- Probe: EX3DV4 - SN3701; ConvF(7.5, 7.5, 7.5) @ 2390 MHz;
- Sensor-Surface: 4mm (Mechanical Surface Detection)
- Electronics: DAE4 Sn1325; Calibrated: 8/29/2022
- Phantom: SAM-Twin V8.0 P1aP2a; Type: QD 000 P41 AA ; Serial: 1962
- Measurement SW: DASY52, Version 52.10 (2);

Limb Back/LTE Band 40 1RB High/Area Scan (11x11x1): Measurement grid: dx=10mm, dy=10mm

Maximum value of SAR (measured) = 3.61 W/kg

Limb Back/LTE Band 40 1RB High/Zoom Scan (7x7x7)/Cube 0: Measurement grid: dx=5mm, dy=5mm, dz=5mm

Reference Value = 0.4840 V/m; Power Drift = 0.12 dB

Peak SAR (extrapolated) = 6.65 W/kg

SAR(1 g) = 3.1 W/kg; SAR(10 g) = 1.41 W/kg

Maximum value of SAR (measured) = 3.49 W/kg

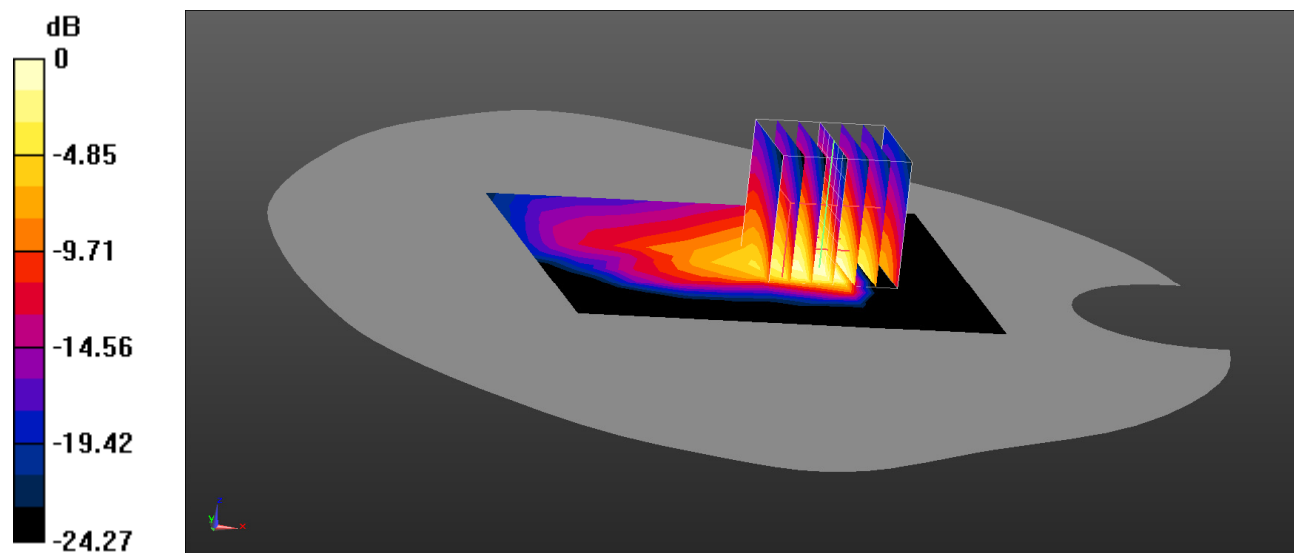

0 dB = 3.49 W/kg = 5.43 dBW/kg

Test Plot 28#

DUT: Smart phone; Type: G3 Mecha; Serial: 23N2_1

Communication System: UID 0, 2.4G WIFI (0); Frequency: 2472 MHz;Duty Cycle: 1:1

Medium parameters used: $f = 2472 \text{ MHz}$; $\sigma = 1.862 \text{ S/m}$; $\epsilon_r = 40.325$; $\rho = 1000 \text{ kg/m}^3$

Phantom section: Left Section

DASY5 Configuration:

- Probe: EX3DV4 - SN3701; ConvF(7.25, 7.25, 7.25) @ 2472 MHz;
- Sensor-Surface: 4mm (Mechanical Surface Detection)
- Electronics: DAE4 Sn1325; Calibrated: 8/29/2022
- Phantom: SAM-Twin V8.0 P1aP2a; Type: QD 000 P41 AA ; Serial: 1962
- Measurement SW: DASY52, Version 52.10 (2);

Head Left Cheek/WLAN 802.11b High/Area Scan (11x11x1): Measurement grid: dx=10mm, dy=10mm

Maximum value of SAR (measured) = 1.38 W/kg

Head Left Cheek/WLAN 802.11b High/Zoom Scan (7x7x7)/Cube 0: Measurement grid: dx=5mm, dy=5mm, dz=5mm

Reference Value = 9.749 V/m; Power Drift = -0.10 dB

Peak SAR (extrapolated) = 2.25 W/kg

SAR(1 g) = 1.29 W/kg; SAR(10 g) = 0.711 W/kg

Maximum value of SAR (measured) = 1.43 W/kg

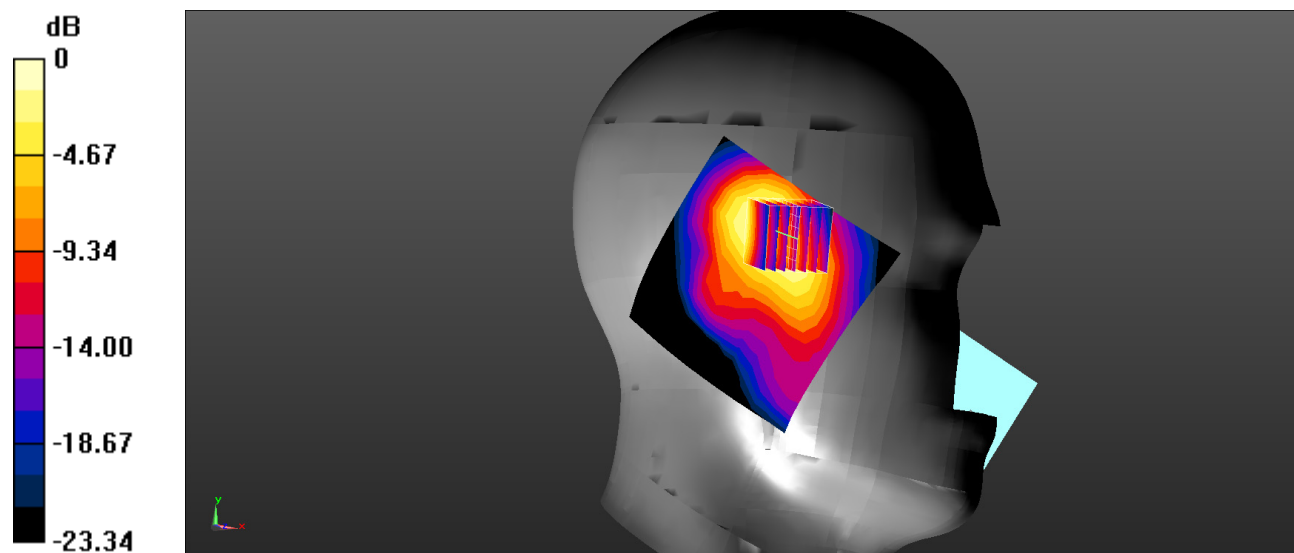

0 dB = 1.43 W/kg = 1.55 dBW/kg

Test Plot 29#

DUT: Smart phone; Type: G3 Mecha ; Serial: 23N2_1

Communication System: UID 0, 2.4G WIFI (0); Frequency: 2472 MHz;Duty Cycle: 1:1

Medium parameters used: $f = 2472 \text{ MHz}$; $\sigma = 1.862 \text{ S/m}$; $\epsilon_r = 40.325$; $\rho = 1000 \text{ kg/m}^3$

Phantom section: Flat Section

DASY5 Configuration:

- Probe: EX3DV4 - SN3701; ConvF(7.25, 7.25, 7.25) @ 2472 MHz;
- Sensor-Surface: 4mm (Mechanical Surface Detection)
- Electronics: DAE4 Sn1325; Calibrated: 8/29/2022
- Phantom: SAM-Twin V8.0 P1aP2a; Type: QD 000 P41 AA ; Serial: 1962
- Measurement SW: DASY52, Version 52.10 (2);

Body Back/WLAN 802.11b High/Area Scan (11x11x1): Measurement grid: $dx=10\text{mm}$, $dy=10\text{mm}$

Maximum value of SAR (measured) = 0.966 W/kg

Body Back/WLAN 802.11b High/Zoom Scan (7x7x7)/Cube 0: Measurement grid: $dx=5\text{mm}$, $dy=5\text{mm}$, $dz=5\text{mm}$

Reference Value = 19.45 V/m; Power Drift = 0.16 dB

Peak SAR (extrapolated) = 1.84 W/kg

SAR(1 g) = 0.850 W/kg; SAR(10 g) = 0.406 W/kg

Maximum value of SAR (measured) = 0.963 W/kg

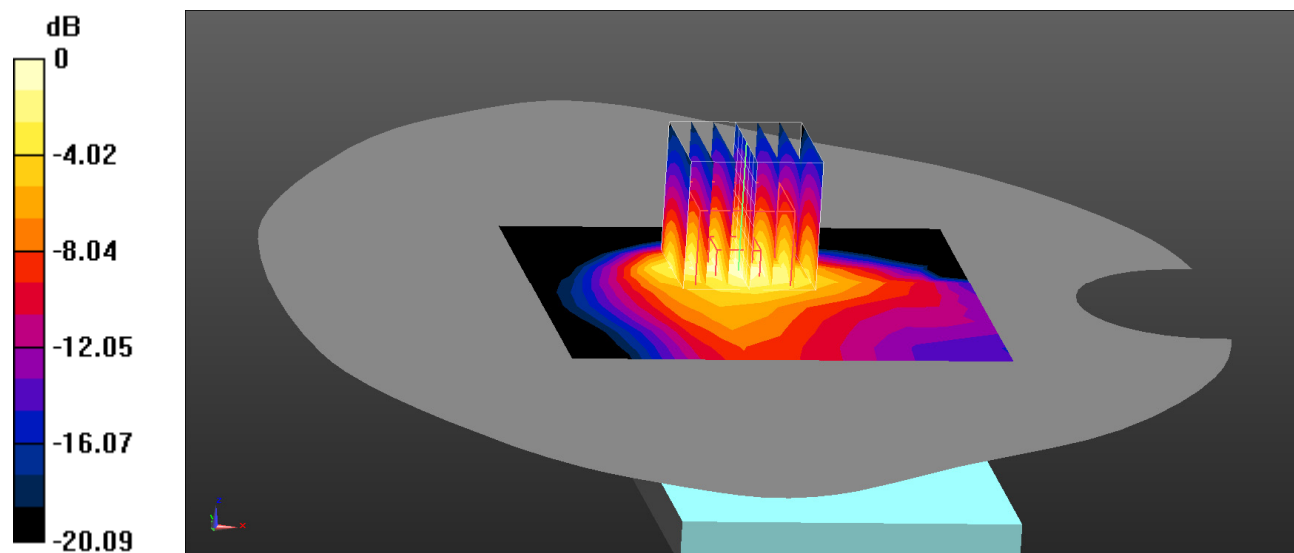

0 dB = 0.963 W/kg = -0.16 dBW/kg

Test Plot 30#

DUT: Smart phone; Type: G3 Mecha; Serial: 23N2_1

Communication System: UID 0, 2.4G DTS (0); Frequency: 2442 MHz;Duty Cycle: 1:1

Medium parameters used: $f = 2442 \text{ MHz}$; $\sigma = 1.845 \text{ S/m}$; $\epsilon_r = 40.128$; $\rho = 1000 \text{ kg/m}^3$

Phantom section: Flat Section

DASY5 Configuration:

- Probe: EX3DV4 - SN3701; ConvF(7.25, 7.25, 7.25) @ 2442 MHz;
- Sensor-Surface: 4mm (Mechanical Surface Detection)
- Electronics: DAE4 Sn1325; Calibrated: 8/29/2022
- Phantom: SAM-Twin V8.0 P1aP2a; Type: QD 000 P41 AA ; Serial: 1962
- Measurement SW: DASY52, Version 52.10 (2);

Limb Back/WLAN 802.11b Mid/Area Scan (11x11x1): Measurement grid: dx=10mm, dy=10mm

Maximum value of SAR (measured) = 2.55 W/kg

Limb Back/WLAN 802.11b Mid/Zoom Scan (7x7x7)/Cube 0: Measurement grid: dx=5mm, dy=5mm, dz=5mm

Reference Value = 36.04 V/m; Power Drift = 0.10 dB

Peak SAR (extrapolated) = 6.33 W/kg

SAR(1 g) = 2.53 W/kg; SAR(10 g) = 1.16 W/kg

Maximum value of SAR (measured) = 2.92 W/kg

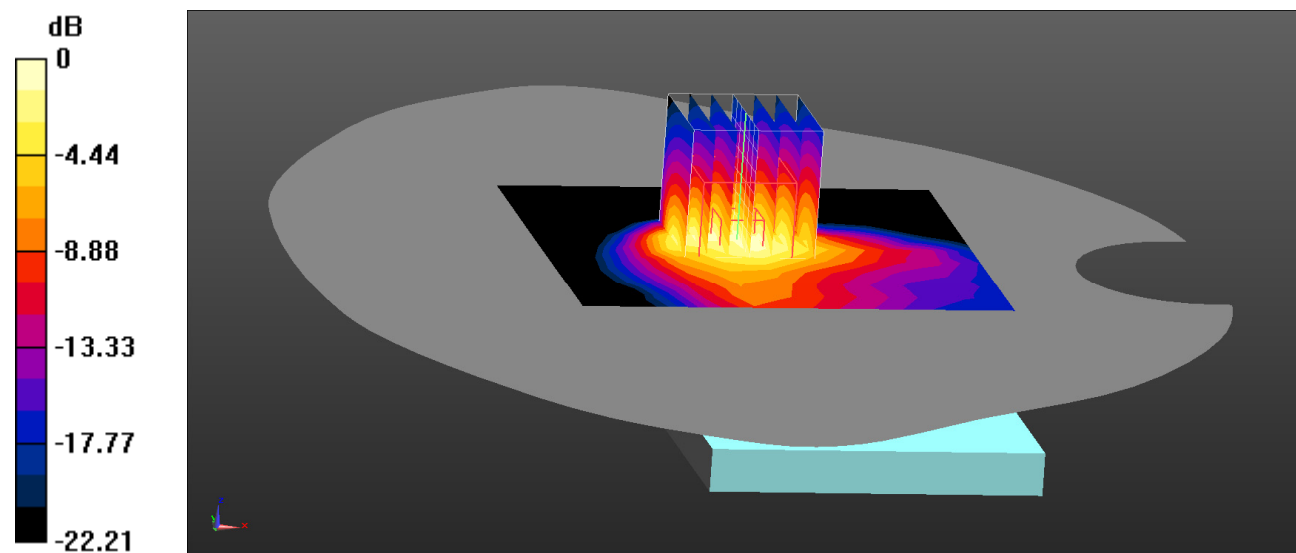

0 dB = 2.92 W/kg = 4.65 dBW/kg

Test Plot 31#**DUT: Smart phone; Type: G3 Mecha; Serial: 23N2_1**

Communication System: UID 0, 5.2G WiFi (0); Frequency: 5180 MHz;Duty Cycle: 1:1

Medium parameters used: $f = 5180 \text{ MHz}$; $\sigma = 4.727 \text{ S/m}$; $\epsilon_r = 36.65$; $\rho = 1000 \text{ kg/m}^3$

Phantom section: Left Section

DASY5 Configuration:

- Probe: EX3DV4 - SN3701; ConvF(5.3, 5.3, 5.3) @ 5180 MHz;
- Sensor-Surface: 2mm (Mechanical Surface Detection)
- Electronics: DAE4 Sn1325; Calibrated: 8/29/2022
- Phantom: SAM-Twin V8.0 P1aP2a; Type: QD 000 P41 AA ; Serial: 1962
- Measurement SW: DASY52, Version 52.10 (2);

Head Left Tilt/WLAN 5.2G 802.11a Low/Area Scan (11x11x1): Measurement grid: dx=10mm, dy=10mm

Maximum value of SAR (measured) = 0.325 W/kg

Head Left Tilt/WLAN 5.2G 802.11a Low/Zoom Scan (8x8x12)/Cube 0: Measurement grid: dx=4mm, dy=4mm, dz=2mm

Reference Value = 3.431 V/m; Power Drift = -0.01 dB

Peak SAR (extrapolated) = 0.872 W/kg

SAR(1 g) = 0.224 W/kg; SAR(10 g) = 0.081 W/kg

Maximum value of SAR (measured) = 0.421 W/kg

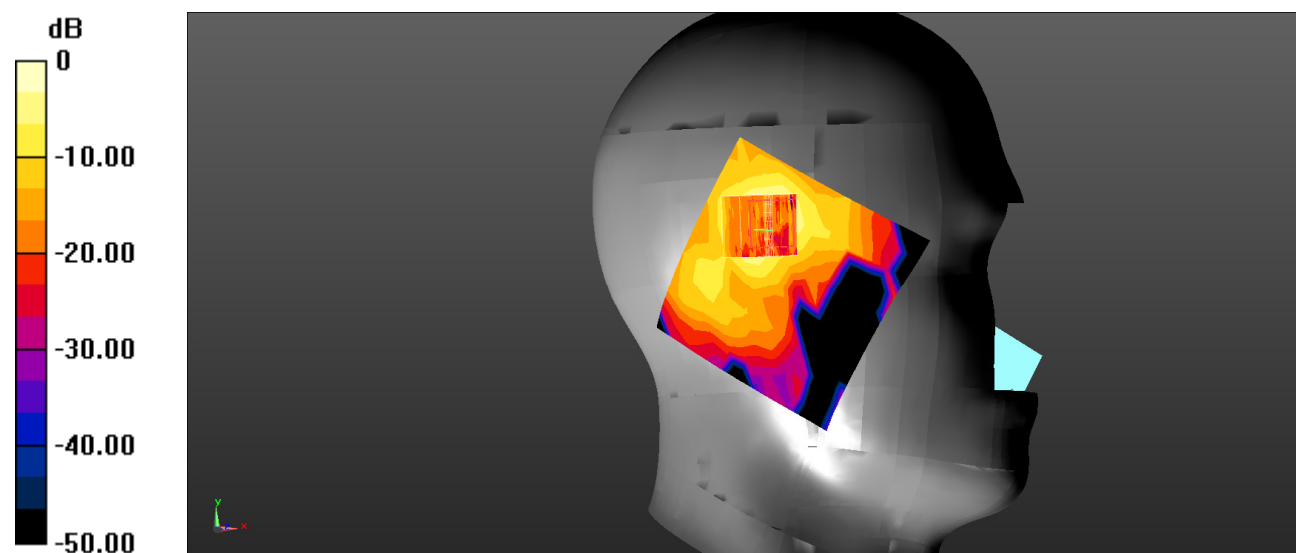

0 dB = 0.421 W/kg = -3.76 dBW/kg

Test Plot 32#

DUT: Smart phone; Type: G3 Mecha ; Serial: 23N2_1

Communication System: UID 0, 5.2G WiFi (0); Frequency: 5200 MHz;Duty Cycle: 1:1

Medium parameters used: $f = 5200 \text{ MHz}$; $\sigma = 4.7 \text{ S/m}$; $\epsilon_r = 36.783$; $\rho = 1000 \text{ kg/m}^3$

Phantom section: Flat Section

DASY5 Configuration:

- Probe: EX3DV4 - SN3701; ConvF(5.3, 5.3, 5.3) @ 5200 MHz;
- Sensor-Surface: 2mm (Mechanical Surface Detection)
- Electronics: DAE4 Sn1562; Calibrated: 3/26/2019
- Phantom: SAM-Twin V8.0 P1aP2a; Type: QD 000 P41 AA ; Serial: 1962
- Measurement SW: DASY52, Version 52.10 (2);

Body Back/WLAN 5.2G 802.11a Mid/Area Scan (11x11x1): Measurement grid: dx=10mm, dy=10mm

Maximum value of SAR (measured) = 0.380 W/kg

Body Back/WLAN 5.2G 802.11a Mid/Zoom Scan (8x8x12)/Cube 0: Measurement grid: dx=4mm, dy=4mm, dz=2mm

Reference Value = 2.846 V/m; Power Drift = 0.13 dB

Peak SAR (extrapolated) = 0.847 W/kg

SAR(1 g) = 0.216 W/kg; SAR(10 g) = 0.070 W/kg

Maximum value of SAR (measured) = 0.411 W/kg

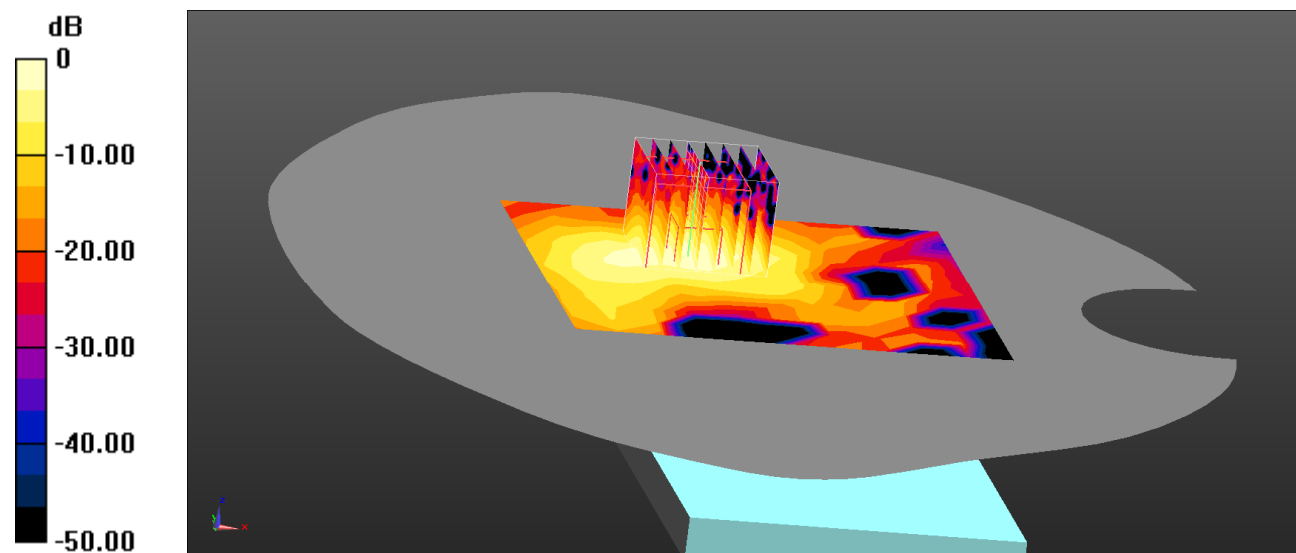

0 dB = 0.411 W/kg = -3.86 dBW/kg

Test Plot 33#

DUT: Smart phone; Type: G3 Mecha; Serial: 23N2_1

Communication System: UID 0, 5.2G WiFi (0); Frequency: 5200 MHz;Duty Cycle: 1:1

Medium parameters used: $f = 5200 \text{ MHz}$; $\sigma = 4.7 \text{ S/m}$; $\epsilon_r = 36.783$; $\rho = 1000 \text{ kg/m}^3$

Phantom section: Flat Section

DASY5 Configuration:

- Probe: EX3DV4 - SN3701; ConvF(5.3, 5.3, 5.3) @ 5200 MHz;
- Sensor-Surface: 2mm (Mechanical Surface Detection)
- Electronics: DAE4 Sn1325; Calibrated: 8/29/2022
- Phantom: SAM-Twin V8.0 P1aP2a; Type: QD 000 P41 AA ; Serial: 1962
- Measurement SW: DASY52, Version 52.10 (2);

Limb Back/WLAN 5.2G 802.11a Mid/Area Scan (11x11x1): Measurement grid: dx=10mm, dy=10mm

Maximum value of SAR (measured) = 0.949 W/kg

Limb Back/WLAN 5.2G 802.11a Mid/Zoom Scan (8x8x12)/Cube 0: Measurement grid: dx=4mm, dy=4mm, dz=2mm

Reference Value = 4.261 V/m; Power Drift = 0.04 dB

Peak SAR (extrapolated) = 2.19 W/kg

SAR(1 g) = 0.510 W/kg; SAR(10 g) = 0.165 W/kg

Maximum value of SAR (measured) = 0.955 W/kg

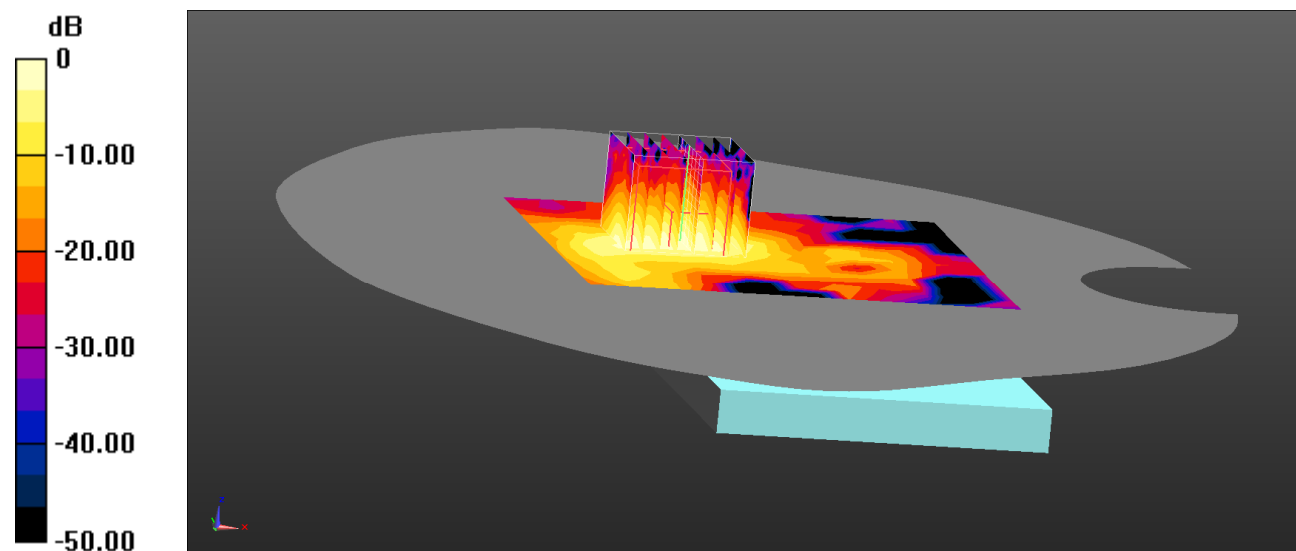

0 dB = 0.955 W/kg = -0.20 dBW/kg

Test Plot 34#

DUT: Smart phone; Type: G3 Mecha; Serial: 23N2_1

Communication System: UID 0, 5.8G Wi-Fi (0); Frequency: 5745 MHz;Duty Cycle: 1:1

Medium parameters used: $f = 5745 \text{ MHz}$; $\sigma = 5.229 \text{ S/m}$; $\epsilon_r = 36.173$; $\rho = 1000 \text{ kg/m}^3$

Phantom section: Right Section

DASY5 Configuration:

- Probe: EX3DV4 - SN3701; ConvF(4.82, 4.82, 4.82) @ 5745 MHz;
- Sensor-Surface: 2mm (Mechanical Surface Detection)
- Electronics: DAE4 Sn1562; Calibrated: 3/26/2019
- Phantom: SAM-Twin V8.0 P1aP2a; Type: QD 000 P41 AA ; Serial: 1962
- Measurement SW: DASY52, Version 52.10 (2);

Head Right Tilt/WLAN 5.8G 802.11a Low/Area Scan (11x11x1): Measurement grid: dx=10mm, dy=10mm

Maximum value of SAR (measured) = 1.39 W/kg

Head Right Tilt/WLAN 5.8G 802.11a Low/Zoom Scan (8x8x12)/Cube 0: Measurement grid: dx=4mm, dy=4mm, dz=2mm

Reference Value = 6.385 V/m; Power Drift = 0.19 dB

Peak SAR (extrapolated) = 3.14 W/kg

SAR(1 g) = 0.756 W/kg; SAR(10 g) = 0.247 W/kg

Maximum value of SAR (measured) = 1.54 W/kg

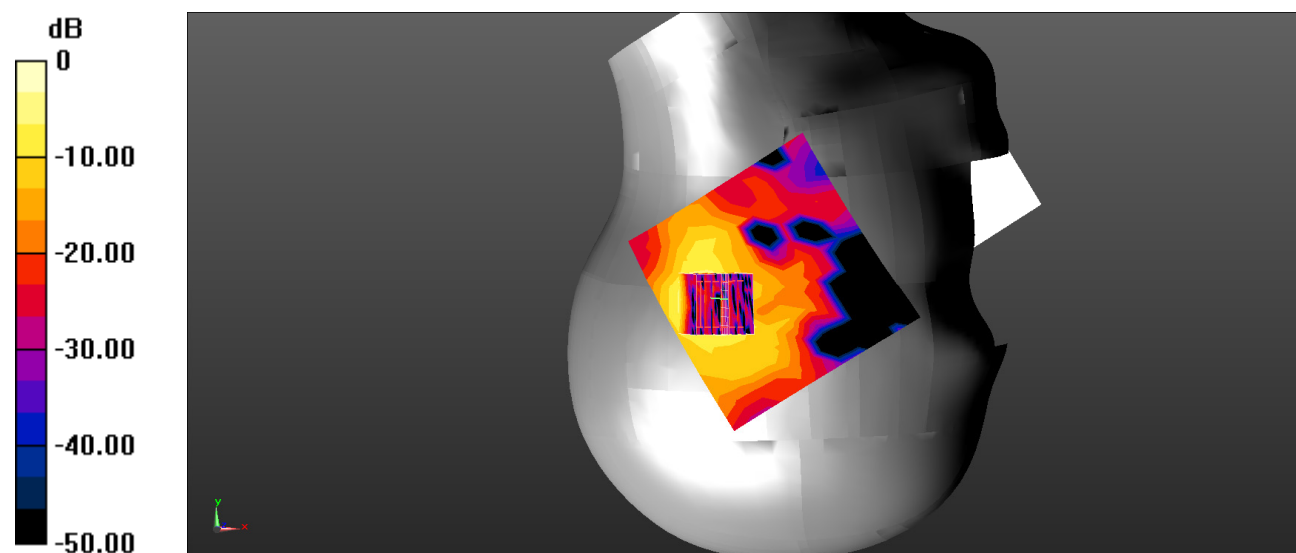

0 dB = 1.54 W/kg = 1.88 dBW/kg

Test Plot 35#

DUT: Smart phone; Type: G3 Mecha ; Serial: 23N2_1

Communication System: UID 0, 5.8G Wi-Fi (0); Frequency: 5785 MHz;Duty Cycle: 1:1

Medium parameters used: $f = 5785 \text{ MHz}$; $\sigma = 5.27 \text{ S/m}$; $\epsilon_r = 36.222$; $\rho = 1000 \text{ kg/m}^3$

Phantom section: Flat Section

DASY5 Configuration:

- Probe: EX3DV4 - SN3701; ConvF(4.82, 4.82, 4.82) @ 5785 MHz;
- Sensor-Surface: 2mm (Mechanical Surface Detection)
- Electronics: DAE4 Sn1562; Calibrated: 3/26/2019
- Phantom: SAM-Twin V8.0 P1aP2a; Type: QD 000 P41 AA ; Serial: 1962
- Measurement SW: DASY52, Version 52.10 (2);

Body Back/WLAN 5.8G 802.11a Mid/Area Scan (11x11x1): Measurement grid: dx=10mm, dy=10mm

Maximum value of SAR (measured) = 0.837 W/kg

Body Back/WLAN 5.8G 802.11a Mid/Zoom Scan (8x8x12)/Cube 0: Measurement grid: dx=4mm, dy=4mm, dz=2mm

Reference Value = 7.406 V/m; Power Drift = 0.11 dB

Peak SAR (extrapolated) = 1.90 W/kg

SAR(1 g) = 0.479 W/kg; SAR(10 g) = 0.187 W/kg

Maximum value of SAR (measured) = 0.891 W/kg

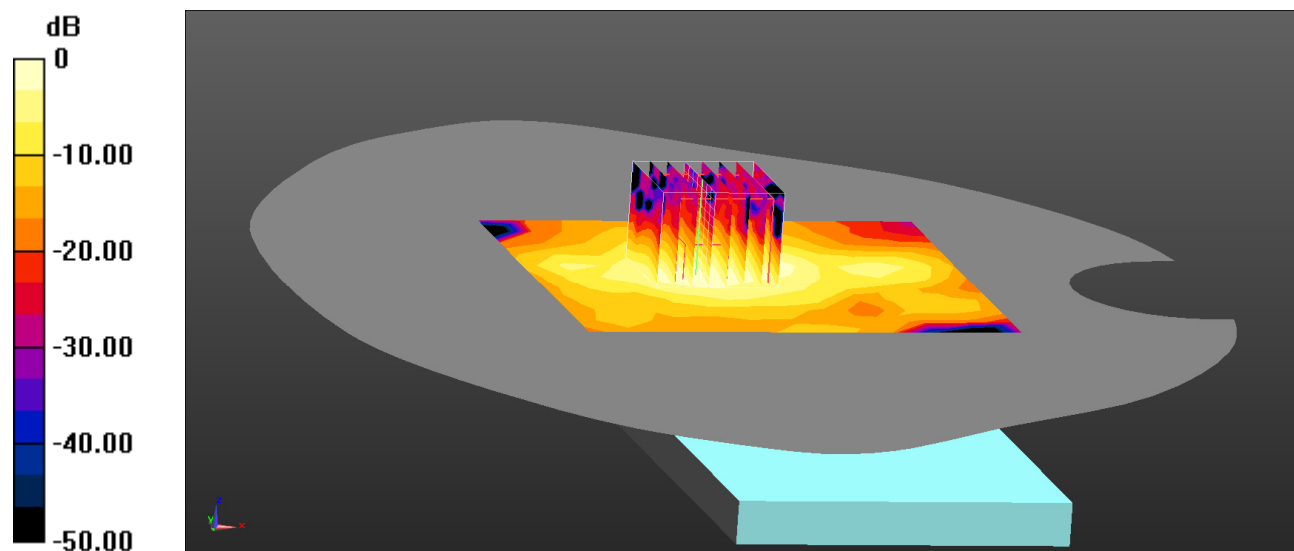

0 dB = 0.891 W/kg = -0.50 dBW/kg

Test Plot 36#

DUT: Smart phone; Type: G3 Mecha; Serial: 23N2_1

Communication System: UID 0, 5.8G Wi-Fi (0); Frequency: 5785 MHz;Duty Cycle: 1:1

Medium parameters used: $f = 5785 \text{ MHz}$; $\sigma = 5.27 \text{ S/m}$; $\epsilon_r = 36.222$; $\rho = 1000 \text{ kg/m}^3$

Phantom section: Flat Section

DASY5 Configuration:

- Probe: EX3DV4 - SN3701; ConvF(4.82, 4.82, 4.82) @ 5785 MHz;
- Sensor-Surface: 2mm (Mechanical Surface Detection)
- Electronics: DAE4 Sn1325; Calibrated: 8/29/2022
- Phantom: SAM-Twin V8.0 P1aP2a; Type: QD 000 P41 AA ; Serial: 1962
- Measurement SW: DASY52, Version 52.10 (2);

Limb Back/WLAN 5.8G 802.11a Mid/Area Scan (11x11x1): Measurement grid: dx=10mm, dy=10mm

Maximum value of SAR (measured) = 1.54 W/kg

Limb Back/WLAN 5.8G 802.11a Mid/Zoom Scan (8x8x12)/Cube 0: Measurement grid: dx=4mm, dy=4mm, dz=2mm

Reference Value = 8.924 V/m; Power Drift = 0.16 dB

Peak SAR (extrapolated) = 3.17 W/kg

SAR(1 g) = 0.742 W/kg; SAR(10 g) = 0.258 W/kg

Maximum value of SAR (measured) = 1.48 W/kg

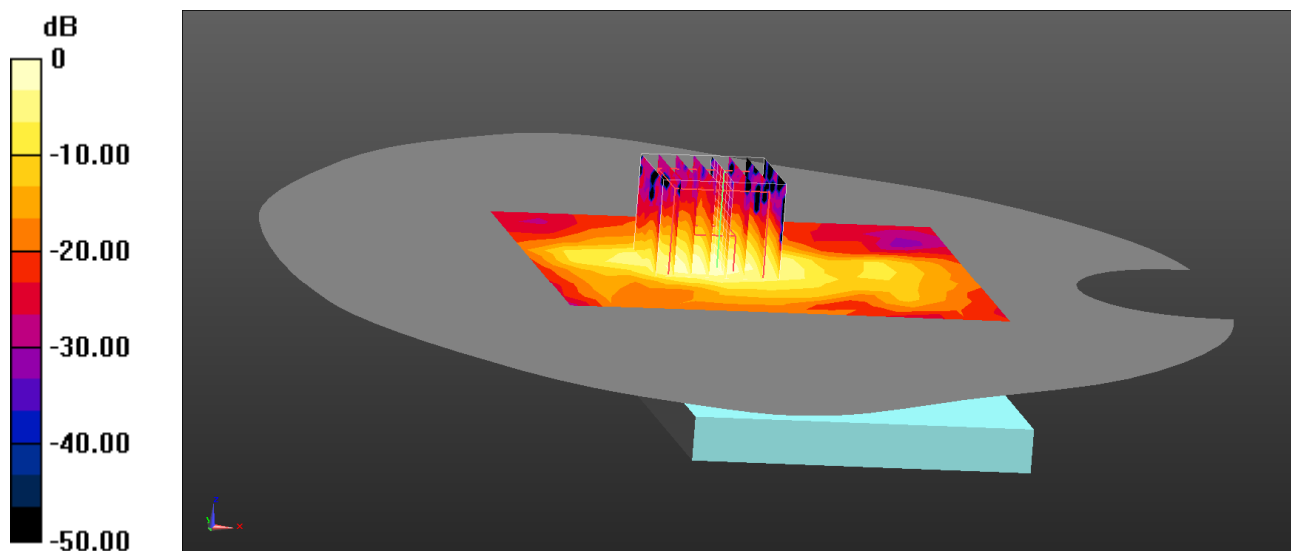

0 dB = 1.48 W/kg = 1.70 dBW/kg

APPENDIX A MEASUREMENT UNCERTAINTY

The uncertainty budget has been determined for the measurement system and is given in the following Table.

Measurement uncertainty evaluation for EN62209-1:2016 SAR test

Source of uncertainty	Tolerance/ uncertainty ± %	Probability distribution	Divisor	ci (1 g)	ci (10 g)	Standard uncertainty ± %, (1 g)	Standard uncertainty ± %, (10 g)
Measurement system							
System calibration	6.55	N	1	0	0	6.55	6.55
Isotropy	4.7	R	$\sqrt{3}$	1	1	2.7	2.7
Boundary effect	9.6	R	$\sqrt{3}$	1	1	0.0	0.0
Linearity	1.0	R	$\sqrt{3}$	1	1	0.6	0.6
Linearity	4.7	R	$\sqrt{3}$	1	1	2.7	2.7
System detection limits	1.0	R	$\sqrt{3}$	1	1	0.6	0.6
Modulation response	0.3	R	1	0	0	0.3	0.3
Readout electronics	0.0	N	$\sqrt{3}$	0	0	0.0	0.0
Response time	0.0	R	$\sqrt{3}$	1	1	0.0	0.0
Integration time	1.0	R	$\sqrt{3}$	1	1	0.6	0.6
RF ambient conditions – noise	1.0	R	$\sqrt{3}$	0	0	0.6	0.6
RF ambient conditions – reflections	0.8	R	$\sqrt{3}$	1	1	0.5	0.5
Sensor positioning uncertainty	6.7	R	$\sqrt{3}$	1	1	3.9	3.9
Sensor location sensitivity	2.0	R	$\sqrt{3}$	1	1	1.2	1.2
Spatial resolution, x-direction	4.0	R	$\sqrt{3}$	1	1	0.0	0.0
Spatial resolution, y-direction	3.0	R	$\sqrt{3}$	1	1	0.0	0.0
Post-processing of measurement data	2.0	R	$\sqrt{3}$	1	1	1.2	1.2
Mutual sensor coupling	0.6	R	$\sqrt{3}$	1	1	0.0	0.0
Sensor coupling with DUT	1.5	R	$\sqrt{3}$	1	1	0.0	0.0
Measurement system immunity	2.0	R	$\sqrt{3}$	1	1	0.0	0.0
Test sample related							
Test sample positioning	2.8	N	1	1	1	2.8	2.8
Device holder uncertainty	6.3	N	1	1	1	6.3	6.3
Output power variation – SAR drift measurement	4.5	R	$\sqrt{3}$	1	1	2.6	2.6
SAR scaling	5.0	R	$\sqrt{3}$	0	0	2.9	2.9

Phantom and Tissue Parameters							
Phantom shell uncertainty -shape thickness and permittivity	4.0	R	$\sqrt{3}$	1	1	2.3	2.3
Deviations in phantom shape	5.0	R	$\sqrt{3}$	1	1	1.8	1.2
Uncertainty in SAR correction for deviations in permittivity and conductivity	2.5	N	1	0	0	1.6	1.1
Liquid conductivity measurement	2.5	N	1	0	0	1.6	1.1
Liquid permittivity measurement	2.5	N	1	0	0	1.5	1.2
Liquid conductivity – temperature uncertainty	1.7	R	$\sqrt{3}$	0	0	0.8	0.7
Liquid permittivity – temperature uncertainty	0.3	R	$\sqrt{3}$	0	0	0.0	0.0
Spatial variation in conductivity	2.0	R	$\sqrt{3}$	0.78	0.71	1.0	1.0
Spatial variation in permittivity	2.0	R	$\sqrt{3}$	0.23	0.26	1.0	1.0
Combined standard uncertainty		RSS				12.2	12.0
Expanded uncertainty (95 % CONFIDENCE INTERVAL)		$k = 2$				24.4	24.0

Measurement uncertainty evaluation for EN62209-2:2010 SAR test

Source of uncertainty	Tolerance/ uncertainty ± %	Probability distribution	Divisor	ci (1 g)	ci (10 g)	Standard uncertainty ± %, (1 g)	Standard uncertainty ± %, (10 g)
Measurement system							
Probe calibration	6.55	N	1	1	1	6.6	6.6
Axial Isotropy	4.7	R	√3	1	1	2.7	2.7
Hemispherical Isotropy	9.6	R	√3	0	0	0.0	0.0
Linearity	4.7	R	√3	1	1	2.7	2.7
Modulation Response	0.0	R	√3	1	1	0.0	0.0
Detection limits	1.0	R	√3	1	1	0.6	0.6
Boundary effect	1.0	R	√3	1	1	0.6	0.6
Readout electronics	0.3	N	1	1	1	0.3	0.3
Response time	0.0	R	√3	1	1	0.0	0.0
Integration time	0.0	R	√3	1	1	0.0	0.0
RF ambient conditions – noise	1.0	R	√3	1	1	0.6	0.6
RF ambient conditions–reflections	1.0	R	√3	1	1	0.6	0.6
Probe positioner mech. Restrictions	0.8	R	√3	1	1	0.5	0.5
Probe positioning with respect to phantom shell	6.7	R	√3	1	1	3.9	3.9
Post-processing	2.0	R	√3	1	1	1.2	1.2
Test sample related							
Device holder Uncertainty	6.3	N	1	1	1	6.3	6.3
Test sample positioning	2.8	N	1	1	1	2.8	2.8
Power scaling	4.5	R	√3	1	1	2.6	2.6
Drift of output power	5.0	R	√3	1	1	2.9	2.9
Phantom and set-up							
Phantom uncertainty (shape and thickness tolerances)	4.0	R	√3	1	1	2.3	2.3
Algorithm for correcting SAR for deviations in permittivity and conductivity	1.9	N	1	1	0.84	1.1	0.9
Liquid conductivity (meas.)	2.5	N	1	0.64	0.43	1.6	1.1
Liquid permittivity (meas.)	2.5	N	1	0.6	0.49	1.5	1.2
Temp. unc. - Conductivity	1.7	R	√3	0.78	0.71	0.8	0.7
Temp. unc. - Permittivity	0.3	R	√3	0.23	0.26	0.0	0.0
Combined standard uncertainty		RSS				12.2	12.1
Expanded uncertainty 95 % confidence interval)						24.5	24.2

APPENDIX B PROBE CALIBRATION CERTIFICATES



Add: No.52 Hua YuanBei Road, Haidian District, Beijing, 100191, China
 Tel: +86-10-62304633-2117
 E-mail: emf@caict.ac.cn http://www.caict.ac.cn



Client **ATC**

Certificate No: **Z23-60088**

CALIBRATION CERTIFICATE			
Object	EX3DV4 - SN : 3701		
Calibration Procedure(s)	FF-Z11-004-02 Calibration Procedures for Dosimetric E-field Probes		
Calibration date:	March 15, 2023		
<p>This calibration Certificate documents the traceability to national standards, which realize the physical units of measurements(SI). The measurements and the uncertainties with confidence probability are given on the following pages and are part of the certificate.</p> <p>All calibrations have been conducted in the closed laboratory facility: environment temperature(22±3)°C and humidity<70%.</p> <p>Calibration Equipment used (M&TE critical for calibration)</p>			
Primary Standards	ID #	Cal Date(Calibrated by, Certificate No.)	Scheduled Calibration
Power Meter NRP2	101919	14-Jun-22(CTTL, No.J22X04181)	Jun-23
Power sensor NRP-Z91	101547	14-Jun-22(CTTL, No.J22X04181)	Jun-23
Power sensor NRP-Z91	101548	14-Jun-22(CTTL, No.J22X04181)	Jun-23
Reference 10dBAttenuator	18N50W-10dB	19-Jan-23(CTTL, No.J23X00212)	Jan-25
Reference 20dBAttenuator	18N50W-20dB	19-Jan-23(CTTL, No.J23X00211)	Jan-25
Reference Probe EX3DV4	SN 3846	20-May-22(SPEAG, No.EX3-3846_May22)	May-23
DAE4	SN 1555	25-Aug-22(SPEAG, No.DAE4-1555_Aug22)	Aug-23
Secondary Standards	ID #	Cal Date(Calibrated by, Certificate No.)	Scheduled Calibration
SignalGenerator MG3700A	6201052605	14-Jun-22(CTTL, No.J22X04182)	Jun-23
Network Analyzer E5071C	MY46110673	10-Jan-23(CTTL, No.J23X00104)	Jan-24
	Name	Function	Signature
Calibrated by:	Yu Zongying	SAR Test Engineer	
Reviewed by:	Lin Hao	SAR Test Engineer	
Approved by:	Qi Dianyuan	SAR Project Leader	
Issued: March 19, 2023			
This calibration certificate shall not be reproduced except in full without written approval of the laboratory.			



Add: No.52 HuaYuanBei Road, Haidian District, Beijing, 100191, China
 Tel: +86-10-62304633-2117
 E-mail: emf@caict.ac.cn http://www.caict.ac.cn

Glossary:

TSL	tissue simulating liquid
NORM _{x,y,z}	sensitivity in free space
ConvF	sensitivity in TSL / NORM _{x,y,z}
DCP	diode compression point
CF	crest factor (1/duty_cycle) of the RF signal
A,B,C,D	modulation dependent linearization parameters
Polarization Φ	Φ rotation around probe axis
Polarization θ	θ rotation around an axis that is in the plane normal to probe axis (at measurement center), $\theta=0$ is normal to probe axis

Connector Angle information used in DASY system to align probe sensor X to the robot coordinate system

Calibration is Performed According to the Following Standards:

- IEEE Std 1528-2013, "IEEE Recommended Practice for Determining the Peak Spatial-Averaged Specific Absorption Rate (SAR) in the Human Head from Wireless Communications Devices: Measurement Techniques", June 2013
- IEC 62209-1, "Measurement procedure for the assessment of Specific Absorption Rate (SAR) from hand-held and body-mounted devices used next to the ear (frequency range of 300 MHz to 6 GHz)", July 2016
- IEC 62209-2, "Procedure to determine the Specific Absorption Rate (SAR) for wireless communication devices used in close proximity to the human body (frequency range of 30 MHz to 6 GHz)", March 2010
- KDB 865664, "SAR Measurement Requirements for 100 MHz to 6 GHz"

Methods Applied and Interpretation of Parameters:

- NORM_{x,y,z}:** Assessed for E-field polarization $\theta=0$ ($f \leq 900\text{MHz}$ in TEM-cell; $f > 1800\text{MHz}$: waveguide). NORM_{x,y,z} are only intermediate values, i.e., the uncertainties of NORM_{x,y,z} does not effect the E^2 -field uncertainty inside TSL (see below ConvF).
- NORM(f)_{x,y,z} = NORM_{x,y,z}* frequency_response** (see Frequency Response Chart). This linearization is implemented in DASY4 software versions later than 4.2. The uncertainty of the frequency response is included in the stated uncertainty of ConvF.
- DCP_{x,y,z}:** DCP are numerical linearization parameters assessed based on the data of power sweep (no uncertainty required). DCP does not depend on frequency nor media.
- PAR:** PAR is the Peak to Average Ratio that is not calibrated but determined based on the signal characteristics.
- A_{x,y,z}; B_{x,y,z}; C_{x,y,z}; VR_{x,y,z}; A,B,C** are numerical linearization parameters assessed based on the data of power sweep for specific modulation signal. The parameters do not depend on frequency nor media. VR is the maximum calibration range expressed in RMS voltage across the diode.
- ConvF and Boundary Effect Parameters:** Assessed in flat phantom using E-field (or Temperature Transfer Standard for $f \leq 800\text{MHz}$) and inside waveguide using analytical field distributions based on power measurements for $f > 800\text{MHz}$. The same setups are used for assessment of the parameters applied for boundary compensation (alpha, depth) of which typical uncertainty valued are given. These parameters are used in DASY4 software to improve probe accuracy close to the boundary. The sensitivity in TSL corresponds to NORM_{x,y,z}* ConvF whereby the uncertainty corresponds to that given for ConvF. A frequency dependent ConvF is used in DASY version 4.4 and higher which allows extending the validity from $\pm 50\text{MHz}$ to $\pm 100\text{MHz}$.
- Spherical isotropy (3D deviation from isotropy):** in a field of low gradients realized using a flat phantom exposed by a patch antenna.
- Sensor Offset:** The sensor offset corresponds to the offset of virtual measurement center from the probe tip (on probe axis). No tolerance required.
- Connector Angle:** The angle is assessed using the information gained by determining the NORM_x (no uncertainty required).

Certificate No:Z23-60088

Page 2 of 9



Add: No.52 HuaYuanBei Road, Haidian District, Beijing, 100191, China
 Tel: +86-10-62304633-2117
 E-mail: emf@caict.ac.cn http://www.caict.ac.cn

DASY/EASY – Parameters of Probe: EX3DV4 – SN:3701

Basic Calibration Parameters

	Sensor X	Sensor Y	Sensor Z	Unc (k=2)
Norm($\mu\text{V}/(\text{V}/\text{m})^2$) ^A	0.46	0.47	0.47	±10.0%
DCP(mV) ^B	110.6	109.9	109.3	

Modulation Calibration Parameters

UID	Communication System Name		A dB	B dB- μV	C	D dB	VR mV	Unc ^E (k=2)
0	CW	X	0.0	0.0	1.0	0.00	162.2	±4.6%
		Y	0.0	0.0	1.0		163.5	
		Z	0.0	0.0	1.0		166.6	

The reported uncertainty of measurement is stated as the standard uncertainty of Measurement multiplied by the coverage factor $k=2$, which for a normal distribution Corresponds to a coverage probability of approximately 95%.

^A The uncertainties of Norm X, Y, Z do not affect the E²-field uncertainty inside TSL (see Page 4).

^B Numerical linearization parameter: uncertainty not required.

^E Uncertainty is determined using the max. deviation from linear response applying rectangular distribution and is expressed for the square of the field value.



Add: No.52 HuaYuanBei Road, Haidian District, Beijing, 100191, China
 Tel: +86-10-62304633-2117
 E-mail: cmf@caict.ac.cn http://www.caict.ac.cn

DASY/EASY – Parameters of Probe: EX3DV4 – SN:3701

Calibration Parameter Determined in Head Tissue Simulating Media

f [MHz] ^C	Relative Permittivity ^F	Conductivity (S/m) ^F	ConvF X	ConvF Y	ConvF Z	Alpha ^G	Depth ^G (mm)	Unct. (k=2)
750	41.9	0.89	9.71	9.71	9.71	0.12	1.15	±12.7%
900	41.5	0.97	9.25	9.25	9.25	0.14	1.45	±12.7%
1750	40.1	1.37	7.97	7.97	7.97	0.27	0.98	±12.7%
1900	40.0	1.40	7.65	7.65	7.65	0.29	0.95	±12.7%
2300	39.5	1.67	7.50	7.50	7.50	0.50	0.71	±12.7%
2450	39.2	1.80	7.25	7.25	7.25	0.49	0.73	±12.7%
2600	39.0	1.96	7.03	7.03	7.03	0.43	0.84	±12.7%
5250	35.9	4.71	5.30	5.30	5.30	0.40	1.45	±13.9%
5500	35.6	4.96	4.80	4.80	4.80	0.45	1.40	±13.9%
5750	35.4	5.22	4.82	4.82	4.82	0.45	1.40	±13.9%

^C Frequency validity above 300 MHz of ±100MHz only applies for DASY v4.4 and higher (Page 2), else it is restricted to ±50MHz. The uncertainty is the RSS of ConvF uncertainty at calibration frequency and the uncertainty for the indicated frequency band. Frequency validity below 300 MHz is ± 10, 25, 40, 50 and 70 MHz for ConvF assessments at 30, 64, 128, 150 and 220 MHz respectively. Above 5 GHz frequency validity can be extended to ± 110 MHz.

^F At frequency up to 6 GHz, the validity of tissue parameters (ε and σ) can be relaxed to ±10% if liquid compensation formula is applied to measured SAR values. The uncertainty is the RSS of the ConvF uncertainty for indicated target tissue parameters.

^G Alpha/Depth are determined during calibration. SPEAG warrants that the remaining deviation due to the boundary effect after compensation is always less than ± 1% for frequencies below 3 GHz and below ± 2% for the frequencies between 3-6 GHz at any distance larger than half the probe tip diameter from the boundary.



Add: No.52 HuaYuanBei Road, Haidian District, Beijing, 100191, China
Tel: +86-10-62304633-2117
E-mail: emf@caict.ac.cn <http://www.caict.ac.cn>

Frequency Response of E-Field (TEM-Cell: ifi110 EXX, Waveguide: R22)

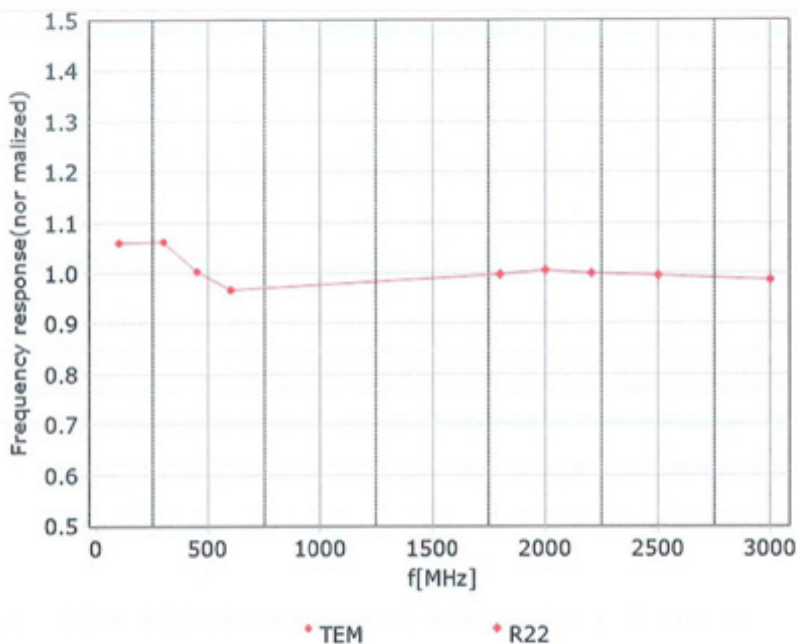

Uncertainty of Frequency Response of E-field: $\pm 7.4\%$ ($k=2$)



Add: No.52 HuaYuanBei Road, Haidian District, Beijing, 100191, China
Tel: +86-10-62304633-2117
E-mail: emf@caict.ac.cn http://www.caict.ac.cn

Receiving Pattern (Φ), $\theta=0^\circ$

f=600 MHz, TEM

f=1800 MHz, R22

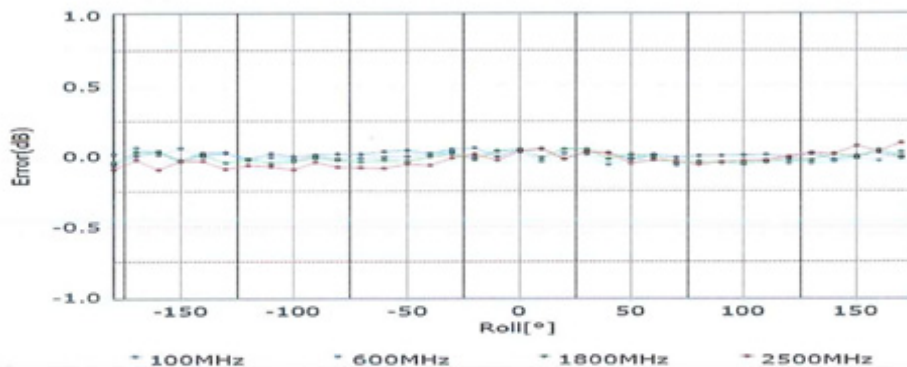
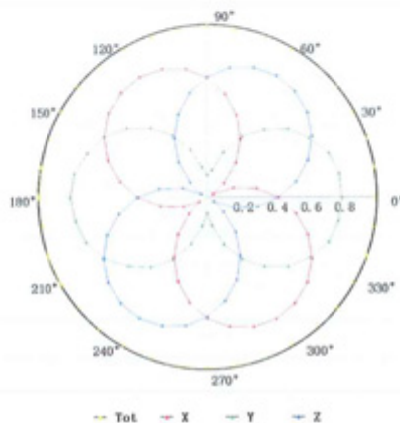
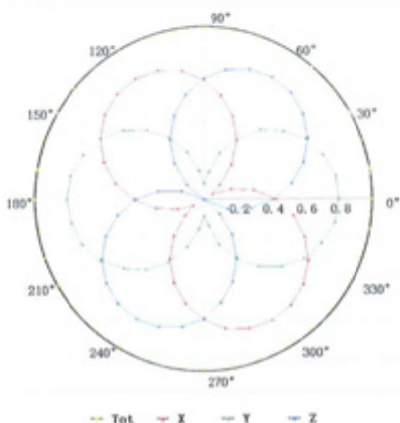

Uncertainty of Axial Isotropy Assessment: $\pm 1.2\%$ ($k=2$)



Add: No.52 HuaYuanBei Road, Haidian District, Beijing, 100191, China
 Tel: +86-10-62304633-2117
 E-mail: emf@caict.ac.cn http://www.caict.ac.cn

Dynamic Range f(SAR_{head}) (TEM cell, f = 900 MHz)

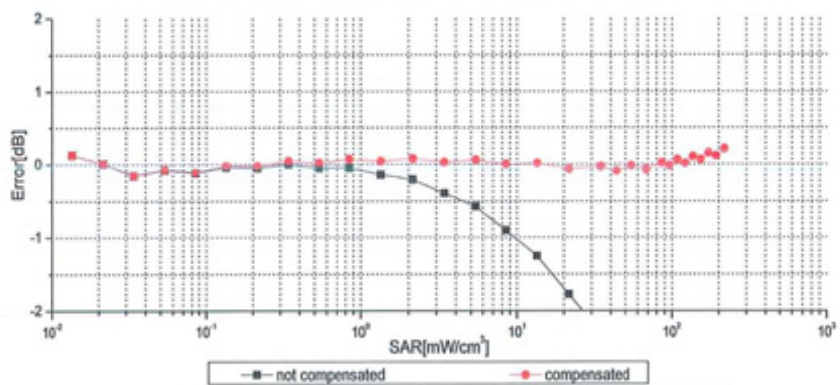
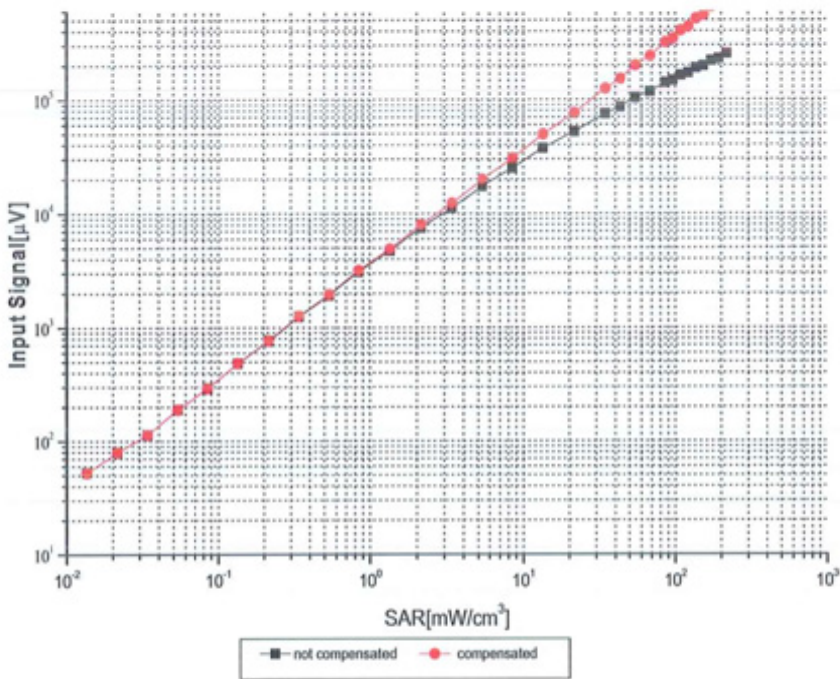

Uncertainty of Linearity Assessment: ±0.9% (k=2)



Add: No.52 HuaYuanBei Road, Haidian District, Beijing, 100191, China
Tel: +86-10-62304633-2117
E-mail: emf@caict.ac.cn http://www.caict.ac.cn

Conversion Factor Assessment

f=750 MHz,WGLS R9(H_convF)

f=1750 MHz,WGLS R22(H_convF)

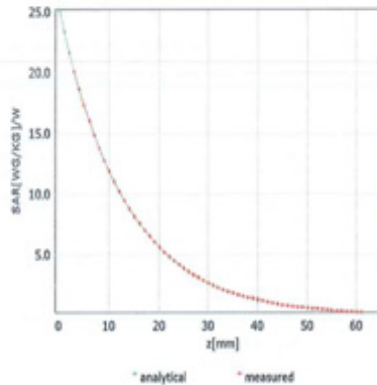
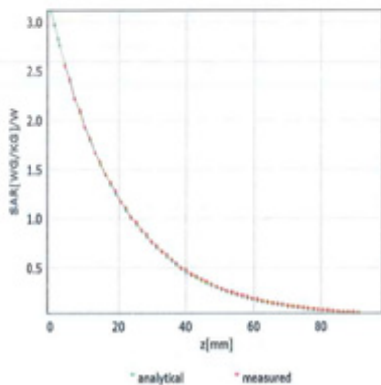

Deviation from Isotropy in Liquid

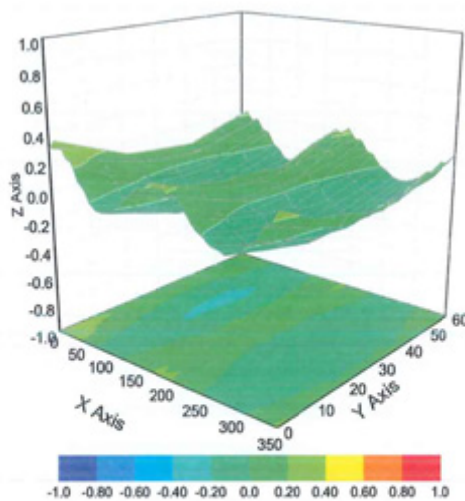

Uncertainty of Spherical Isotropy Assessment: ±3.2% (k=2)



Add: No.52 HuaYuanBei Road, Haidian District, Beijing, 100191, China
 Tel: +86-10-62304633-2117
 E-mail: emf@caict.ac.cn <http://www.caict.ac.cn>

DASY/EASY – Parameters of Probe: EX3DV4 – SN:3701

Other Probe Parameters

Sensor Arrangement	Triangular
Connector Angle (°)	44.6
Mechanical Surface Detection Mode	enabled
Optical Surface Detection Mode	disable
Probe Overall Length	337mm
Probe Body Diameter	10mm
Tip Length	9mm
Tip Diameter	2.5mm
Probe Tip to Sensor X Calibration Point	1mm
Probe Tip to Sensor Y Calibration Point	1mm
Probe Tip to Sensor Z Calibration Point	1mm
Recommended Measurement Distance from Surface	1.4mm

APPENDIX C DIPOLE CALIBRATION CERTIFICATES

**Calibration Laboratory of
Schmid & Partner
Engineering AG**
Zeughausstrasse 43, 8004 Zurich, Switzerland



S Schweizerischer Kalibrierdienst
C Service suisse d'étalonnage
S Servizio svizzero di taratura
S Swiss Calibration Service

Accreditation No.: **SCS 0108**

Accredited by the Swiss Accreditation Service (SAS)
The Swiss Accreditation Service is one of the signatories to the EA
Multilateral Agreement for the recognition of calibration certificates

Client **BACL USA**
Sunnyvale, USA

Certificate No. **D750V3-1229_Mar23**

CALIBRATION CERTIFICATE			
Object	D750V3 - SN:1229		
Calibration procedure(s)	QA CAL-05.v12 Calibration Procedure for SAR Validation Sources between 0.7-3 GHz		
Calibration date:	March 24, 2023		
<p>This calibration certificate documents the traceability to national standards, which realize the physical units of measurements (SI). The measurements and the uncertainties with confidence probability are given on the following pages and are part of the certificate.</p> <p>All calibrations have been conducted in the closed laboratory facility: environment temperature (22 ± 3)°C and humidity < 70%.</p> <p>Calibration Equipment used (M&TE critical for calibration)</p>			
Primary Standards	ID #	Cal Date (Certificate No.)	Scheduled Calibration
Power meter NRP	SN: 104778	04-Apr-22 (No. 217-03525/03524)	Apr-23
Power sensor NRP-Z91	SN: 103244	04-Apr-22 (No. 217-03524)	Apr-23
Power sensor NRP-Z91	SN: 103245	04-Apr-22 (No. 217-03525)	Apr-23
Reference 20 dB Attenuator	SN: BH9394 (20k)	04-Apr-22 (No. 217-03527)	Apr-23
Type-N mismatch combination	SN: 310982 / 06327	04-Apr-22 (No. 217-03528)	Apr-23
Reference Probe EX3DV4	SN: 7349	10-Jan-23 (No. EX3-7349_Jan23)	Jan-24
DAE4	SN: 601	19-Dec-22 (No. DAE4-601_Dec22)	Dec-23
Secondary Standards	ID #	Check Date (in house)	Scheduled Check
Power meter E4419B	SN: GB39512475	30-Oct-14 (in house check Oct-22)	In house check: Oct-24
Power sensor HP 8481A	SN: US37292783	07-Oct-15 (in house check Oct-22)	In house check: Oct-24
Power sensor HP 8481A	SN: MY41093315	07-Oct-15 (in house check Oct-22)	In house check: Oct-24
RF generator R&S SMT-06	SN: 100972	15-Jun-15 (in house check Oct-22)	In house check: Oct-24
Network Analyzer Agilent E8358A	SN: US41080477	31-Mar-14 (in house check Oct-22)	In house check: Oct-24
Calibrated by:	Name Michael Weber	Function Laboratory Technician	Signature
Approved by:	Name Sven Kühn	Technical Manager	Signature
			Issued: March 24, 2023
This calibration certificate shall not be reproduced except in full without written approval of the laboratory.			

**Calibration Laboratory of
Schmid & Partner
Engineering AG**
Zeughausstrasse 43, 8004 Zurich, Switzerland



S Schweizerischer Kalibrierdienst
C Service suisse d'étalonnage
S Servizio svizzero di taratura
S Swiss Calibration Service

Accredited by the Swiss Accreditation Service (SAS)
The Swiss Accreditation Service is one of the signatories to the EA
Multilateral Agreement for the recognition of calibration certificates

Accreditation No.: **SCS 0108**

Glossary:

TSL tissue simulating liquid
ConvF sensitivity in TSL / NORM x,y,z
N/A not applicable or not measured

Calibration is Performed According to the Following Standards:

- a) IEC/IEEE 62209-1528, "Measurement Procedure For The Assessment Of Specific Absorption Rate Of Human Exposure To Radio Frequency Fields From Hand-Held And Body-Worn Wireless Communication Devices - Part 1528: Human Models, Instrumentation And Procedures (Frequency Range of 4 MHz to 10 GHz)", October 2020.
- b) KDB 865664, "SAR Measurement Requirements for 100 MHz to 6 GHz"

Additional Documentation:

- c) DASY System Handbook

Methods Applied and Interpretation of Parameters:

- *Measurement Conditions:* Further details are available from the Validation Report at the end of the certificate. All figures stated in the certificate are valid at the frequency indicated.
- *Antenna Parameters with TSL:* The source is mounted in a touch configuration below the center marking of the flat phantom.
- *Return Loss:* This parameter is measured with the source positioned under the liquid filled phantom (as described in the measurement condition clause). The Return Loss ensures low reflected power. No uncertainty required.
- *SAR measured:* SAR measured at the stated antenna input power.
- *SAR normalized:* SAR as measured, normalized to an input power of 1 W at the antenna connector.
- *SAR for nominal TSL parameters:* The measured TSL parameters are used to calculate the nominal SAR result.

The reported uncertainty of measurement is stated as the standard uncertainty of measurement multiplied by the coverage factor k=2, which for a normal distribution corresponds to a coverage probability of approximately 95%.

Measurement Conditions

DASY system configuration, as far as not given on page 1.

DASY Version	DASY52	V52.10.4
Extrapolation	Advanced Extrapolation	
Phantom	Modular Flat Phantom	
Distance Dipole Center - TSL	15 mm	with Spacer
Zoom Scan Resolution	dx, dy, dz = 5 mm	
Frequency	750 MHz ± 1 MHz	

Head TSL parameters

The following parameters and calculations were applied.

	Temperature	Permittivity	Conductivity
Nominal Head TSL parameters	22.0 °C	41.9	0.89 mho/m
Measured Head TSL parameters	(22.0 ± 0.2) °C	41.0 ± 6 %	0.90 mho/m ± 6 %
Head TSL temperature change during test	< 0.5 °C	----	----

SAR result with Head TSL

SAR averaged over 1 cm ³ (1 g) of Head TSL	Condition	
SAR measured	250 mW input power	2.13 W/kg
SAR for nominal Head TSL parameters	normalized to 1W	8.41 W/kg ± 17.0 % (k=2)

SAR averaged over 10 cm ³ (10 g) of Head TSL	condition	
SAR measured	250 mW input power	1.38 W/kg
SAR for nominal Head TSL parameters	normalized to 1W	5.46 W/kg ± 16.5 % (k=2)

Appendix (Additional assessments outside the scope of SCS 0108)

Antenna Parameters with Head TSL

Impedance, transformed to feed point	53.3 Ω - 1.0 jΩ
Return Loss	- 29.5 dB

General Antenna Parameters and Design

Electrical Delay (one direction)	1.033 ns
----------------------------------	----------

After long term use with 100W radiated power, only a slight warming of the dipole near the feedpoint can be measured.

The dipole is made of standard semirigid coaxial cable. The center conductor of the feeding line is directly connected to the second arm of the dipole. The antenna is therefore short-circuited for DC-signals. On some of the dipoles, small end caps are added to the dipole arms in order to improve matching when loaded according to the position as explained in the "Measurement Conditions" paragraph. The SAR data are not affected by this change. The overall dipole length is still according to the Standard.

No excessive force must be applied to the dipole arms, because they might bend or the soldered connections near the feedpoint may be damaged.

Additional EUT Data

Manufactured by	SPEAG
-----------------	-------

DASY5 Validation Report for Head TSL

Date: 24.03.2023

Test Laboratory: SPEAG, Zurich, Switzerland

DUT: Dipole 750 MHz; Type: D750V3; Serial: D750V3 - SN:1229

Communication System: UID 0 - CW; Frequency: 750 MHz
 Medium parameters used: $f = 750 \text{ MHz}$; $\sigma = 0.9 \text{ S/m}$; $\epsilon_r = 41$; $\rho = 1000 \text{ kg/m}^3$
 Phantom section: Flat Section
 Measurement Standard: DASY5 (IEEE/IEC/ANSI C63.19-2011)

DASY52 Configuration:

- Probe: EX3DV4 - SN7349; ConvF(10.11, 10.11, 10.11) @ 750 MHz; Calibrated: 10.01.2023
- Sensor-Surface: 1.4mm (Mechanical Surface Detection)
- Electronics: DAE4 Sn601; Calibrated: 19.12.2022
- Phantom: Flat Phantom 4.9 (front); Type: QD 00L P49 AA; Serial: 1001
- DASY52 52.10.4(1535); SEMCAD X 14.6.14(7501)

Dipole Calibration for Head Tissue/Pin=250 mW, d=15mm/Zoom Scan (7x7x7)/Cube 0:

Measurement grid: $dx=5\text{mm}$, $dy=5\text{mm}$, $dz=5\text{mm}$
 Reference Value = 59.57 V/m; Power Drift = -0.09 dB
 Peak SAR (extrapolated) = 3.20 W/kg
SAR(1 g) = 2.13 W/kg; SAR(10 g) = 1.38 W/kg
 Smallest distance from peaks to all points 3 dB below = 17 mm
 Ratio of SAR at M2 to SAR at M1 = 66.2%
 Maximum value of SAR (measured) = 2.83 W/kg

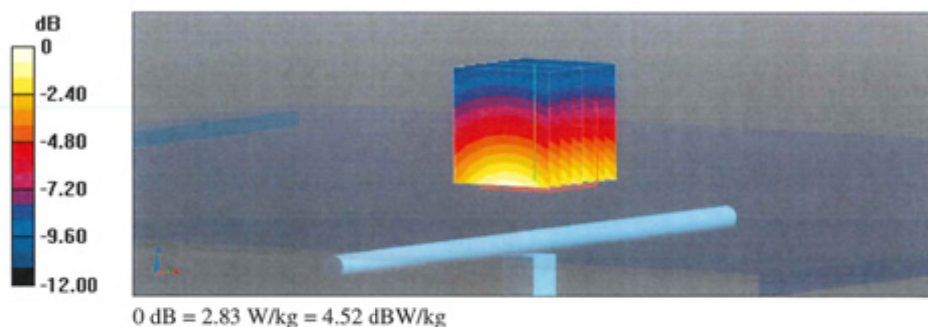

Impedance Measurement Plot for Head TSL

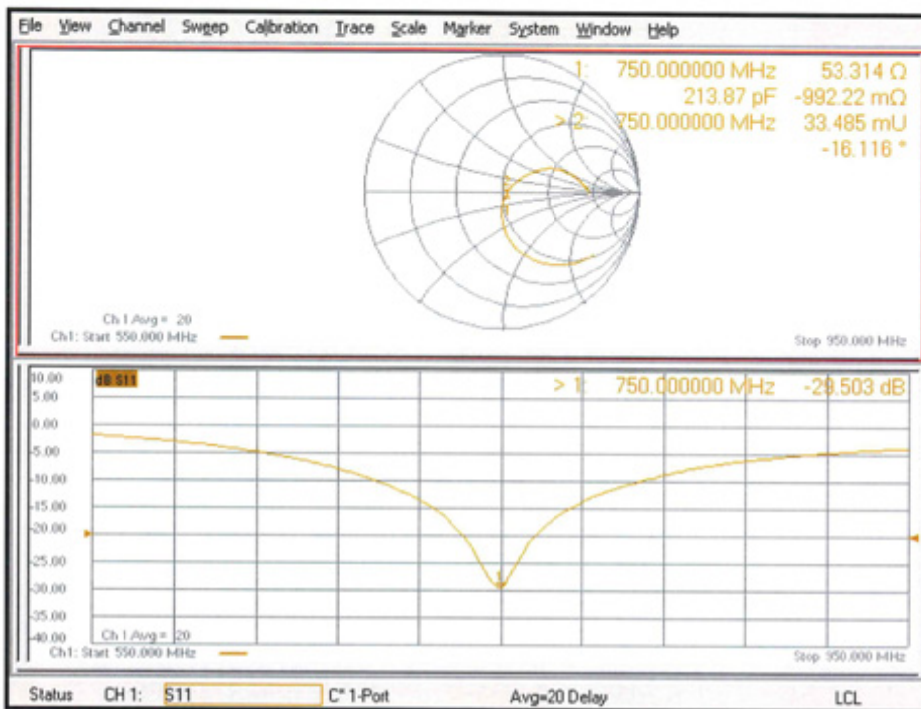



In Collaboration with
s p e a g
CALIBRATION LABORATORY



中国认可
国际互认
校准
CALIBRATION
CNAS L0570

Add: No.51 Xueyuan Road, Haidian District, Beijing, 100191, China
Tel: +86-10-62304633-2079 Fax: +86-10-62304633-2504
E-mail: cntl@chinattl.com http://www.chinattl.cn

Client **BACL**

Certificate No: **Z20-60410**

CALIBRATION CERTIFICATE

Object **D900V2 - SN:132**

Calibration Procedure(s) **FF-Z11-003-01**
Calibration Procedures for dipole validation kits

Calibration date: **October 15, 2020**

This calibration Certificate documents the traceability to national standards, which realize the physical units of measurements(SI). The measurements and the uncertainties with confidence probability are given on the following pages and are part of the certificate.

All calibrations have been conducted in the closed laboratory facility: environment temperature(22±3)°C and humidity<70%.

Calibration Equipment used (M&TE critical for calibration)

Primary Standards	ID #	Cal Date(Calibrated by, Certificate No.)	Scheduled Calibration
Power Meter NRP2	106276	12-May-20 (CTTL, No.J20X02965)	May-21
Power sensor NRP6A	101369	12-May-20 (CTTL, No.J20X02965)	May-21
Reference Probe EX3DV4	SN 3617	30-Jan-20(SPEAG,No.EX3-3617_Jan20)	Jan-21
DAE4	SN 771	10-Feb-20(CTTL-SPEAG,No.Z20-60017)	Feb-21
Secondary Standards	ID #	Cal Date(Calibrated by, Certificate No.)	Scheduled Calibration
Signal Generator E4438C	MY49071430	25-Feb-20 (CTTL, No.J20X00516)	Feb-21
NetworkAnalyzer E5071C	MY46107873	10-Feb-20 (CTTL, No.J20X00515)	Feb-21

	Name	Function	Signature
Calibrated by:	Zhao Jing	SAR Test Engineer	
Reviewed by:	Lin Hao	SAR Test Engineer	
Approved by:	Qi Dianyuan	SAR Project Leader	

Issued: October 22, 2020

This calibration certificate shall not be reproduced except in full without written approval of the laboratory.



Add: No.51 Xueyuan Road, Haidian District, Beijing, 100191, China
 Tel: +86-10-62304633-2079 Fax: +86-10-62304633-2504
 E-mail: cttl@chinattl.com http://www.chinattl.cn

Glossary:

TSL	tissue simulating liquid
ConvF	sensitivity in TSL / NORMx,y,z
N/A	not applicable or not measured

Calibration is Performed According to the Following Standards:

- a) IEEE Std 1528-2013, "IEEE Recommended Practice for Determining the Peak Spatial-Averaged Specific Absorption Rate (SAR) in the Human Head from Wireless Communications Devices: Measurement Techniques", February 2013
- b) IEC 62209-1, "Measurement procedure for assessment of specific absorption rate of human exposure to radio frequency fields from hand-held and body-mounted wireless communication devices- Part 1: Device used next to the ear (Frequency range of 300MHz to 6GHz)", July 2016
- c) IEC 62209-2, "Procedure to measure the Specific Absorption Rate (SAR) For wireless communication devices used in close proximity to the human body (frequency range of 30MHz to 6GHz)", March 2010
- d) KDB865664, SAR Measurement Requirements for 100 MHz to 6 GHz

Additional Documentation:

- e) DASY4/5 System Handbook

Methods Applied and Interpretation of Parameters:

- *Measurement Conditions:* Further details are available from the Validation Report at the end of the certificate. All figures stated in the certificate are valid at the frequency indicated.
- *Antenna Parameters with TSL:* The dipole is mounted with the spacer to position its feed point exactly below the center marking of the flat phantom section, with the arms oriented parallel to the body axis.
- *Feed Point Impedance and Return Loss:* These parameters are measured with the dipole positioned under the liquid filled phantom. The impedance stated is transformed from the measurement at the SMA connector to the feed point. The Return Loss ensures low reflected power. No uncertainty required.
- *Electrical Delay:* One-way delay between the SMA connector and the antenna feed point. No uncertainty required.
- *SAR measured:* SAR measured at the stated antenna input power.
- *SAR normalized:* SAR as measured, normalized to an input power of 1 W at the antenna connector.
- *SAR for nominal TSL parameters:* The measured TSL parameters are used to calculate the nominal SAR result.

The reported uncertainty of measurement is stated as the standard uncertainty of Measurement multiplied by the coverage factor k=2, which for a normal distribution corresponds to a coverage probability of approximately 95%.



Add: No.51 Xueyuan Road, Haidian District, Beijing, 100191, China
 Tel: +86-10-62304633-2079 Fax: +86-10-62304633-2504
 E-mail: ctt@chinattl.com http://www.chinattl.cn

Measurement Conditions

DASY system configuration, as far as not given on page 1.

DASY Version	DASY52	52.10.4
Extrapolation	Advanced Extrapolation	
Phantom	Triple Flat Phantom 5.1C	
Distance Dipole Center - TSL	15 mm	with Spacer
Zoom Scan Resolution	dx, dy, dz = 5 mm	
Frequency	900 MHz ± 1 MHz	

Head TSL parameters

The following parameters and calculations were applied.

	Temperature	Permittivity	Conductivity
Nominal Head TSL parameters	22.0 °C	41.5	0.97 mho/m
Measured Head TSL parameters	(22.0 ± 0.2) °C	41.6 ± 6 %	0.97 mho/m ± 6 %
Head TSL temperature change during test	<1.0 °C	----	----

SAR result with Head TSL

SAR averaged over 1 cm ³ (1 g) of Head TSL	Condition	
SAR measured	250 mW input power	2.70 W/kg
SAR for nominal Head TSL parameters	normalized to 1W	10.8 W/kg ± 18.8 % (k=2)
SAR averaged over 10 cm ³ (10 g) of Head TSL	Condition	
SAR measured	250 mW input power	1.77 W/kg
SAR for nominal Head TSL parameters	normalized to 1W	7.10 W/kg ± 18.7 % (k=2)



Add: No.51 Xueyuan Road, Haidian District, Beijing, 100191, China
 Tel: +86-10-62304633-2079 Fax: +86-10-62304633-2504
 E-mail: cttl@chinattl.com http://www.chinattl.cn

Appendix (Additional assessments outside the scope of CNAS L0570)

Antenna Parameters with Head TSL

Impedance, transformed to feed point	49.1Ω- 7.80jΩ
Return Loss	- 22.0dB

General Antenna Parameters and Design

Electrical Delay (one direction)	1.271 ns
----------------------------------	----------

After long term use with 100W radiated power, only a slight warming of the dipole near the feedpoint can be measured.

The dipole is made of standard semirigid coaxial cable. The center conductor of the feeding line is directly connected to the second arm of the dipole. The antenna is therefore short-circuited for DC-signals. On some of the dipoles, small end caps are added to the dipole arms in order to improve matching when loaded according to the position as explained in the "Measurement Conditions" paragraph. The SAR data are not affected by this change. The overall dipole length is still according to the Standard. No excessive force must be applied to the dipole arms, because they might bend or the soldered connections near the feedpoint may be damaged.

Additional EUT Data

Manufactured by	SPEAG
-----------------	-------



Add: No.51 Xueyuan Road, Haidian District, Beijing, 100191, China
 Tel: +86-10-62304633-2079 Fax: +86-10-62304633-2504
 E-mail: cttl@chinattl.com http://www.chinattl.cn

DASY5 Validation Report for Head TSL

Date: 10.15.2020

Test Laboratory: CTTL, Beijing, China

DUT: Dipole 900 MHz; Type: D900V2; Serial: D900V2 - SN: 132

Communication System: UJD 0, CW; Frequency: 900 MHz; Duty Cycle: 1:1

Medium parameters used: $f = 900 \text{ MHz}$; $\sigma = 0.966 \text{ S/m}$; $\epsilon_r = 41.62$; $\rho = 1000 \text{ kg/m}^3$

Phantom section: Right Section

DASY5 Configuration:

- Probe: EX3DV4 - SN3617; ConvF(9.56, 9.56, 9.56) @ 900 MHz; Calibrated: 2020-01-30
- Sensor-Surface: 1.4mm (Mechanical Surface Detection)
- Electronics: DAE4 Sn771; Calibrated: 2020-02-10
- Phantom: MFP_V5.1C (20deg probe tilt); Type: QD 000 P51 Cx; Serial: 1062
- Measurement SW: DASY52, Version 52.10 (4); SEMCAD X Version 14.6.14 (7483)

Dipole Calibration/Zoom Scan (7x7x7) (7x7x7)/Cube 0: Measurement grid: $dx=5\text{mm}$, $dy=5\text{mm}$, $dz=5\text{mm}$

Reference Value = 60.21 V/m; Power Drift = -0.02 dB

Peak SAR (extrapolated) = 3.97 W/kg

SAR(1 g) = 2.7 W/kg; SAR(10 g) = 1.77 W/kg

Smallest distance from peaks to all points 3 dB below = 15.5 mm

Ratio of SAR at M2 to SAR at M1 = 68.2%

Maximum value of SAR (measured) = 3.55 W/kg

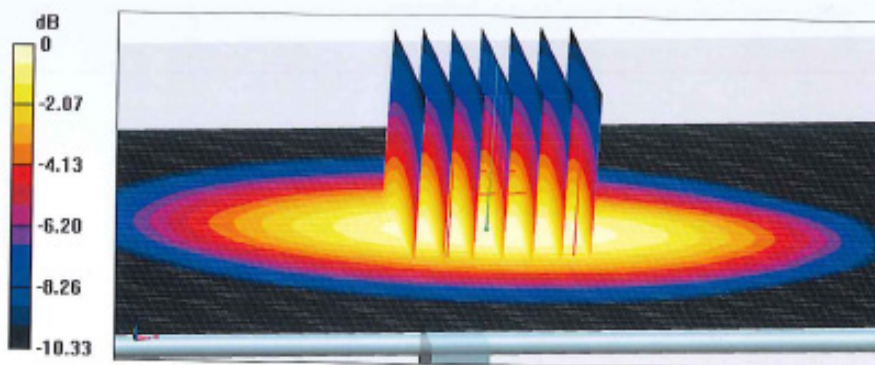

0 dB = 3.55 W/kg = 5.50 dBW/kg



Add: No.51 Xueyuan Road, Haidian District, Beijing, 100191, China
Tel: +86-10-62304633-2079 Fax: +86-10-62304633-2504
E-mail: cttl@chinattl.com http://www.chinattl.cn

Impedance Measurement Plot for Head TSL

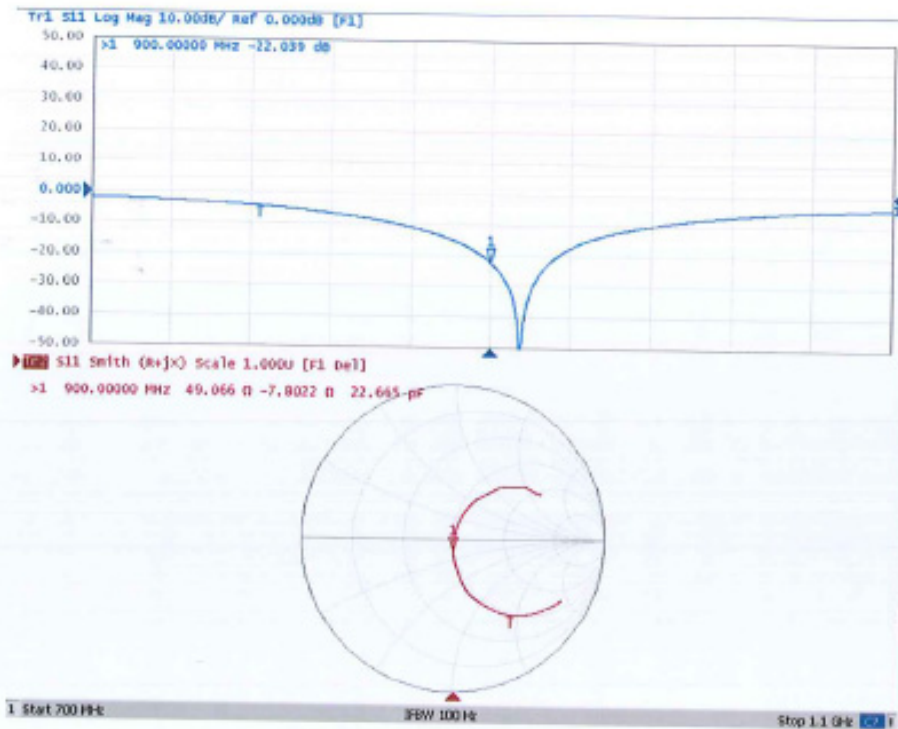

**Calibration Laboratory of
Schmid & Partner
Engineering AG**
Zeughausstrasse 43, 8004 Zurich, Switzerland



S Schweizerischer Kalibrierdienst
C Service suisse d'étalonnage
S Servizio svizzero di taratura
S Swiss Calibration Service

Accredited by the Swiss Accreditation Service (SAS)
The Swiss Accreditation Service is one of the signatories to the EA
Multilateral Agreement for the recognition of calibration certificates

Accreditation No.: **SCS 0108**

Client **BACL**
Sunnyvale USA

Certificate No. **D1750V2-1199_Mar23**

CALIBRATION CERTIFICATE

Object **D1750V2 - SN:1199**

Calibration procedure(s) **QA CAL-05,v12
Calibration Procedure for SAR Validation Sources between 0.7-3 GHz**

Calibration date: **March 27, 2023**

This calibration certificate documents the traceability to national standards, which realize the physical units of measurements (SI).
The measurements and the uncertainties with confidence probability are given on the following pages and are part of the certificate.

All calibrations have been conducted in the closed laboratory facility: environment temperature (22 ± 3)°C and humidity < 70%.

Calibration Equipment used (M&TE critical for calibration)

Primary Standards	ID #	Cal Date (Certificate No.)	Scheduled Calibration
Power meter NRP	SN: 104778	04-Apr-22 (No. 217-03525/03524)	Apr-23
Power sensor NRP-Z91	SN: 103244	04-Apr-22 (No. 217-03524)	Apr-23
Power sensor NRP-Z91	SN: 103245	04-Apr-22 (No. 217-03525)	Apr-23
Reference 20 dB Attenuator	SN: BH9394 (20k)	04-Apr-22 (No. 217-03527)	Apr-23
Type-N mismatch combination	SN: 310982 / 06327	04-Apr-22 (No. 217-03528)	Apr-23
Reference Probe EX3DV4	SN: 7349	10-Jan-23 (No. EX3-7349_Jan23)	Jan-24
DAE4	SN: 601	19-Dec-22 (No. DAE4-601_Dec22)	Dec-23

Secondary Standards	ID #	Check Date (in house)	Scheduled Check
Power meter E4419B	SN: GB39512475	30-Oct-14 (in house check Oct-22)	In house check: Oct-24
Power sensor HP 8481A	SN: US37292783	07-Oct-15 (in house check Oct-22)	In house check: Oct-24
Power sensor HP 8481A	SN: MY41093315	07-Oct-15 (in house check Oct-22)	In house check: Oct-24
RF generator R&S SMT-06	SN: 100972	15-Jun-15 (in house check Oct-22)	In house check: Oct-24
Network Analyzer Agilent E8358A	SN: US41080477	31-Mar-14 (in house check Oct-22)	In house check: Oct-24

	Name	Function	Signature
Calibrated by:	Jeton Kastrati	Laboratory Technician	
Approved by:	Sven Kühn	Technical Manager	

Issued: March 27, 2023

This calibration certificate shall not be reproduced except in full without written approval of the laboratory.

**Calibration Laboratory of
Schmid & Partner
Engineering AG**
Zeughausstrasse 43, 8004 Zurich, Switzerland



S Schweizerischer Kalibrierdienst
C Service suisse d'étalonnage
S Servizio svizzero di taratura
S Swiss Calibration Service

Accredited by the Swiss Accreditation Service (SAS)
The Swiss Accreditation Service is one of the signatories to the EA
Multilateral Agreement for the recognition of calibration certificates

Accreditation No.: **SCS 0108**

Glossary:

TSL tissue simulating liquid
ConvF sensitivity in TSL / NORM x,y,z
N/A not applicable or not measured

Calibration is Performed According to the Following Standards:

- a) IEC/IEEE 62209-1528, "Measurement Procedure For The Assessment Of Specific Absorption Rate Of Human Exposure To Radio Frequency Fields From Hand-Held And Body-Worn Wireless Communication Devices - Part 1528: Human Models, Instrumentation And Procedures (Frequency Range of 4 MHz to 10 GHz)", October 2020.
- b) KDB 865664, "SAR Measurement Requirements for 100 MHz to 6 GHz"

Additional Documentation:

- c) DASY System Handbook

Methods Applied and Interpretation of Parameters:

- *Measurement Conditions:* Further details are available from the Validation Report at the end of the certificate. All figures stated in the certificate are valid at the frequency indicated.
- *Antenna Parameters with TSL:* The source is mounted in a touch configuration below the center marking of the flat phantom.
- *Return Loss:* This parameter is measured with the source positioned under the liquid filled phantom (as described in the measurement condition clause). The Return Loss ensures low reflected power. No uncertainty required.
- *SAR measured:* SAR measured at the stated antenna input power.
- *SAR normalized:* SAR as measured, normalized to an input power of 1 W at the antenna connector.
- *SAR for nominal TSL parameters:* The measured TSL parameters are used to calculate the nominal SAR result.

The reported uncertainty of measurement is stated as the standard uncertainty of measurement multiplied by the coverage factor $k=2$, which for a normal distribution corresponds to a coverage probability of approximately 95%.

Measurement Conditions

DASY system configuration, as far as not given on page 1.

DASY Version	DASY52	V52.10.4
Extrapolation	Advanced Extrapolation	
Phantom	Modular Flat Phantom	
Distance Dipole Center - TSL	10 mm	with Spacer
Zoom Scan Resolution	dx, dy, dz = 5 mm	
Frequency	1750 MHz ± 1 MHz	

Head TSL parameters

The following parameters and calculations were applied.

	Temperature	Permittivity	Conductivity
Nominal Head TSL parameters	22.0 °C	40.1	1.37 mho/m
Measured Head TSL parameters	(22.0 ± 0.2) °C	38.8 ± 6 %	1.33 mho/m ± 6 %
Head TSL temperature change during test	< 0.5 °C	----	----

SAR result with Head TSL

SAR averaged over 1 cm ³ (1 g) of Head TSL	Condition	
SAR measured	250 mW input power	8.89 W/kg
SAR for nominal Head TSL parameters	normalized to 1W	36.0 W/kg ± 17.0 % (k=2)

SAR averaged over 10 cm ³ (10 g) of Head TSL	condition	
SAR measured	250 mW input power	4.69 W/kg
SAR for nominal Head TSL parameters	normalized to 1W	18.9 W/kg ± 16.5 % (k=2)

Appendix (Additional assessments outside the scope of SCS 0108)

Antenna Parameters with Head TSL

Impedance, transformed to feed point	46.9 Ω + 3.8 jΩ
Return Loss	- 26.0 dB

General Antenna Parameters and Design

Electrical Delay (one direction)	1.211 ns
----------------------------------	----------

After long term use with 100W radiated power, only a slight warming of the dipole near the feedpoint can be measured.

The dipole is made of standard semirigid coaxial cable. The center conductor of the feeding line is directly connected to the second arm of the dipole. The antenna is therefore short-circuited for DC-signals. On some of the dipoles, small end caps are added to the dipole arms in order to improve matching when loaded according to the position as explained in the "Measurement Conditions" paragraph. The SAR data are not affected by this change. The overall dipole length is still according to the Standard.

No excessive force must be applied to the dipole arms, because they might bend or the soldered connections near the feedpoint may be damaged.

Additional EUT Data

Manufactured by	SPEAG
-----------------	-------

DASY5 Validation Report for Head TSL

Date: 27.03.2023

Test Laboratory: SPEAG, Zurich, Switzerland

DUT: Dipole 1750 MHz; Type: D1750V2; Serial: D1750V2 - SN:1199

Communication System: UID 0 - CW; Frequency: 1750 MHz
 Medium parameters used: $f = 1750$ MHz; $\sigma = 1.33$ S/m; $\epsilon_r = 38.8$; $\rho = 1000$ kg/m³
 Phantom section: Flat Section
 Measurement Standard: DASY5 (IEEE/IEC/ANSI C63.19-2011)

DASY52 Configuration:

- Probe: EX3DV4 - SN7349; ConvF(8.67, 8.67, 8.67) @ 1750 MHz; Calibrated: 10.01.2023
- Sensor-Surface: 1.4mm (Mechanical Surface Detection)
- Electronics: DAE4 Sn601; Calibrated: 19.12.2022
- Phantom: Flat Phantom 5.0 (front); Type: QD 000 P50 AA; Serial: 1001
- DASY52 52.10.4(1535); SEMCAD X 14.6.14(7501)

Dipole Calibration for Head Tissue/Pin=250 mW, d=10mm/Zoom Scan (7x7x7)/Cube 0:

Measurement grid: dx=5mm, dy=5mm, dz=5mm
 Reference Value = 104.8 V/m; Power Drift = 0.05 dB
 Peak SAR (extrapolated) = 16.3 W/kg
SAR(1 g) = 8.89 W/kg; SAR(10 g) = 4.69 W/kg
 Smallest distance from peaks to all points 3 dB below = 10 mm
 Ratio of SAR at M2 to SAR at M1 = 54.5%
 Maximum value of SAR (measured) = 13.8 W/kg

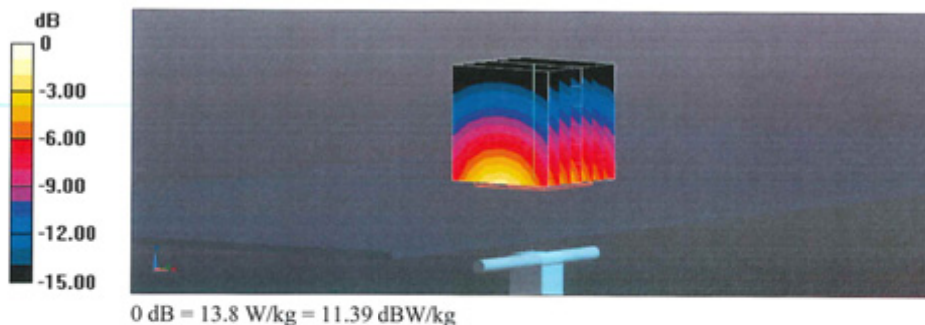

Impedance Measurement Plot for Head TSL

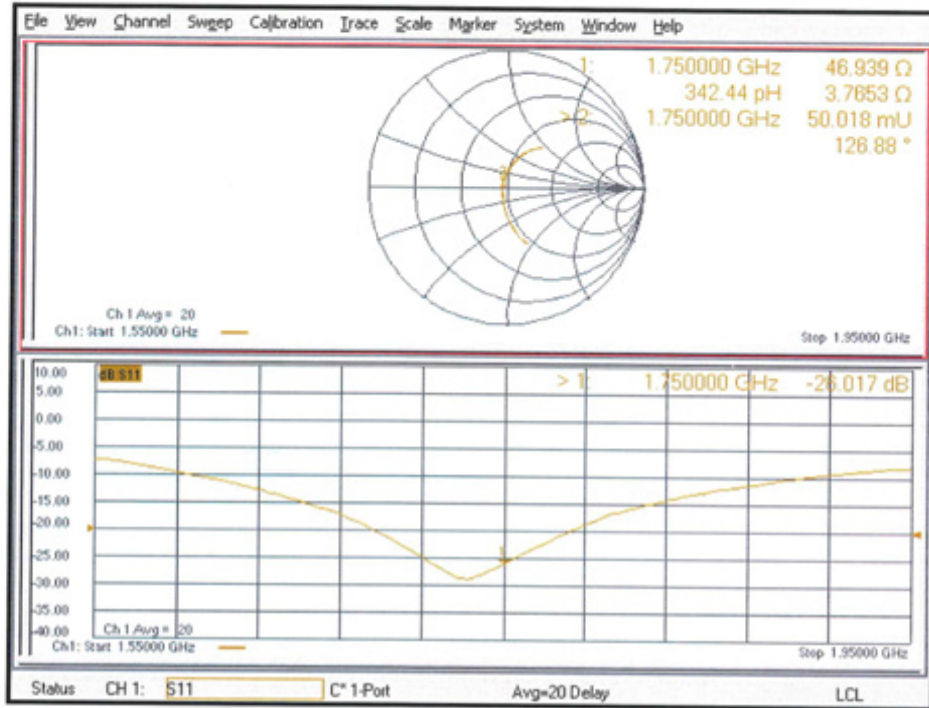



中国认可
国际互认
校准
CALIBRATION
CNAS L0570



Add: No.52 HuaYuanBei Road, Haidian District, Beijing, 100191
Tel: +86-10-62304633-2117
E-mail: emfi@caict.ac.cn http://www.caict.ac.cn

Client **BACL**

Certificate No: **Z23-60084**

CALIBRATION CERTIFICATE			
Object	D1900V2 - SN: 5d231		
Calibration Procedure(s)	FF-Z11-003-01 Calibration Procedures for dipole validation kits		
Calibration date:	February 17, 2023		
<p>This calibration Certificate documents the traceability to national standards, which realize the physical units of measurements (SI). The measurements and the uncertainties with confidence probability are given on the following pages and are part of the certificate.</p> <p>All calibrations have been conducted in the closed laboratory facility: environment temperature (22±3)°C and humidity<70%.</p> <p>Calibration Equipment used (M&TE critical for calibration)</p>			
Primary Standards	ID #	Cal Date (Calibrated by, Certificate No.)	Scheduled Calibration
Power Meter NRP2	106276	10-May-22 (CTTL, No.J22X03103)	May-23
Power sensor NRP6A	101369	10-May-22 (CTTL, No.J22X03103)	May-23
Reference Probe EX3DV4	SN 7464	19-Jan-23 (CTTL-SPEAG, No.Z22-60565)	Jan-24
DAE4	SN 1556	11-Jan-23(CTTL-SPEAG, No.Z23-60034)	Jan-24
Secondary Standards	ID #	Cal Date (Calibrated by, Certificate No.)	Scheduled Calibration
Signal Generator E4438C	MY49070393	17-May-23 (CTTL, No.J22X03157)	May-24
NetworkAnalyzer E5071C	MY46110673	10-Jan-23 (CTTL, No. J23X00104)	Jan-24
Calibrated by:	Name Zhao Jing	Function SAR Test Engineer	Signature
Reviewed by:	Name Lin Hao	Function SAR Test Engineer	Signature
Approved by:	Name Qi Dianyuan	Function SAR Project Leader	Signature
Issued: February 24, 2023			
This calibration certificate shall not be reproduced except in full without written approval of the laboratory.			



Add: No.52 HuaYuanBei Road, Haidian District, Beijing, 100191, China
 Tel: +86-10-62304633-2117
 E-mail: cttl@chinattl.com <http://www.caict.ac.cn>

Glossary:

TSL	tissue simulating liquid
ConvF	sensitivity in TSL / NORM _{x,y,z}
N/A	not applicable or not measured

Calibration is Performed According to the Following Standards:

- IEC/IEEE 62209-1528, "Measurement Procedure for The Assessment of Specific Absorption Rate of Human Exposure to Radio Frequency Fields from Hand-held and Body-mounted Wireless Communication Devices- Part 1528: Human Models, Instrumentation and Procedures (Frequency range of 4 MHz to 10 GHz)", October 2020
- KDB 865664, "SAR Measurement Requirements for 100 MHz to 6 GHz"

Additional Documentation:

- DASY4/5 System Handbook

Methods Applied and Interpretation of Parameters:

- Measurement Conditions:** Further details are available from the Validation Report at the end of the certificate. All figures stated in the certificate are valid at the frequency indicated.
- Antenna Parameters with TSL:** The dipole is mounted with the spacer to position its feed point exactly below the center marking of the flat phantom section, with the arms oriented parallel to the body axis.
- Feed Point Impedance and Return Loss:** These parameters are measured with the dipole positioned under the liquid filled phantom. The impedance stated is transformed from the measurement at the SMA connector to the feed point. The Return Loss ensures low reflected power. No uncertainty required.
- Electrical Delay:** One-way delay between the SMA connector and the antenna feed point. No uncertainty required.
- SAR measured:** SAR measured at the stated antenna input power.
- SAR normalized:** SAR as measured, normalized to an input power of 1 W at the antenna connector.
- SAR for nominal TSL parameters:** The measured TSL parameters are used to calculate the nominal SAR result.

The reported uncertainty of measurement is stated as the standard uncertainty of Measurement multiplied by the coverage factor $k=2$, which for a normal distribution Corresponds to a coverage probability of approximately 95%.



Add: No.52 HuaYuanBei Road, Haidian District, Beijing, 100191, China
 Tel: +86-10-62304633-2117
 E-mail: cttl@chinattl.com http://www.caict.ac.cn

Measurement Conditions

DASY system configuration, as far as not given on page 1.

DASY Version	DASY52	52.10.4
Extrapolation	Advanced Extrapolation	
Phantom	Triple Flat Phantom 5.1C	
Distance Dipole Center - TSL	10 mm	with Spacer
Zoom Scan Resolution	dx, dy, dz = 5 mm	
Frequency	1900 MHz ± 1 MHz	

Head TSL parameters

The following parameters and calculations were applied.

	Temperature	Permittivity	Conductivity
Nominal Head TSL parameters	22.0 °C	40.0	1.40 mho/m
Measured Head TSL parameters	(22.0 ± 0.2) °C	39.0 ± 6 %	1.39 mho/m ± 6 %
Head TSL temperature change during test	<1.0 °C	---	---

SAR result with Head TSL

SAR averaged over 1 cm ³ (1 g) of Head TSL	Condition	
SAR measured	250 mW input power	10.0 W/kg
SAR for nominal Head TSL parameters	normalized to 1W	39.9 W/kg ± 18.8 % (k=2)
SAR averaged over 10 cm ³ (10 g) of Head TSL	Condition	
SAR measured	250 mW input power	5.21 W/kg
SAR for nominal Head TSL parameters	normalized to 1W	20.8 W/kg ± 18.7 % (k=2)



Add: No.52 HuaYuanBei Road, Haidian District, Beijing, 100191, China
 Tel: +86-10-62304633-2117
 E-mail: cttl@chinattl.com http://www.caict.ac.cn

Appendix (Additional assessments outside the scope of CNAS L0570)

Antenna Parameters with Head TSL

Impedance, transformed to feed point	50.3Ω+ 4.99jΩ
Return Loss	- 26.1dB

General Antenna Parameters and Design

Electrical Delay (one direction)	1.105 ns
----------------------------------	----------

After long term use with 100W radiated power, only a slight warming of the dipole near the feed-point can be measured.

The dipole is made of standard semirigid coaxial cable. The center conductor of the feeding line is directly connected to the second arm of the dipole. The antenna is therefore short-circuited for DC-signals. On some of the dipoles, small end caps are added to the dipole arms in order to improve matching when loaded according to the position as explained in the "Measurement Conditions" paragraph. The SAR data are not affected by this change. The overall dipole length is still according to the Standard. No excessive force must be applied to the dipole arms, because they might bend or the soldered connections near the feed-point may be damaged.

Additional EUT Data

Manufactured by	SPEAG
-----------------	-------



Add: No.52 HuaYuanBei Road, Haidian District, Beijing, 100191, China
 Tel: +86-10-62304633-2117
 E-mail: cttl@chinatttl.com <http://www.caict.ac.cn>

DASY5 Validation Report for Head TSL

Date: 2023-02-17

Test Laboratory: CTTL, Beijing, China

DUT: Dipole 1900 MHz; Type: D1900V2; Serial: D1900V2 - SN: 5d231

Communication System: UID 0, CW; Frequency: 1900 MHz

Medium parameters used: $f = 1900$ MHz; $\sigma = 1.393$ S/m; $\epsilon_r = 38.96$; $\rho = 1000$ kg/m³

Phantom section: Right Section

Measurement Standard: DASY5 (IEEE/IEC/ANSI C63.19-2007)

DASY5 Configuration:

- Probe: EX3DV4 - SN7464; ConvF(8.13, 8.13, 8.13) @ 1900 MHz; Calibrated: 2023-01-19
- Sensor-Surface: 1.4mm (Mechanical Surface Detection)
- Electronics: DAE4 Sn1556; Calibrated: 2023-01-11
- Phantom: MFP_V5.1C (20deg probe tilt); Type: QD 000 P51 Cx; Serial: 1062
- DASY52 52.10.4(1535); SEMCAD X 14.6.14(7501)

Dipole Calibration/Zoom Scan (7x7x7) (7x7x7)/Cube 0: Measurement grid: dx=5mm, dy=5mm, dz=5mm

Reference Value = 100.8 V/m; Power Drift = -0.04 dB

Peak SAR (extrapolated) = 18.9 W/kg

SAR(1 g) = 10 W/kg; SAR(10 g) = 5.21 W/kg

Smallest distance from peaks to all points 3 dB below = 10 mm

Ratio of SAR at M2 to SAR at M1 = 53.6%

Maximum value of SAR (measured) = 15.7 W/kg

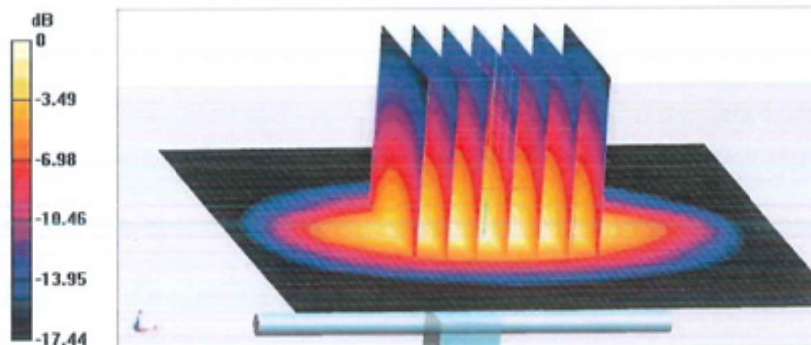

0 dB = 15.7 W/kg = 11.96 dBW/kg



Add: No.52 HuaYuanBei Road, Haidian District, Beijing, 100191, China
Tel: +86-10-62304633-2117
E-mail: cttl@chinattl.com <http://www.caict.ac.cn>

Impedance Measurement Plot for Head TSL

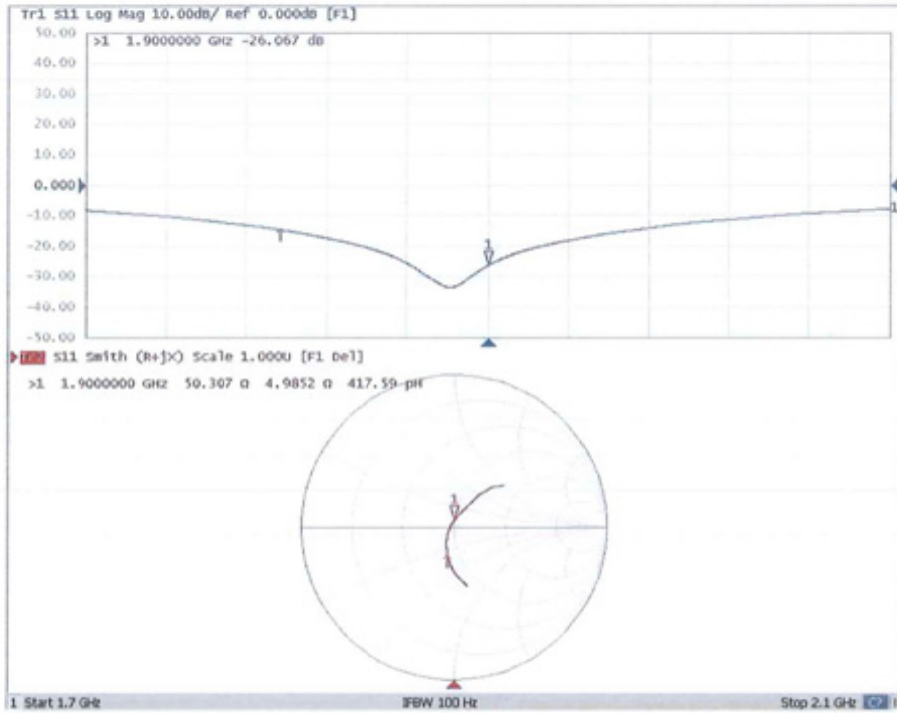

**Calibration Laboratory of
Schmid & Partner
Engineering AG**
Zeughausstrasse 43, 8004 Zurich, Switzerland



S Schweizerischer Kalibrierdienst
C Service suisse d'étalonnage
S Servizio svizzero di taratura
S Swiss Calibration Service

Accredited by the Swiss Accreditation Service (SAS)
The Swiss Accreditation Service is one of the signatories to the EA
Multilateral Agreement for the recognition of calibration certificates

Accreditation No.: **SCS 0108**

Client **BACL**
Sunnyvale, USA

Certificate No. **D2300V2-1136_Mar23**

CALIBRATION CERTIFICATE			
Object	D2300V2 - SN:1136		
Calibration procedure(s)	QA CAL-05.v12 Calibration Procedure for SAR Validation Sources between 0.7-3 GHz		
Calibration date:	March 27, 2023		
This calibration certificate documents the traceability to national standards, which realize the physical units of measurements (SI). The measurements and the uncertainties with confidence probability are given on the following pages and are part of the certificate.			
All calibrations have been conducted in the closed laboratory facility: environment temperature (22 ± 3)°C and humidity < 70%.			
Calibration Equipment used (M&TE critical for calibration)			
Primary Standards	ID #	Cal Date (Certificate No.)	Scheduled Calibration
Power meter NRP	SN: 104778	04-Apr-22 (No. 217-03525/03524)	Apr-23
Power sensor NRP-Z91	SN: 103244	04-Apr-22 (No. 217-03524)	Apr-23
Power sensor NRP-Z91	SN: 103245	04-Apr-22 (No. 217-03525)	Apr-23
Reference 20 dB Attenuator	SN: BH9394 (20k)	04-Apr-22 (No. 217-03527)	Apr-23
Type-N mismatch combination	SN: 310982 / 06327	04-Apr-22 (No. 217-03528)	Apr-23
Reference Probe EX3DV4	SN: 7349	10-Jan-23 (No. EX3-7349_Jan23)	Jan-24
DAE4	SN: 601	19-Dec-22 (No. DAE4-601_Dec22)	Dec-23
Secondary Standards	ID #	Check Date (in house)	Scheduled Check
Power meter E4419B	SN: GB39512475	30-Oct-14 (in house check Oct-22)	In house check: Oct-24
Power sensor HP 8481A	SN: US37292783	07-Oct-15 (in house check Oct-22)	In house check: Oct-24
Power sensor HP 8481A	SN: MY41093315	07-Oct-15 (in house check Oct-22)	In house check: Oct-24
RF generator R&S SMT-06	SN: 100972	15-Jun-15 (in house check Oct-22)	In house check: Oct-24
Network Analyzer Agilent E8358A	SN: US41080477	31-Mar-14 (in house check Oct-22)	In house check: Oct-24
Calibrated by:	Name Jeton Kastrati	Function Laboratory Technician	Signature
Approved by:	Sven Kühn	Technical Manager	
			Issued: March 27, 2023
This calibration certificate shall not be reproduced except in full without written approval of the laboratory.			

**Calibration Laboratory of
Schmid & Partner
Engineering AG**
Zeughausstrasse 43, 8004 Zurich, Switzerland



S Schweizerischer Kalibrierdienst
C Service suisse d'étalonnage
S Servizio svizzero di taratura
S Swiss Calibration Service

Accreditation No.: **SCS 0108**

Accredited by the Swiss Accreditation Service (SAS)
The Swiss Accreditation Service is one of the signatories to the EA
Multilateral Agreement for the recognition of calibration certificates

Glossary:

TSL tissue simulating liquid
ConvF sensitivity in TSL / NORM x,y,z
N/A not applicable or not measured

Calibration is Performed According to the Following Standards:

- a) IEC/IEEE 62209-1528, "Measurement Procedure For The Assessment Of Specific Absorption Rate Of Human Exposure To Radio Frequency Fields From Hand-Held And Body-Worn Wireless Communication Devices - Part 1528: Human Models, Instrumentation And Procedures (Frequency Range of 4 MHz to 10 GHz)", October 2020.
- b) KDB 865664, "SAR Measurement Requirements for 100 MHz to 6 GHz"

Additional Documentation:

- c) DASY System Handbook

Methods Applied and Interpretation of Parameters:

- *Measurement Conditions:* Further details are available from the Validation Report at the end of the certificate. All figures stated in the certificate are valid at the frequency indicated.
- *Antenna Parameters with TSL:* The source is mounted in a touch configuration below the center marking of the flat phantom.
- *Return Loss:* This parameter is measured with the source positioned under the liquid filled phantom (as described in the measurement condition clause). The Return Loss ensures low reflected power. No uncertainty required.
- *SAR measured:* SAR measured at the stated antenna input power.
- *SAR normalized:* SAR as measured, normalized to an input power of 1 W at the antenna connector.
- *SAR for nominal TSL parameters:* The measured TSL parameters are used to calculate the nominal SAR result.

The reported uncertainty of measurement is stated as the standard uncertainty of measurement multiplied by the coverage factor k=2, which for a normal distribution corresponds to a coverage probability of approximately 95%.

Measurement Conditions

DASY system configuration, as far as not given on page 1.

DASY Version	DASY52	V52.10.4
Extrapolation	Advanced Extrapolation	
Phantom	Modular Flat Phantom	
Distance Dipole Center - TSL	10 mm	with Spacer
Zoom Scan Resolution	dx, dy, dz = 5 mm	
Frequency	2300 MHz ± 1 MHz	

Head TSL parameters

The following parameters and calculations were applied.

	Temperature	Permittivity	Conductivity
Nominal Head TSL parameters	22.0 °C	39.5	1.67 mho/m
Measured Head TSL parameters	(22.0 ± 0.2) °C	38.5 ± 6 %	1.65 mho/m ± 6 %
Head TSL temperature change during test	< 0.5 °C	----	----

SAR result with Head TSL

SAR averaged over 1 cm³ (1 g) of Head TSL	Condition	
SAR measured	250 mW input power	12.0 W/kg
SAR for nominal Head TSL parameters	normalized to 1W	48.2 W/kg ± 17.0 % (k=2)

SAR averaged over 10 cm³ (10 g) of Head TSL	condition	
SAR measured	250 mW input power	5.88 W/kg
SAR for nominal Head TSL parameters	normalized to 1W	23.5 W/kg ± 16.5 % (k=2)

Appendix (Additional assessments outside the scope of SCS 0108)

Antenna Parameters with Head TSL

Impedance, transformed to feed point	46.8 Ω + 1.3 jΩ
Return Loss	- 28.9 dB

General Antenna Parameters and Design

Electrical Delay (one direction)	1.166 ns
----------------------------------	----------

After long term use with 100W radiated power, only a slight warming of the dipole near the feedpoint can be measured.

The dipole is made of standard semirigid coaxial cable. The center conductor of the feeding line is directly connected to the second arm of the dipole. The antenna is therefore short-circuited for DC-signals. On some of the dipoles, small end caps are added to the dipole arms in order to improve matching when loaded according to the position as explained in the "Measurement Conditions" paragraph. The SAR data are not affected by this change. The overall dipole length is still according to the Standard.

No excessive force must be applied to the dipole arms, because they might bend or the soldered connections near the feedpoint may be damaged.

Additional EUT Data

Manufactured by	SPEAG
-----------------	-------

DASY5 Validation Report for Head TSL

Date: 27.03.2023

Test Laboratory: SPEAG, Zurich, Switzerland

DUT: Dipole 2300 MHz; Type: D2300V2; Serial: D2300V2 - SN:1136

Communication System: UID 0 - CW; Frequency: 2300 MHz
Medium parameters used: $f = 2300$ MHz; $\sigma = 1.65$ S/m; $\epsilon_r = 38.5$; $\rho = 1000$ kg/m³
Phantom section: Flat Section
Measurement Standard: DASY5 (IEEE/IEC/ANSI C63.19-2011)

DASY52 Configuration:

- Probe: EX3DV4 - SN7349; ConvF(7.98, 7.98, 7.98) @ 2300 MHz; Calibrated: 10.01.2023
- Sensor-Surface: 1.4mm (Mechanical Surface Detection)
- Electronics: DAE4 Sn601; Calibrated: 19.12.2022
- Phantom: Flat Phantom 5.0 (front); Type: QD 000 P50 AA; Serial: 1001
- DASY52 52.10.4(1535); SEMCAD X 14.6.14(7501)

Dipole Calibration for Head Tissue/Pin=250 mW, d=10mm/Zoom Scan (7x7x7)/Cube 0:

Measurement grid: dx=5mm, dy=5mm, dz=5mm
Reference Value = 115.2 V/m; Power Drift = 0.04 dB
Peak SAR (extrapolated) = 21.6 W/kg
SAR(1 g) = 12.0 W/kg; SAR(10 g) = 5.88 W/kg
Smallest distance from peaks to all points 3 dB below = 9 mm
Ratio of SAR at M2 to SAR at M1 = 56.1%
Maximum value of SAR (measured) = 18.7 W/kg

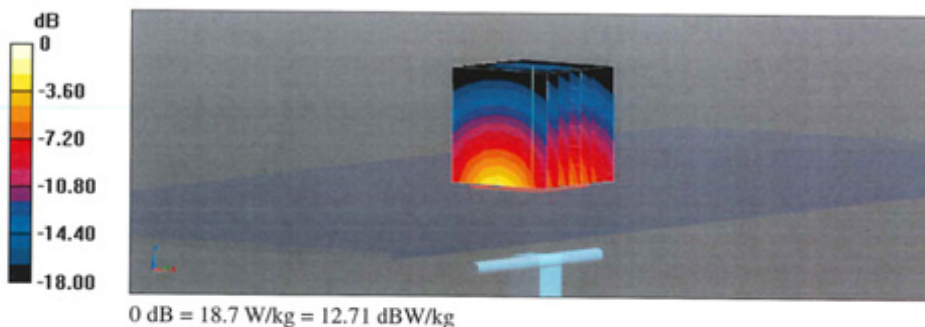

Impedance Measurement Plot for Head TSL

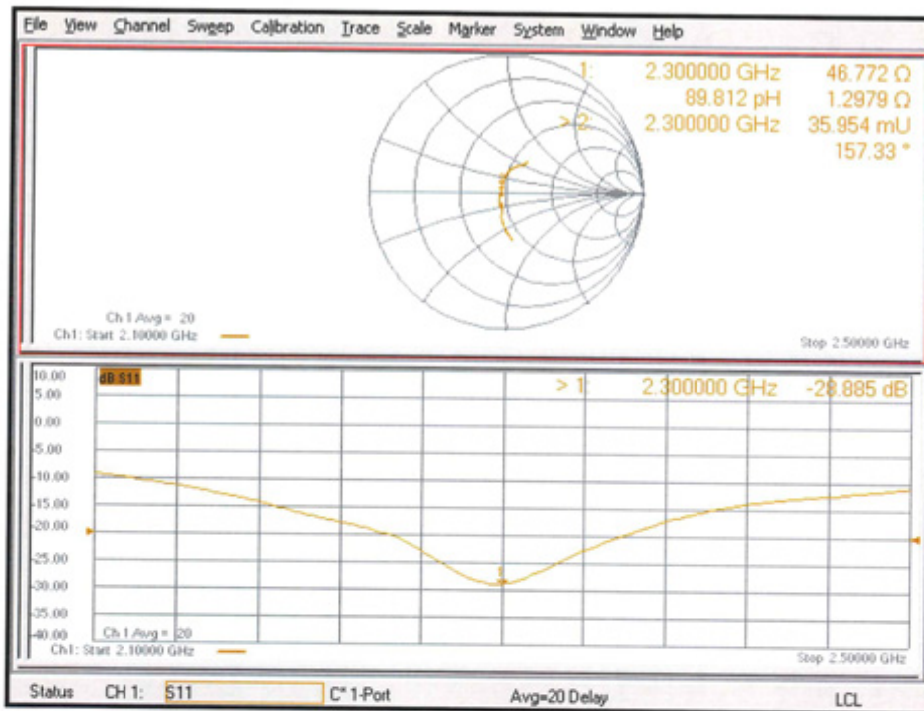

**Calibration Laboratory of
Schmid & Partner
Engineering AG**
Zeughausstrasse 43, 8004 Zurich, Switzerland



S Schweizerischer Kalibrierdienst
C Service suisse d'étalonnage
S Servizio svizzero di taratura
S Swiss Calibration Service

Accreditation No.: **SCS 0108**

Accredited by the Swiss Accreditation Service (SAS)
The Swiss Accreditation Service is one of the signatories to the EA
Multilateral Agreement for the recognition of calibration certificates

Client **BACL**
Sunnyvale, USA

Certificate No. **D2450V2-1103_Mar23**

CALIBRATION CERTIFICATE			
Object	D2450V2 - SN:1103		
Calibration procedure(s)	QA CAL-05.v12 Calibration Procedure for SAR Validation Sources between 0.7-3 GHz		
Calibration date:	March 27, 2023		
This calibration certificate documents the traceability to national standards, which realize the physical units of measurements (SI). The measurements and the uncertainties with confidence probability are given on the following pages and are part of the certificate.			
All calibrations have been conducted in the closed laboratory facility: environment temperature (22 ± 3)°C and humidity < 70%.			
Calibration Equipment used (M&TE critical for calibration)			
Primary Standards	ID #	Cal Date (Certificate No.)	Scheduled Calibration
Power meter NRP	SN: 104778	04-Apr-22 (No. 217-03525/03524)	Apr-23
Power sensor NRP-Z91	SN: 103244	04-Apr-22 (No. 217-03524)	Apr-23
Power sensor NRP-Z91	SN: 103245	04-Apr-22 (No. 217-03525)	Apr-23
Reference 20 dB Attenuator	SN: BH9394 (20k)	04-Apr-22 (No. 217-03527)	Apr-23
Type-N mismatch combination	SN: 310982 / 06327	04-Apr-22 (No. 217-03528)	Apr-23
Reference Probe EX3DV4	SN: 7349	10-Jan-23 (No. EX3-7349_Jan23)	Jan-24
DAE4	SN: 601	19-Dec-22 (No. DAE4-601_Dec22)	Dec-23
Secondary Standards	ID #	Check Date (in house)	Scheduled Check
Power meter E4419B	SN: GB39512475	30-Oct-14 (in house check Oct-22)	In house check: Oct-24
Power sensor HP 8481A	SN: US37292783	07-Oct-15 (in house check Oct-22)	In house check: Oct-24
Power sensor HP 8481A	SN: MY41093315	07-Oct-15 (in house check Oct-22)	In house check: Oct-24
RF generator R&S SMT-06	SN: 100972	15-Jun-15 (in house check Oct-22)	In house check: Oct-24
Network Analyzer Agilent E8358A	SN: US41080477	31-Mar-14 (in house check Oct-22)	In house check: Oct-24
Calibrated by:	Name Jeton Kastrati	Function Laboratory Technician	Signature
Approved by:	Name Sven Kühn	Technical Manager	Signature
			Issued: March 27, 2023
This calibration certificate shall not be reproduced except in full without written approval of the laboratory.			

**Calibration Laboratory of
Schmid & Partner
Engineering AG**
Zeughausstrasse 43, 8004 Zurich, Switzerland



S Schweizerischer Kalibrierdienst
C Service suisse d'étalonnage
S Servizio svizzero di taratura
S Swiss Calibration Service

Accredited by the Swiss Accreditation Service (SAS)
The Swiss Accreditation Service is one of the signatories to the EA
Multilateral Agreement for the recognition of calibration certificates

Accreditation No.: **SCS 0108**

Glossary:

TSL tissue simulating liquid
ConvF sensitivity in TSL / NORM x,y,z
N/A not applicable or not measured

Calibration is Performed According to the Following Standards:

- a) IEC/IEEE 62209-1528, "Measurement Procedure For The Assessment Of Specific Absorption Rate Of Human Exposure To Radio Frequency Fields From Hand-Held And Body-Worn Wireless Communication Devices - Part 1528: Human Models, Instrumentation And Procedures (Frequency Range of 4 MHz to 10 GHz)", October 2020.
- b) KDB 865664, "SAR Measurement Requirements for 100 MHz to 6 GHz"

Additional Documentation:

- c) DASY System Handbook

Methods Applied and Interpretation of Parameters:

- *Measurement Conditions:* Further details are available from the Validation Report at the end of the certificate. All figures stated in the certificate are valid at the frequency indicated.
- *Antenna Parameters with TSL:* The source is mounted in a touch configuration below the center marking of the flat phantom.
- *Return Loss:* This parameter is measured with the source positioned under the liquid filled phantom (as described in the measurement condition clause). The Return Loss ensures low reflected power. No uncertainty required.
- *SAR measured:* SAR measured at the stated antenna input power.
- *SAR normalized:* SAR as measured, normalized to an input power of 1 W at the antenna connector.
- *SAR for nominal TSL parameters:* The measured TSL parameters are used to calculate the nominal SAR result.

The reported uncertainty of measurement is stated as the standard uncertainty of measurement multiplied by the coverage factor k=2, which for a normal distribution corresponds to a coverage probability of approximately 95%.

Measurement Conditions

DASY system configuration, as far as not given on page 1.

DASY Version	DASY52	V52.10.4
Extrapolation	Advanced Extrapolation	
Phantom	Modular Flat Phantom	
Distance Dipole Center - TSL	10 mm	with Spacer
Zoom Scan Resolution	dx, dy, dz = 5 mm	
Frequency	2450 MHz ± 1 MHz	

Head TSL parameters

The following parameters and calculations were applied.

	Temperature	Permittivity	Conductivity
Nominal Head TSL parameters	22.0 °C	39.2	1.80 mho/m
Measured Head TSL parameters	(22.0 ± 0.2) °C	38.0 ± 6 %	1.81 mho/m ± 6 %
Head TSL temperature change during test	< 0.5 °C	----	----

SAR result with Head TSL

SAR averaged over 1 cm ³ (1 g) of Head TSL	Condition	
SAR measured	250 mW input power	13.1 W/kg
SAR for nominal Head TSL parameters	normalized to 1W	51.7 W/kg ± 17.0 % (k=2)

SAR averaged over 10 cm ³ (10 g) of Head TSL	condition	
SAR measured	250 mW input power	6.10 W/kg
SAR for nominal Head TSL parameters	normalized to 1W	24.2 W/kg ± 16.5 % (k=2)

Appendix (Additional assessments outside the scope of SCS 0108)

Antenna Parameters with Head TSL

Impedance, transformed to feed point	53.5 Ω + 5.4 jΩ
Return Loss	- 24.2 dB

General Antenna Parameters and Design

Electrical Delay (one direction)	1.151 ns
----------------------------------	----------

After long term use with 100W radiated power, only a slight warming of the dipole near the feedpoint can be measured.

The dipole is made of standard semirigid coaxial cable. The center conductor of the feeding line is directly connected to the second arm of the dipole. The antenna is therefore short-circuited for DC-signals. On some of the dipoles, small end caps are added to the dipole arms in order to improve matching when loaded according to the position as explained in the "Measurement Conditions" paragraph. The SAR data are not affected by this change. The overall dipole length is still according to the Standard.

No excessive force must be applied to the dipole arms, because they might bend or the soldered connections near the feedpoint may be damaged.

Additional EUT Data

Manufactured by	SPEAG
-----------------	-------

DASY5 Validation Report for Head TSL

Date: 27.03.2023

Test Laboratory: SPEAG, Zurich, Switzerland

DUT: Dipole 2450 MHz; Type: D2450V2; Serial: D2450V2 - SN:1103

Communication System: UID 0 - CW; Frequency: 2450 MHz
 Medium parameters used: $f = 2450$ MHz; $\sigma = 1.81$ S/m; $\epsilon_r = 38$; $\rho = 1000$ kg/m³
 Phantom section: Flat Section
 Measurement Standard: DASY5 (IEEE/IEC/ANSI C63.19-2011)

DASY52 Configuration:

- Probe: EX3DV4 - SN7349; ConvF(7.88, 7.88, 7.88) @ 2450 MHz; Calibrated: 10.01.2023
- Sensor-Surface: 1.4mm (Mechanical Surface Detection)
- Electronics: DAE4 Sn601; Calibrated: 19.12.2022
- Phantom: Flat Phantom 5.0 (front); Type: QD 000 P50 AA; Serial: 1001
- DASY52 52.10.4(1535); SEMCAD X 14.6.14(7501)

Dipole Calibration for Head Tissue/Pin=250 mW, d=10mm/Zoom Scan (7x7x7)/Cube 0:

Measurement grid: dx=5mm, dy=5mm, dz=5mm
 Reference Value = 114.9 V/m; Power Drift = -0.00 dB
 Peak SAR (extrapolated) = 25.3 W/kg
SAR(1 g) = 13.1 W/kg; SAR(10 g) = 6.10 W/kg
 Smallest distance from peaks to all points 3 dB below = 9 mm
 Ratio of SAR at M2 to SAR at M1 = 51.3%
 Maximum value of SAR (measured) = 21.2 W/kg

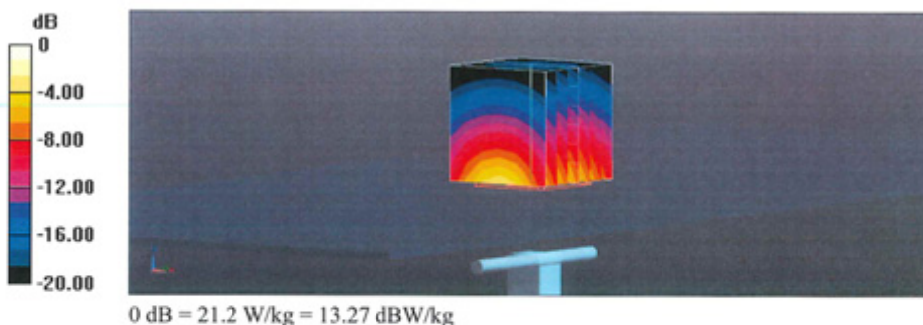

Impedance Measurement Plot for Head TSL

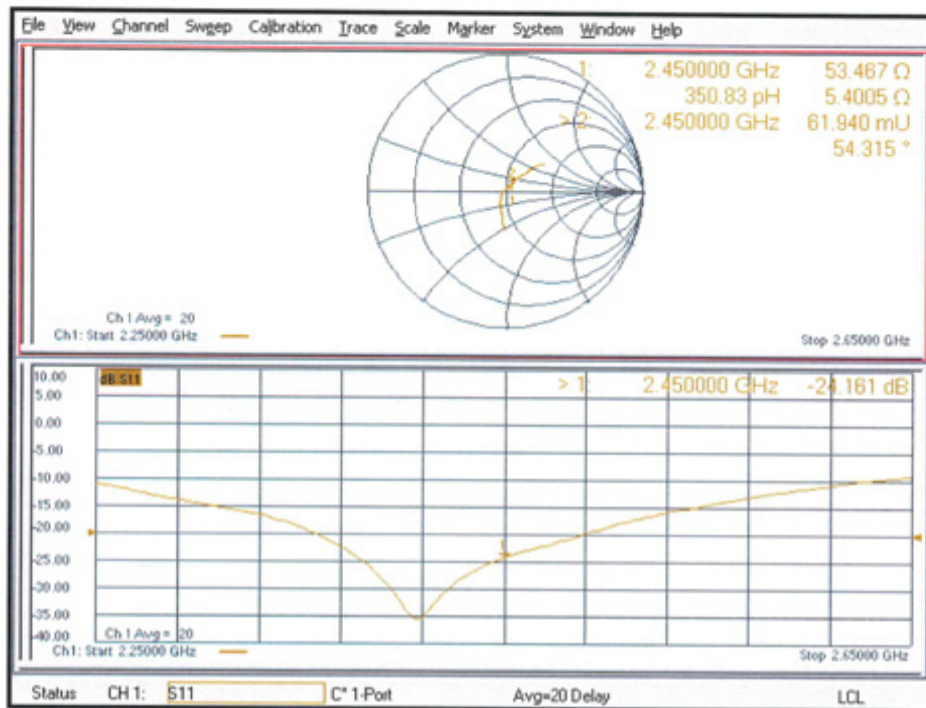

**Calibration Laboratory of
Schmid & Partner
Engineering AG**
Zeughausstrasse 43, 8004 Zurich, Switzerland



S Schweizerischer Kalibrierdienst
C Service suisse d'étalonnage
S Servizio svizzero di taratura
S Swiss Calibration Service

Accredited by the Swiss Accreditation Service (SAS)
The Swiss Accreditation Service is one of the signatories to the EA
Multilateral Agreement for the recognition of calibration certificates

Accreditation No.: **SCS 0108**

Client **BACL**
Sunnyvale USA

Certificate No. **D5GHzV2-1374_Mar23**

CALIBRATION CERTIFICATE

Object **D5GHzV2 - SN:1374**

Calibration procedure(s) **QA CAL-22.v7
Calibration Procedure for SAR Validation Sources between 3-10 GHz**

Calibration date: **March 27, 2023**

This calibration certificate documents the traceability to national standards, which realize the physical units of measurements (SI).
The measurements and the uncertainties with confidence probability are given on the following pages and are part of the certificate.

All calibrations have been conducted in the closed laboratory facility: environment temperature (22 ± 3)°C and humidity < 70%.

Calibration Equipment used (M&TE critical for calibration)

Primary Standards	ID #	Cal Date (Certificate No.)	Scheduled Calibration
Power meter NRP	SN: 104778	04-Apr-22 (No. 217-03525/03524)	Apr-23
Power sensor NRP-Z91	SN: 103244	04-Apr-22 (No. 217-03524)	Apr-23
Power sensor NRP-Z91	SN: 103245	04-Apr-22 (No. 217-03525)	Apr-23
Reference 20 dB Attenuator	SN: BH9394 (20k)	04-Apr-22 (No. 217-03527)	Apr-23
Type-N mismatch combination	SN: 310982 / 06327	04-Apr-22 (No. 217-03528)	Apr-23
Reference Probe EX3DV4	SN: 3503	07-Mar-23 (No. EX3-3503_Mar23)	Mar-24
DAE4	SN: 601	19-Dec-22 (No. DAE4-601_Dec22)	Dec-23

Secondary Standards	ID #	Check Date (in house)	Scheduled Check
Power meter E4419B	SN: GB39512475	30-Oct-14 (in house check Oct-22)	In house check: Oct-24
Power sensor HP 8481A	SN: US37292783	07-Oct-15 (in house check Oct-22)	In house check: Oct-24
Power sensor HP 8481A	SN: MY41093315	07-Oct-15 (in house check Oct-22)	In house check: Oct-24
RF generator R&S SMT-06	SN: 100972	15-Jun-15 (in house check Oct-22)	In house check: Oct-24
Network Analyzer Agilent E8358A	SN: US41080477	31-Mar-14 (in house check Oct-22)	In house check: Oct-24

Calibrated by:	Name	Function	Signature
	Jeton Kastrali	Laboratory Technician	

Approved by:	Name	Function	Signature
	Sven Kühn	Technical Manager	

Issued: March 29, 2023

This calibration certificate shall not be reproduced except in full without written approval of the laboratory.

**Calibration Laboratory of
Schmid & Partner
Engineering AG**
Zeughausstrasse 43, 8004 Zurich, Switzerland



S Schweizerischer Kalibrierdienst
C Service suisse d'étalonnage
S Servizio svizzero di taratura
S Swiss Calibration Service

Accredited by the Swiss Accreditation Service (SAS)
The Swiss Accreditation Service is one of the signatories to the EA
Multilateral Agreement for the recognition of calibration certificates

Accreditation No.: **SCS 0108**

Glossary:

TSL tissue simulating liquid
ConvF sensitivity in TSL / NORM x,y,z
N/A not applicable or not measured

Calibration is Performed According to the Following Standards:

- a) IEC/IEEE 62209-1528, "Measurement Procedure For The Assessment Of Specific Absorption Rate Of Human Exposure To Radio Frequency Fields From Hand-Held And Body-Worn Wireless Communication Devices - Part 1528: Human Models, Instrumentation And Procedures (Frequency Range of 4 MHz to 10 GHz)", October 2020.
- b) KDB 865664, "SAR Measurement Requirements for 100 MHz to 6 GHz"

Additional Documentation:

- c) DASY System Handbook

Methods Applied and Interpretation of Parameters:

- *Measurement Conditions:* Further details are available from the Validation Report at the end of the certificate. All figures stated in the certificate are valid at the frequency indicated.
- *Antenna Parameters with TSL:* The source is mounted in a touch configuration below the center marking of the flat phantom.
- *Return Loss:* This parameter is measured with the source positioned under the liquid filled phantom (as described in the measurement condition clause). The Return Loss ensures low reflected power. No uncertainty required.
- *SAR measured:* SAR measured at the stated antenna input power.
- *SAR normalized:* SAR as measured, normalized to an input power of 1 W at the antenna connector.
- *SAR for nominal TSL parameters:* The measured TSL parameters are used to calculate the nominal SAR result.

The reported uncertainty of measurement is stated as the standard uncertainty of measurement multiplied by the coverage factor k=2, which for a normal distribution corresponds to a coverage probability of approximately 95%.

Measurement Conditions

DASY system configuration, as far as not given on page 1.

DASY Version	DASY52	V52.10.4
Extrapolation	Advanced Extrapolation	
Phantom	Modular Flat Phantom V5.0	
Distance Dipole Center - TSL	10 mm	with Spacer
Zoom Scan Resolution	dx, dy = 4.0 mm, dz = 1.4 mm	Graded Ratio = 1.4 (Z direction)
Frequency	5250 MHz ± 1 MHz 5600 MHz ± 1 MHz 5800 MHz ± 1 MHz	

Head TSL parameters at 5250 MHz

The following parameters and calculations were applied.

	Temperature	Permittivity	Conductivity
Nominal Head TSL parameters	22.0 °C	35.9	4.71 mho/m
Measured Head TSL parameters	(22.0 ± 0.2) °C	35.8 ± 6 %	4.71 mho/m ± 6 %
Head TSL temperature change during test	< 0.5 °C	----	----

SAR result with Head TSL at 5250 MHz

SAR averaged over 1 cm ³ (1 g) of Head TSL	Condition	
SAR measured	100 mW input power	8.01 W/kg
SAR for nominal Head TSL parameters	normalized to 1W	80.1 W/kg ± 19.9 % (k=2)

SAR averaged over 10 cm ³ (10 g) of Head TSL	condition	
SAR measured	100 mW input power	2.31 W/kg
SAR for nominal Head TSL parameters	normalized to 1W	23.1 W/kg ± 19.5 % (k=2)

Head TSL parameters at 5600 MHz

The following parameters and calculations were applied.

	Temperature	Permittivity	Conductivity
Nominal Head TSL parameters	22.0 °C	35.5	5.07 mho/m
Measured Head TSL parameters	(22.0 ± 0.2) °C	35.6 ± 6 %	5.09 mho/m ± 6 %
Head TSL temperature change during test	< 0.5 °C	----	----

SAR result with Head TSL at 5600 MHz

SAR averaged over 1 cm ³ (1 g) of Head TSL	Condition	
SAR measured	100 mW input power	8.35 W/kg
SAR for nominal Head TSL parameters	normalized to 1W	83.6 W/kg ± 19.9 % (k=2)

SAR averaged over 10 cm ³ (10 g) of Head TSL	condition	
SAR measured	100 mW input power	2.38 W/kg
SAR for nominal Head TSL parameters	normalized to 1W	23.8 W/kg ± 19.5 % (k=2)

Head TSL parameters at 5800 MHz

The following parameters and calculations were applied.

	Temperature	Permittivity	Conductivity
Nominal Head TSL parameters	22.0 °C	35.3	5.27 mho/m
Measured Head TSL parameters	(22.0 ± 0.2) °C	35.3 ± 6 %	5.24 mho/m ± 6 %
Head TSL temperature change during test	< 0.5 °C	----	----

SAR result with Head TSL at 5800 MHz

SAR averaged over 1 cm ³ (1 g) of Head TSL	Condition	
SAR measured	100 mW input power	8.14 W/kg
SAR for nominal Head TSL parameters	normalized to 1W	81.4 W/kg ± 19.9 % (k=2)

SAR averaged over 10 cm ³ (10 g) of Head TSL	condition	
SAR measured	100 mW input power	2.30 W/kg
SAR for nominal Head TSL parameters	normalized to 1W	23.0 W/kg ± 19.5 % (k=2)

Appendix (Additional assessments outside the scope of SCS 0108)

Antenna Parameters with Head TSL at 5250 MHz

Impedance, transformed to feed point	45.8 Ω - 4.5 jΩ
Return Loss	- 23.8 dB

Antenna Parameters with Head TSL at 5600 MHz

Impedance, transformed to feed point	49.4 Ω + 1.5 jΩ
Return Loss	- 35.9 dB

Antenna Parameters with Head TSL at 5800 MHz

Impedance, transformed to feed point	54.2 Ω + 1.5 jΩ
Return Loss	- 27.3 dB

General Antenna Parameters and Design

Electrical Delay (one direction)	1.189 ns
----------------------------------	----------

After long term use with 100W radiated power, only a slight warming of the dipole near the feedpoint can be measured.

The dipole is made of standard semirigid coaxial cable. The center conductor of the feeding line is directly connected to the second arm of the dipole. The antenna is therefore short-circuited for DC-signals. On some of the dipoles, small end caps are added to the dipole arms in order to improve matching when loaded according to the position as explained in the "Measurement Conditions" paragraph. The SAR data are not affected by this change. The overall dipole length is still according to the Standard.

No excessive force must be applied to the dipole arms, because they might bend or the soldered connections near the feedpoint may be damaged.

Additional EUT Data

Manufactured by	SPEAG
-----------------	-------

DASY5 Validation Report for Head TSL

Date: 27.03.2023

Test Laboratory: SPEAG, Zurich, Switzerland

DUT: Dipole D5GHzV2; Type: D5GHzV2; Serial: D5GHzV2 - SN:1374

Communication System: UID 0 - CW; Frequency: 5250 MHz, Frequency: 5600 MHz, Frequency: 5800 MHz

Medium parameters used: $f = 5250$ MHz; $\sigma = 4.71$ S/m; $\epsilon_r = 35.8$; $\rho = 1000$ kg/m³Medium parameters used: $f = 5600$ MHz; $\sigma = 5.09$ S/m; $\epsilon_r = 35.6$; $\rho = 1000$ kg/m³Medium parameters used: $f = 5800$ MHz; $\sigma = 5.24$ S/m; $\epsilon_r = 35.3$; $\rho = 1000$ kg/m³

Phantom section: Flat Section

Measurement Standard: DASY5 (IEEE/IEC/ANSI C63.19-2011)

DASY52 Configuration:

- Probe: EX3DV4 - SN3503; ConvF(5.5, 5.5, 5.5) @ 5250 MHz, ConvF(5.1, 5.1, 5.1) @ 5600 MHz, ConvF(5.01, 5.01, 5.01) @ 5800 MHz; Calibrated: 07.03.2023
- Sensor-Surface: 1.4mm (Mechanical Surface Detection)
- Electronics: DAE4 Sn601; Calibrated: 19.12.2022
- Phantom: Flat Phantom 5.0 (front); Type: QD 000 P50 AA; Serial: 1001
- DASY52 52.10.4(1535); SEMCAD X 14.6.14(7501)

Dipole Calibration for Head Tissue/Pin=100mW, dist=10mm, f=5250 MHz/Zoom Scan,**dist=1.4mm (8x8x7)/Cube 0:** Measurement grid: dx=4mm, dy=4mm, dz=1.4mm

Reference Value = 76.14 V/m; Power Drift = 0.01 dB

Peak SAR (extrapolated) = 26.9 W/kg

SAR(1 g) = 8.01 W/kg; SAR(10 g) = 2.31 W/kg

Smallest distance from peaks to all points 3 dB below = 7.2 mm

Ratio of SAR at M2 to SAR at M1 = 71.4%

Maximum value of SAR (measured) = 17.8 W/kg

Dipole Calibration for Head Tissue/Pin=100mW, dist=10mm, f=5600 MHz/Zoom Scan,**dist=1.4mm (8x8x7)/Cube 0:** Measurement grid: dx=4mm, dy=4mm, dz=1.4mm

Reference Value = 75.28 V/m; Power Drift = 0.02 dB

Peak SAR (extrapolated) = 30.3 W/kg

SAR(1 g) = 8.35 W/kg; SAR(10 g) = 2.38 W/kg

Smallest distance from peaks to all points 3 dB below = 7.2 mm

Ratio of SAR at M2 to SAR at M1 = 68.8%

Maximum value of SAR (measured) = 19.2 W/kg

Dipole Calibration for Head Tissue/Pin=100mW, dist=10mm, f=5800 MHz/Zoom Scan, dist=1.4mm (8x8x7)/Cube 0: Measurement grid: dx=4mm, dy=4mm, dz=1.4mm
Reference Value = 73.43 V/m; Power Drift = 0.01 dB
Peak SAR (extrapolated) = 31.6 W/kg
SAR(1 g) = 8.14 W/kg; SAR(10 g) = 2.3 W/kg
Smallest distance from peaks to all points 3 dB below = 7.2 mm
Ratio of SAR at M2 to SAR at M1 = 66.5%
Maximum value of SAR (measured) = 19.3 W/kg

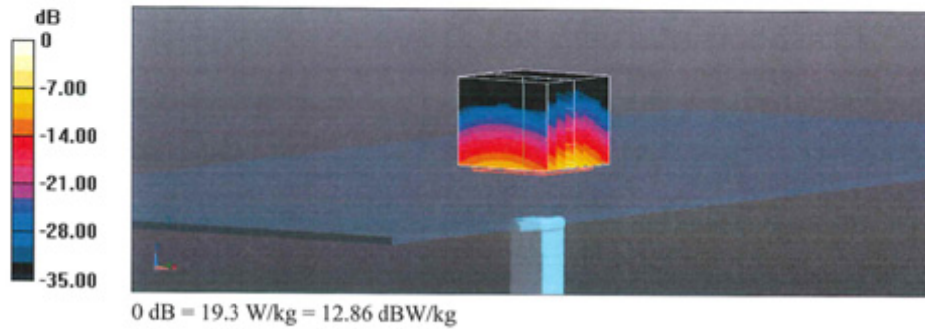

Impedance Measurement Plot for Head TSL

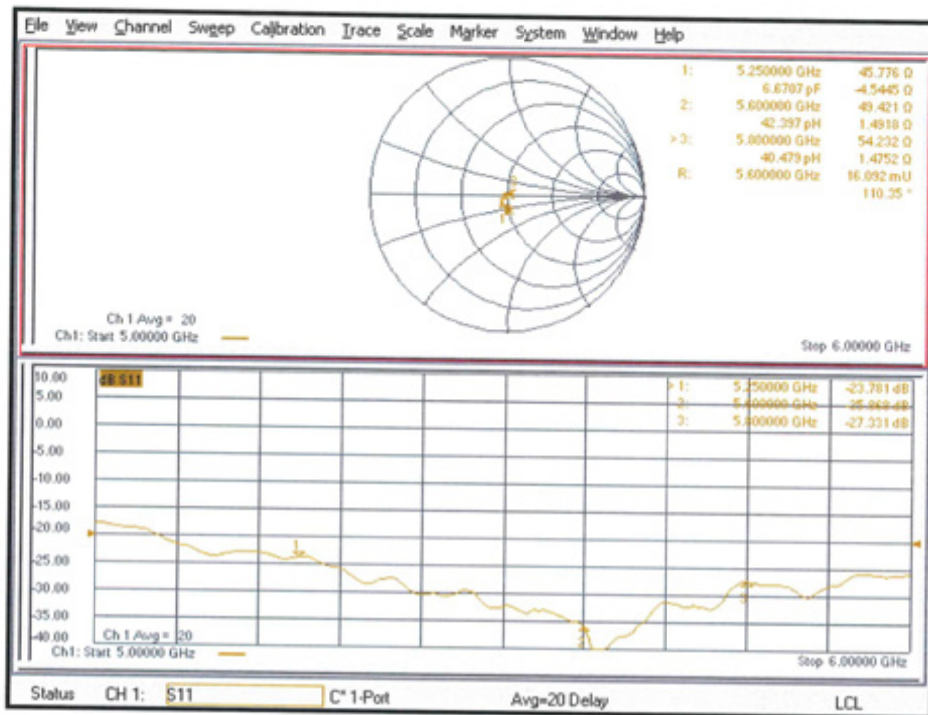

APPENDIX D EUT TEST POSITION PHOTOS

Liquid depth $\geq 15\text{cm}$

Phantom: SAM-Twin V8.0 P1aP2a; Type: QD 000 P41 AA ; Serial: 1962

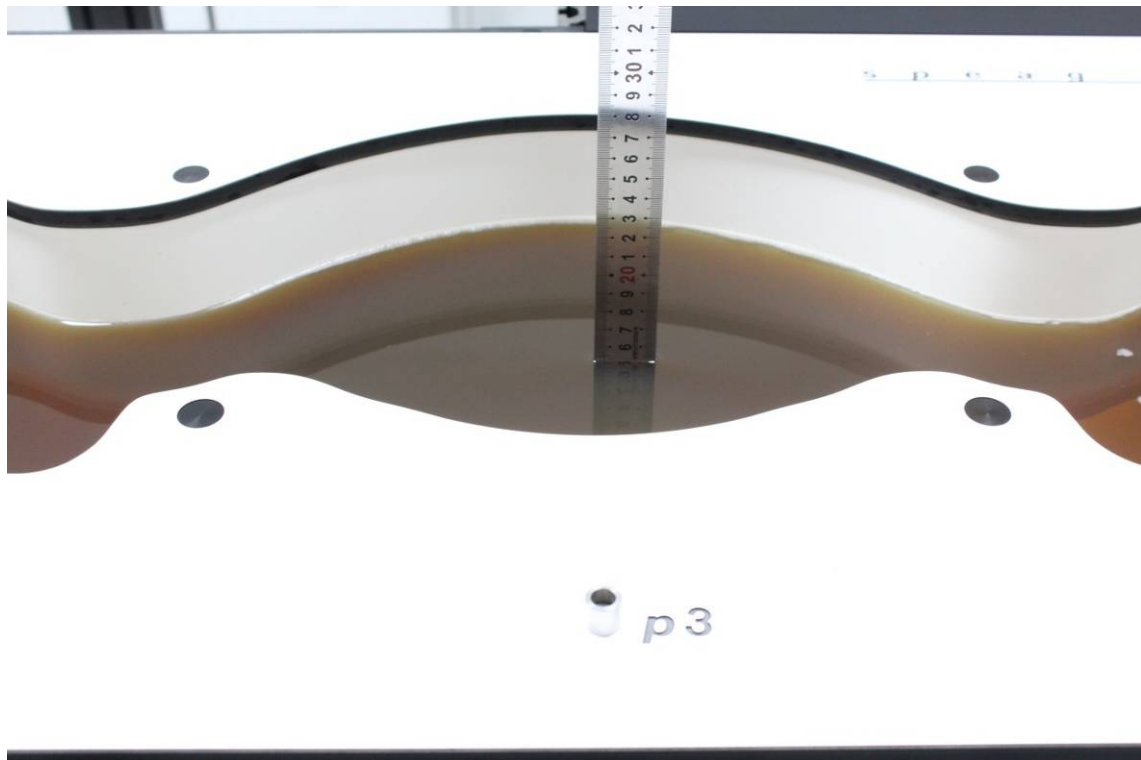

Head Left Cheek Setup Photo

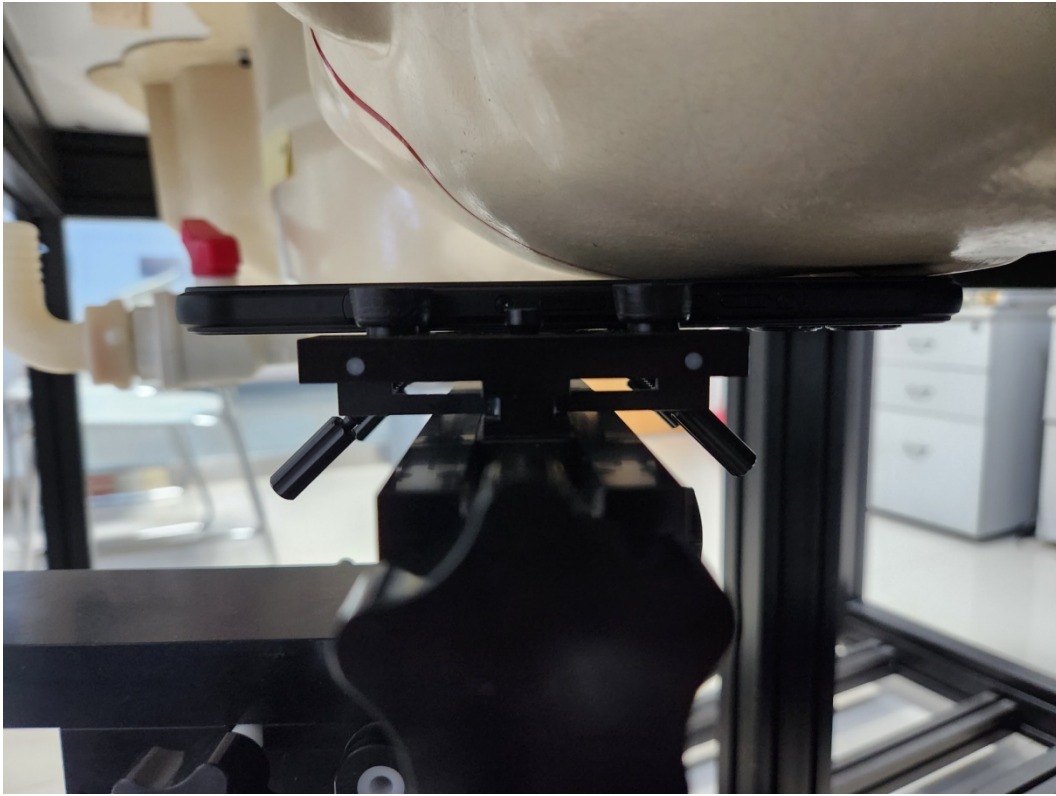

Head Left Tilt Setup Photo

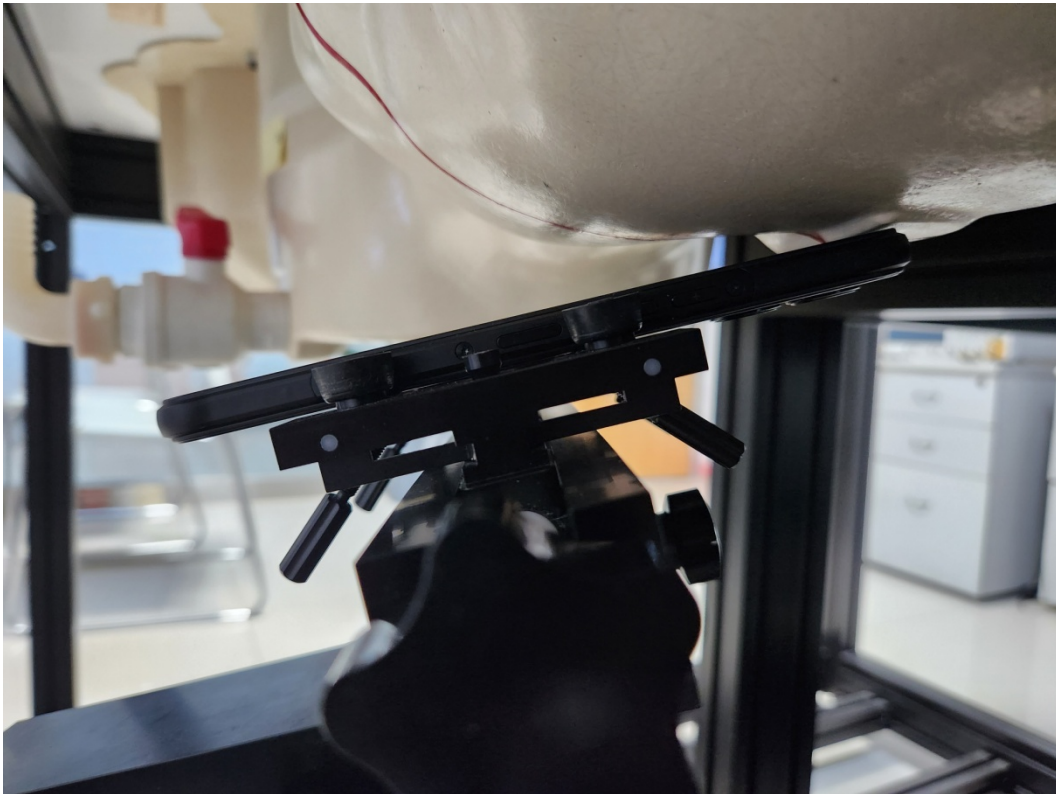

Head Right Cheek Setup Photo

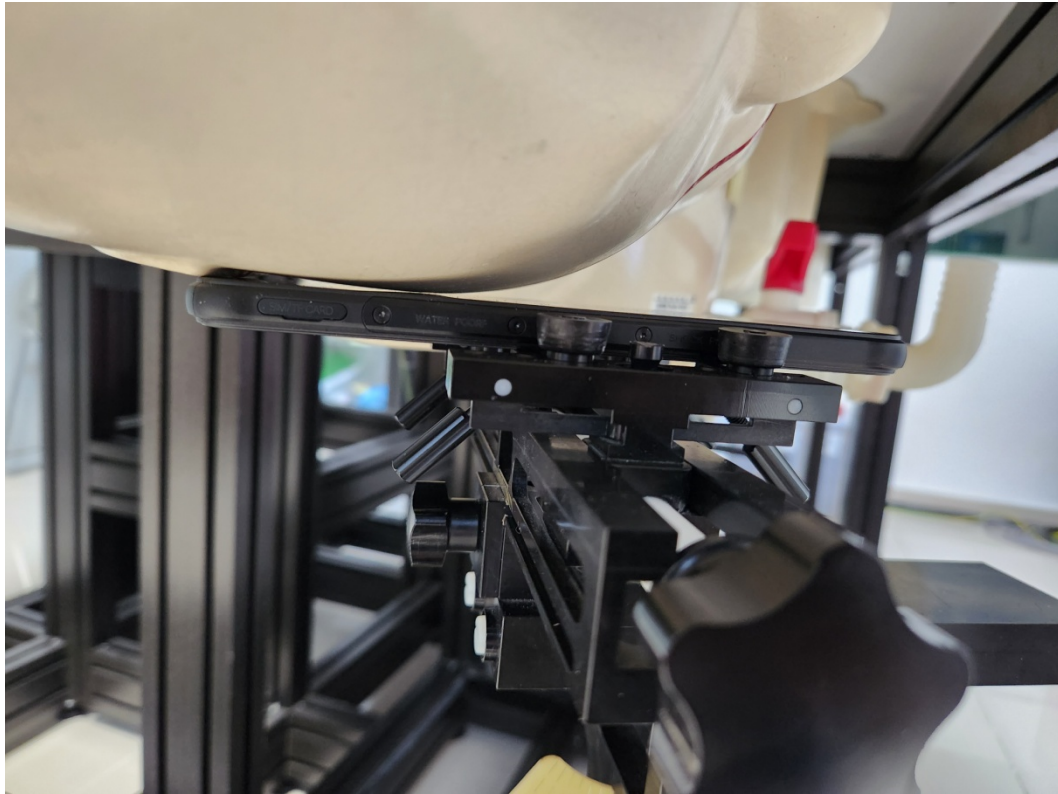

Head RightTilt Setup Photo



Body (Worn) Back Setup Photo (5 mm)



Body Front Setup Photo(5 mm)

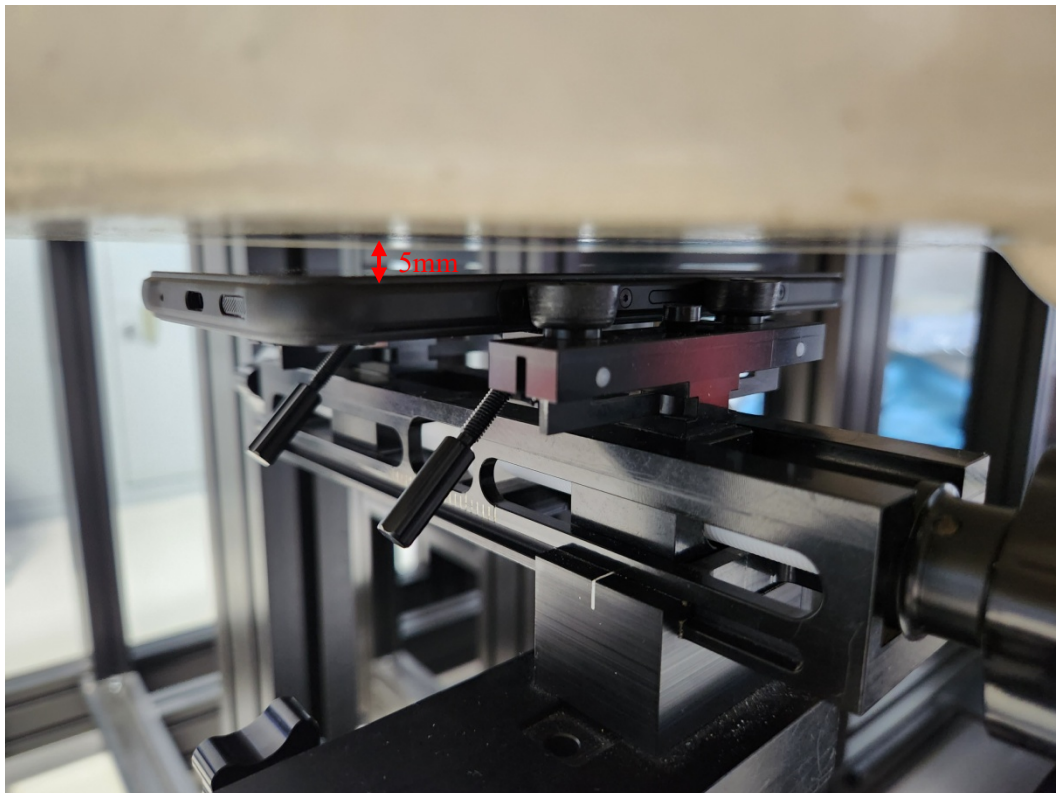

Limb Back Setup Photo (0 mm)

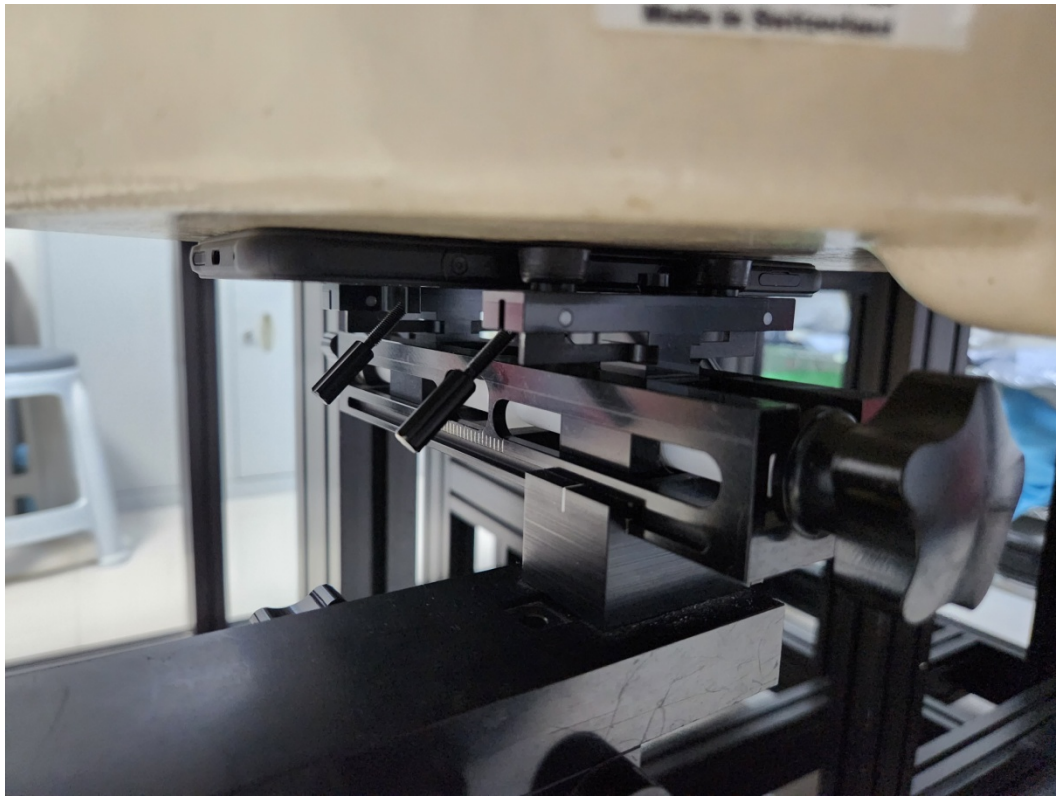

Limb Front Setup Photo(0 mm)



Limb Left Setup Photo (5 mm)

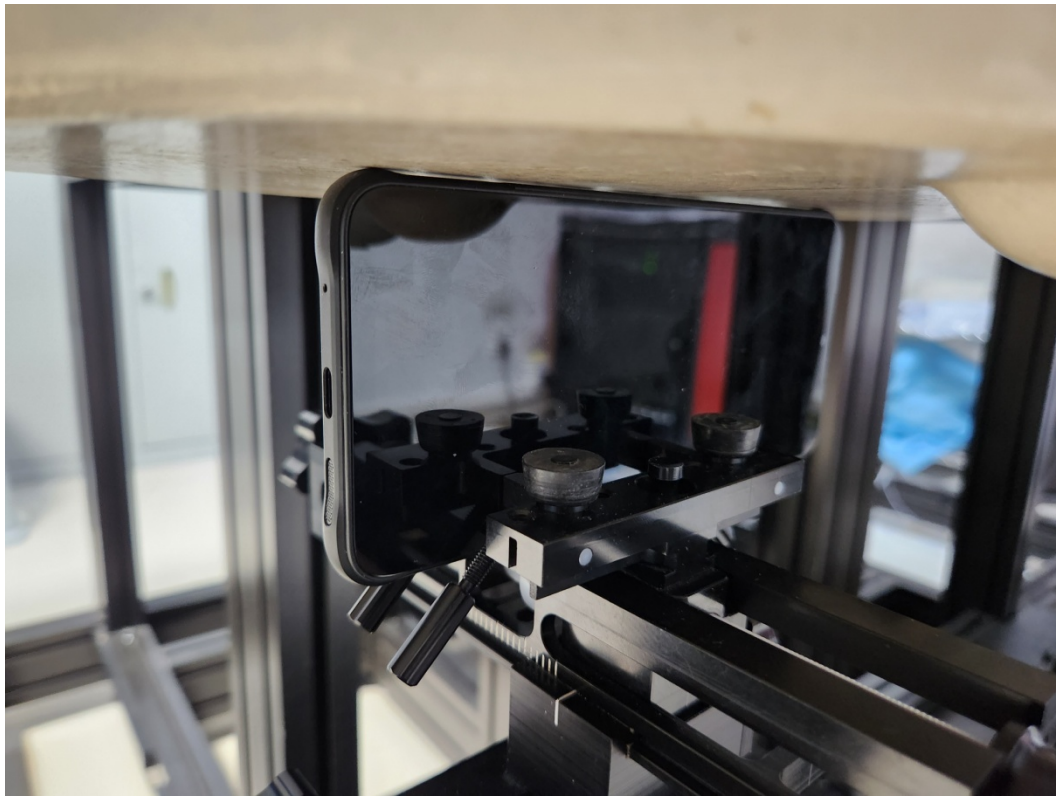

Limb Right Setup Photo(5 mm)



Limb Top Setup Photo (0 mm)

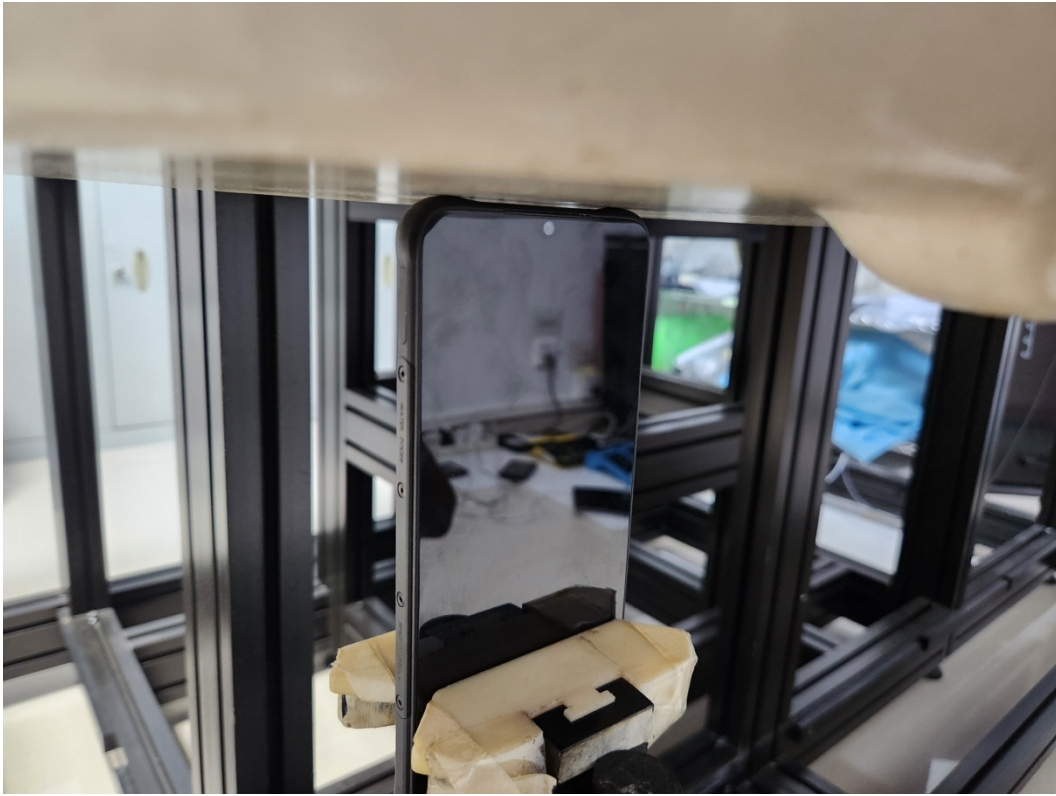

Limb Bottom Setup Photo(0 mm)

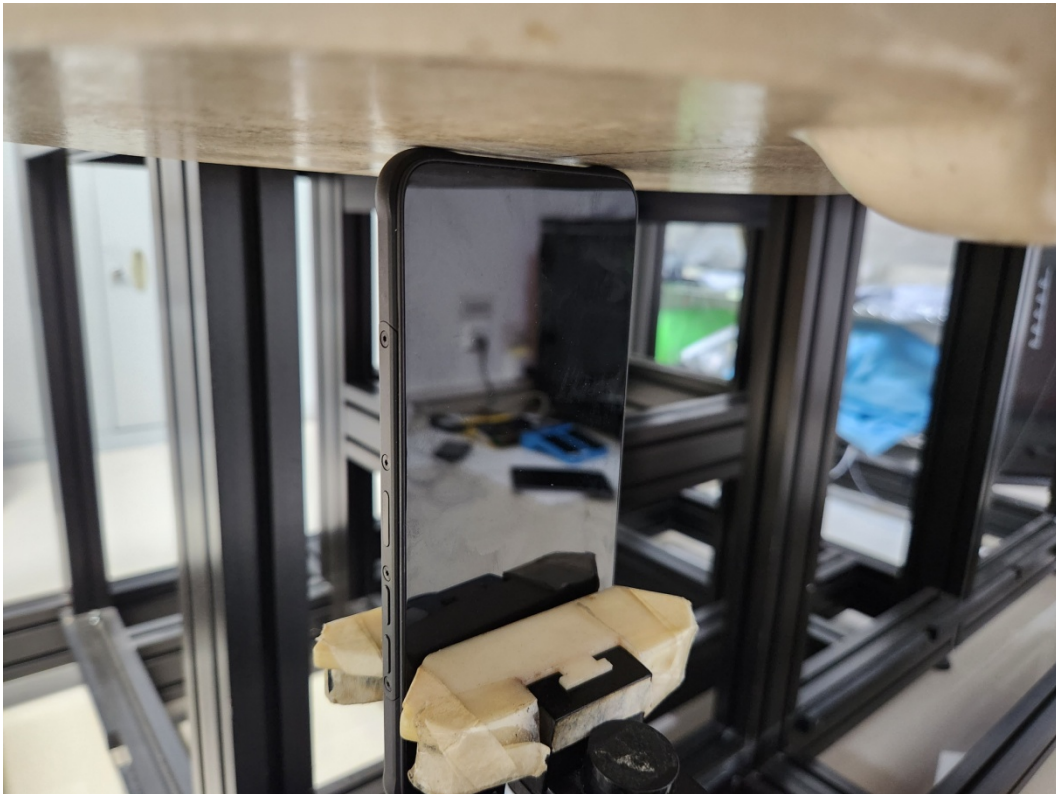

APPENDIX E EUT PHOTOS

EUT- Front View



EUT- Rear View



EUT –Main-Antenna View

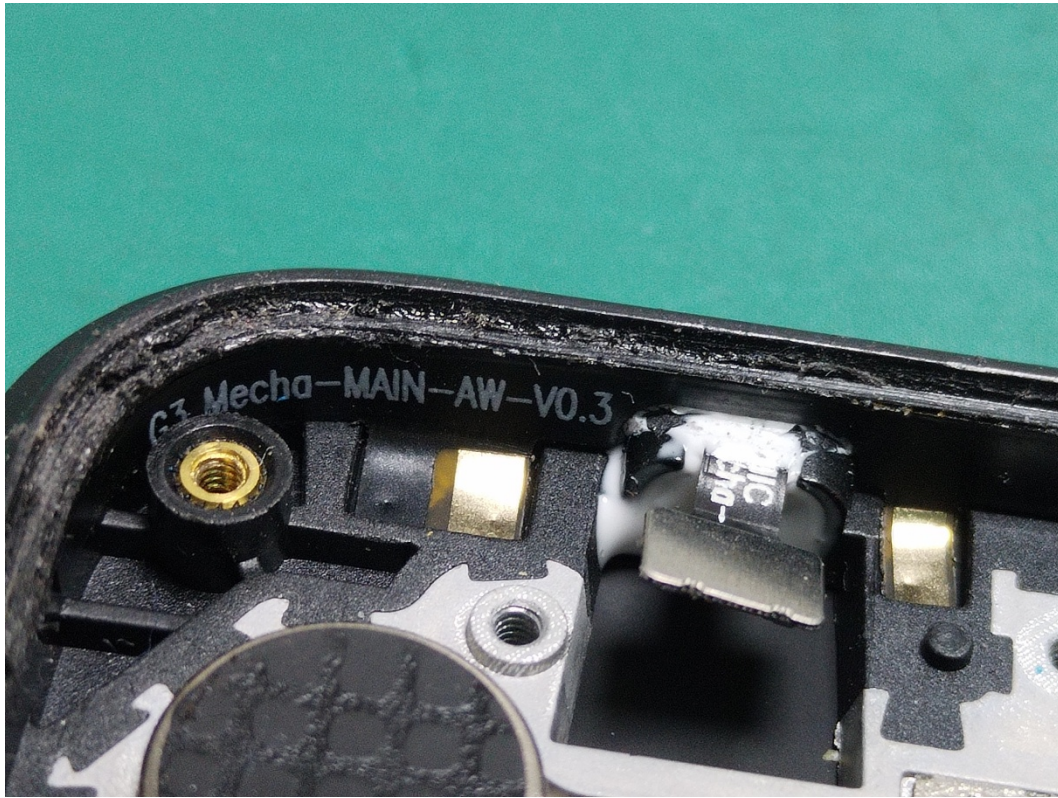

EUT –DIV-Antenna View



EUT – 2.4GWIFI&BT- Antenna View

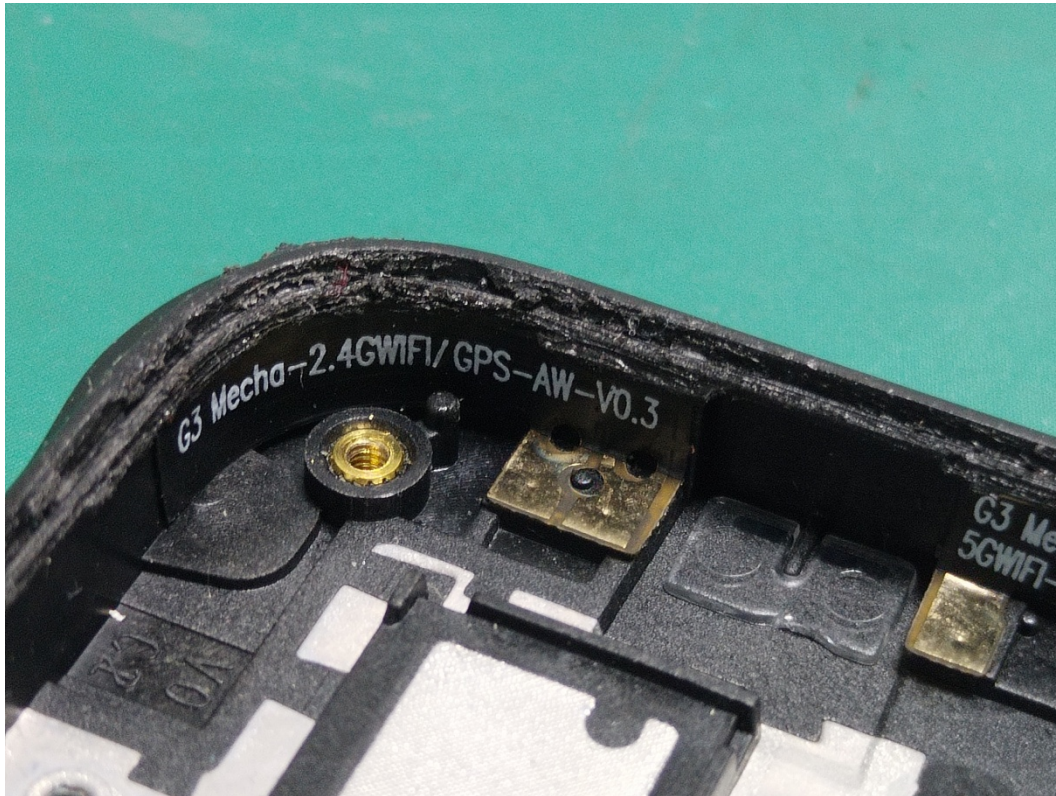

EUT – 5GWIFI - Antenna View



APPENDIX F INFORMATIVE REFERENCES

- [1] Federal Communications Commission, "Report and order: Guidelines for evaluating the environmental effects of radiofrequency radiation", Tech. Rep. FCC 96-326, FCC, Washington, D.C.20554, 1996.
- [2] David L. Means Kwok Chan, Robert F. Cleveland, "Evaluating compliance with FCC guidelines for human exposure to radiofrequency electromagnetic fields", Tech. Rep., Federal Communication Commission, Office of Engineering & Technology, Washington, DC, 1997.
- [3] Thomas Schmid, Oliver Egger, and NielsKuster, "Automated E-field scanning system for dosimetric assessments", IEEE Transactions on Microwave Theory and Techniques, vol. 44, pp. 105-113, Jan. 1996.
- [4] NielsKuster, Ralph Kastle, and Thomas Schmid, "Dosimetric evaluation of mobile communications equipment with known precision", IEEE Transactions on Communications, vol. E80-B, no. 5, pp. 645-652, May 1997.
- [5] CENELEC, "Considerations for evaluating of human exposure to electromagnetic fields (EMFs) from mobile telecommunication equipment (MTE) in the frequency range 30MHz - 6GHz", Tech. Rep., CENELEC, European Committee for Electrotechnical Standardization, Brussels, 1997.
- [6] ANSI, ANSI/IEEE C95.1-1992: IEEE Standard for Safety Levels with Respect to Human Exposure to Radio Frequency Electromagnetic Fields, 3 kHz to 300 GHz, The Institute of Electrical and Electronics Engineers, Inc., New York, NY 10017, 1992.
- [7] KatjaPokovic, Thomas Schmid, and NielsKuster, "Robust setup for precise calibration of E-field probes in tissue simulating liquids at mobile communications frequencies", in ICECOM '97, Dubrovnik, October 15-17, 1997, pp. 120-24.
- [8] KatjaPokovic, Thomas Schmid, and NielsKuster, "E-field probe with improved isotropy in brain simulating liquids", in Proceedings of the ELMAR, Zadar, Croatia, 23-25 June, 1996, pp. 172-175.
- [9] Volker Hombach, Klaus Meier, Michael Burkhardt, Eberhard Kuhn, and NielsKuster, "The dependence of EM energy absorption upon human head modeling at 900 MHz", IEEE Transactions on Microwave Theory and Techniques, vol. 44, no. 10, pp. 1865-1873, Oct. 1996.
- [10] Klaus Meier, Ralf Kastle, Volker Hombach, Roger Tay, and NielsKuster, "The dependence of EM energy absorption upon human head modeling at 1800 MHz", IEEE Transactions on Microwave Theory and Techniques, Oct. 1997, in press.
- [11] W. Gander, Computermathematik, Birkhaeuser, Basel, 1992.
- [12] W. H. Press, S. A. Teukolsky, W. T. Vetterling, and B. P. Flannery, Numerical Recipes in C, The Art of Scientific Computing, Second Edition, Cambridge University Press, 1992. Dosimetric Evaluation of Sample device, month 1998 9
- [13] NIS81 NAMAS, "The treatment of uncertainty in EMC measurement", Tech. Rep., NAMAS Executive, National Physical Laboratory, Teddington, Middlesex, England, 1994.
- [14] Barry N. Taylor and Christ E. Kuyatt, "Guidelines for evaluating and expressing the uncertainty of NIST measurement results", Tech. Rep., National Institute of Standards and Technology, 1994. Dosimetric Evaluation of Sample device, month 1998 10.

***** END OF REPORT *****