

EMC TEST REPORT

Equipment Portable DIY Power Bank Battery Box
Trademark 博续 Boxu , POWER BANK
Model No. M08, M06, M06A, M06C, M08B, M08C, M09, M09B, M09C, H02, H02B, H02C, H08, H08B, H08C
Report No. CTB210407020EX
Applicant Shenzhen Pincheng Lianchuang Technology Co., Ltd.
6th Floor, Building B3, HeKan Industrial Park, No. 41, WuHe South Road, BanTian Street, LongGang District, Shenzhen
Manufacturer Shenzhen Pincheng Lianchuang Technology Co., Ltd.
6th Floor, Building B3, HeKan Industrial Park, No. 41, WuHe South Road, BanTian Street, LongGang District, Shenzhen
Prepared by Shenzhen CTB Testing Technology Co., Ltd.
Floor 1&2, Building A, No. 26 of Xinhe Road, Xinqiao Street, Baoan District, Shenzhen China
Tel: 4008-707-283
Fax: 086-0755-23208027
Date of Receipt Mar. 31, 2021
Date of Test(s) Mar. 31, 2021 ~ Apr. 07, 2021
Date of Issue Apr. 07, 2021
Test Standard(s) EN 55032:2015, EN 55035:2017/A11:2020

In the configuration tested, the EUT complied with the standards specified above.

Producer : Amy Yang , Date : Apr. 07, 2021
Amy Yang / Engineer

Signatory :  , Date : Apr. 07, 2021
Bin Mei / Director

Note: The results shown in this test report refer only to the sample(s) tested unless otherwise stated. This test report shall not be reproduced except in full, without prior written approval of CTB. This document may be altered or revised by CTB, personnel only, and shall be noted in the revision of the document.

Revision History

Edition No.	Date of Revision	Revision Summary	Report Number
0	Apr. 07, 2021	Original Report	CTB210407020EX

Table of Contents

1. TEST SUMMARY	4
2. GENERAL INFORMATION	5
2.1. Description of EUT	5
2.2. Operating condition of EUT	6
2.3. Test conditions	6
2.4. Block diagram of EUT configuration	6
3. FACILITIES	7
3.1. Test Facility	7
3.2. Test Instruments	7
5. Emission	9
5.1. Conducted Emission	9
5.2. Radiated emissions	11
5.3. Harmonic current emissions	15
5.4. Voltage changes, voltage fluctuations and flicker	16
6. Immunity	17
6.1. Electrostatic discharges (ESD)	18
6.2. Electromagnetic field	19
7. Photographs of test setup	20
8. Photographs of EUT	21

1. TEST SUMMARY

Emission			
Requirement - Test	Test Method	Limit	Result
Conducted Emission	EN 55032:2015	Class B	N/A
Radiated emissions at frequencies up to 1 GHz		Class B	PASS
Radiated emissions at frequencies above 1 GHz		Class B	N/A
Harmonic current emissions	EN IEC 61000-3-2:2019	Class A	N/A
Voltage changes, voltage fluctuations and flicker	EN 61000-3-3:2013/A1:2019	Clause 5	N/A
Immunity (EN 55035:2017)			
Requirement - Test	Test Method	Performance criteria	Result
Electrostatic discharges (ESD)	EN 61000-4-2:2009	B	PASS
Electromagnetic field	EN 61000-4-3:2006+A1:2008+A2:2010	A	PASS
Electrical fast transients/burst (EFT/B)	EN 61000-4-4:2004+A1:2010	B	N/A
Surges	EN 61000-4-5:2006	B	N/A
Conducted RF	EN 61000-4-6:2009	A	N/A
Power frequency magnetic field	EN 61000-4-8:2010	A	N/A
Voltage dips and Short interruptions	EN 61000-4-11:2009+A1:2010	B & C	N/A

Remark: N/A is abbreviation for Not Applicable.

The test was carried out in all the test modes, only the worst data are list in report.

2. GENERAL INFORMATION

2.1. Description of EUT

Equipment	Portable DIY Power Bank Battery Box
Trademark	博续 Boxu , POWER BANK
Model Name	M08,
Serial No.	M06, M06A, M06C, M08B, M08C, M09, M09B, M09C, H02, H02B, H02C, H08, H08B, H08C
Model Difference	All model's the function, software and electric circuit are the same, only with a product color and model named different. Test sample model: M08,
Rated Power Supply	Input: DC 5V, 2A Output:5V/1A, 5V/ 2A
Rated Power	/
Normal Testing Voltage	Input: DC 5V, 2A Output:5V/1A, 5V/ 2A
Configuration	<input checked="" type="checkbox"/> Table-top <input type="checkbox"/> Floor-standing
Accessory Device	Adpater
Cable Supplied	USB cable ,

Note:

1. Other Accessory Device List and Details

Description	Manufacturer	Model	Note
			-

External I/O Cable

Cable Description	Shielded Type	Ferrite Core	Length(m)	Note
-	<input type="checkbox"/> Shielded <input type="checkbox"/> Non-shielded	<input type="checkbox"/> Yes <input type="checkbox"/> No		

2. The above EUT information is declared by manufacturer and for more detailed features description, please refer to the manufacturer's specifications or the User's Manual.

2.2. Operating condition of EUT

To investigate the maximum EMI emission characteristics generates from EUT, the test system was pre-scanning tested base on the consideration of following EUT operation mode or test configuration mode which possible have effect on EMI emission level. Each of these EUT operation mode(s) or test configuration mode(s) mentioned above was evaluated respectively

Pretest Mode	Description
Mode 1	Working

For Conducted Test	
Final Test Mode	Description
Mode 1	Working
Mode 2	charge

For Radiated Test	
Final Test Mode	Description
Mode 1	Working
Mode 2	charge

2.3. Test conditions

Temperature: 15-35°C

Relative Humidity: 30-60 %

Atmospheric pressure: 800hPa-1060hPa

2.4. Block diagram of EUT configuration

Working

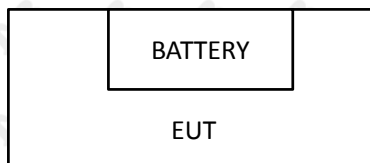

Charge



3. FACILITIES

3.1. Test Facility

CTB-LAB

Floor 1&2, Building A, No. 26 of Xinhe Road, Xinqiao Street, Baoan District, Shenzhen China

3.2. Test Instruments

Radiated Emission Measurement (Test software: EZ-EMC Ver. FA-03A2 RE)

Item	Equipment	Manufacturer	Model No.	Serial No.	Calibrated until
1	Double Ridged Broadband Horn Antenna	Schwarzbeck	BBHA 9120D	1911	2021.11.02
2	TRILOG Broadband Antenna	Schwarzbeck	VULB 9168	869	2021.11.02
3	Amplifier	Agilent	8449B	3008A01838	2021.11.01
4	Amplifier	HP	8447E	2945A02747	2021.11.01
5	EMI TEST RECEIVER	ROHDE&SCHWARZ	ESPI7	100362	2021.11.01
6	Coaxial cable	ETS	RFC-SNS-100-NMS-80 NI	/	2021.11.01
7	Coaxial cable	ETS	RFC-SNS-100-NMS-20 NI	/	2021.11.01
8	Coaxial cable	ETS	RFC-SNS-100-SMS-20 NI	/	2021.11.01
9	Coaxial cable	ETS	RFC-NNS-100-NMS-300 NI	/	2021.11.01

Electrostatic Discharge Test

Item	Equipment	Manufacturer	Model No.	Serial No.	Calibrated until
1	ESD Simulator	TESTQ	NSG437	329	2021.10.30

RF electromagnetic field Test

Item	Equipment	Manufacturer	Type No.	Serial No.	Calibrated until
1	Signal Generator	Agilent	N5182A	MY47420195	2021.10.30
2	Log-Bicon Antenna	Schwarzbeck	VULB9161	9128ES-128	2021.10.30
3	Power Amplifier	AR	150W1000M1	342526	2021.10.30
4	Microwave Horn Antenna	AR	AT4002A	322279	2021.10.30
5	Power Amplifier	AR	25S1G4A	321116	2021.10.30

4. Measurement uncertainty

The following table is for the measurement uncertainty, which is calculated as per the document CISPR 16-4.

Test	Parameters	Expanded Uncertainty (U_{Lab})	Expanded Uncertainty (U_{Cispr})
Conducted Emission	Level Accuracy: 150kHz to 30MHz	± 1.22 dB	± 3.6 dB
Radiated Emission	Level Accuracy: 30MHz to 1000 MHz	± 3.67 dB	± 5.2 dB
Radiated Emission	Level Accuracy: Above 1000MHz	± 4.79 dB	N/A

This uncertainty represents an expanded uncertainty expressed at approximately the 95% confidence level using a coverage factor of $k=2$.

5. Emission

5.1. Conducted Emission

5.1.1. Limit

Requirements for conducted emissions from the AC mains power ports of Class A equipment

Frequency range MHz	Coupling device	Detector type / bandwidth	Class A limits dB(μ V)
0,15 to 0,5	AMN	Quasi Peak / 9 kHz	79
0,5 to 30			73
0,15 to 0,5		Average / 9 kHz	66
0,5 to 30			60

Requirements for conducted emissions from the AC mains power ports of Class B equipment

Frequency range MHz	Coupling device	Detector type / bandwidth	Class B limits dB(μ V)
0,15 to 0,5	AMN	Quasi Peak / 9 kHz	66 to 56
0,5 to 5			56
5 to 30			60
0,15 to 0,5		Average / 9 kHz	56 to 46
0,5 to 5			46
5 to 30			50

Requirements for asymmetric mode conducted emissions from Class A equipment

Frequency range MHz	Coupling device	Detector type / bandwidth	Class A limits dB(μ V)
0,15 to 0,5	AAN	Quasi Peak / 9 kHz	97 to 87
0,5 to 30			87
0,15 to 0,5		Average / 9 kHz	84 to 74
0,5 to 30			74

Requirements for asymmetric mode conducted emissions from Class B equipment

Frequency range MHz	Coupling device	Detector type / bandwidth	Class B limits dB(μ V)
0,15 to 0,5	AAN	Quasi Peak / 9 kHz	84 to 74
0,5 to 30			74
0,15 to 0,5		Average / 9 kHz	74 to 64
0,5 to 30			64

5.1.2. Test setup

For table-top equipment

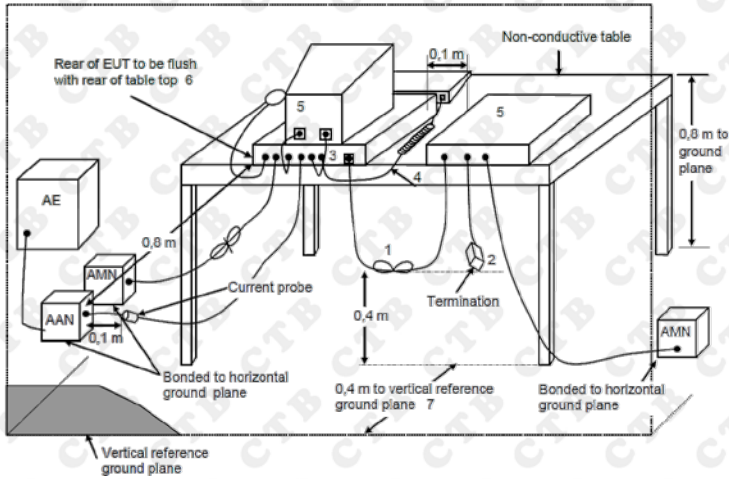

For floor standing equipment

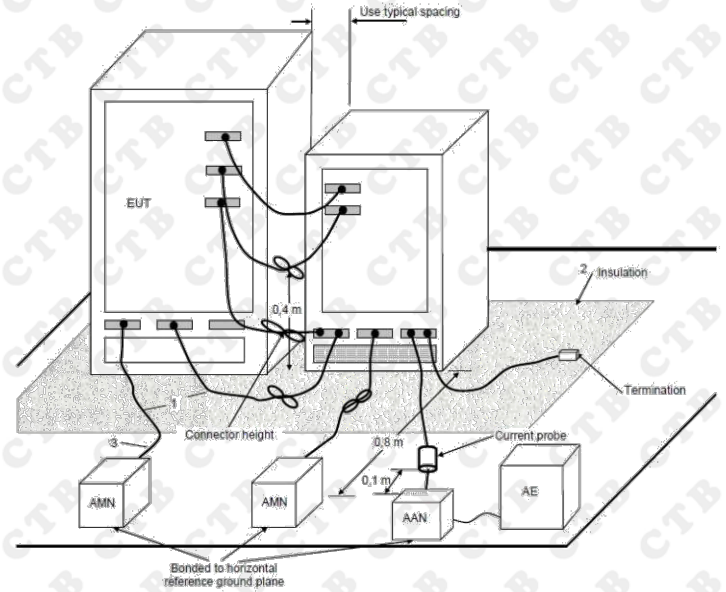

5.1.3. Test procedure

Measurement was performed in shielded room, and instruments used were followed CISPR 16-2-1 clause 7.

Detailed test procedure was following clause 7 of CISPR 16-2-1.

Frequency range 150kHz – 30MHz was checked and EMI receiver measurement bandwidth was set to 9 kHz.

5.1.4. Test results

N/A

5.2. Radiated emissions

5.2.1. Limit

Requirements for radiated emissions at frequencies up to 1 GHz for class A equipment

Frequency range MHz	Measurement			Class B limits dB(μ V/m)
	Facility	Distance m	Detector type / bandwidth	
30 to 230	SAC	3	Quasi Peak / 120 kHz	50
230 to 1 000				57

Requirements for radiated emissions at frequencies above 1 GHz for class A equipment

Frequency range MHz	Measurement			Class B limits dB(μ V/m)
	Facility	Distance m	Detector type / bandwidth	
1 000 to 3 000	FSOATS	3	Average / 1MHz	56
3 000 to 6 000				60
1 000 to 3 000		3	Average / 1MHz	76
3 000 to 6 000				80

Requirements for radiated emissions at frequencies up to 1 GHz for class B equipment

Frequency range MHz	Measurement			Class B limits dB(μ V/m)
	Facility	Distance m	Detector type / bandwidth	
30 to 230	SAC	3	Quasi Peak / 120 kHz	40
230 to 1 000				47

Requirements for radiated emissions at frequencies above 1 GHz for class B equipment

Frequency range MHz	Measurement			Class B limits dB(μ V/m)
	Facility	Distance m	Detector type / bandwidth	
1 000 to 3 000	FSOATS	3	Average / 1MHz	50
3 000 to 6 000				54
1 000 to 3 000		3	Average / 1MHz	70
3 000 to 6 000				74

5.2.2. Block diagram of test setup

Measurement distance

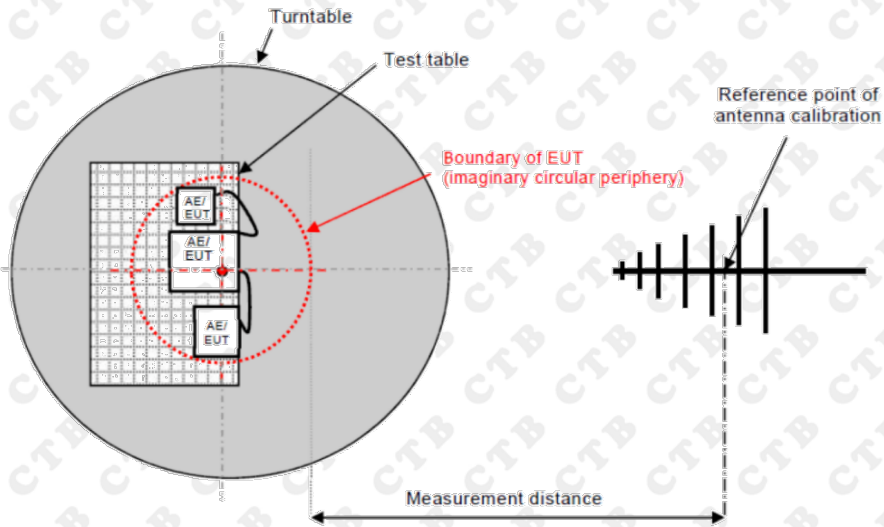

For table-top equipment

For floor standing equipment

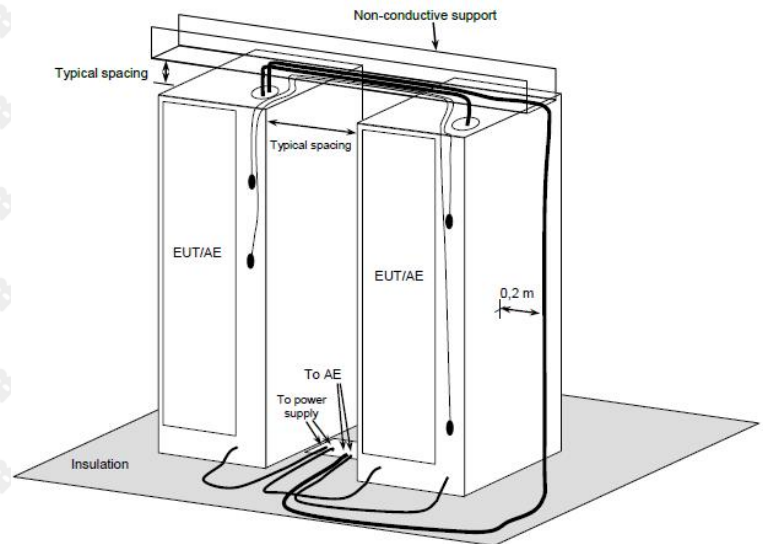
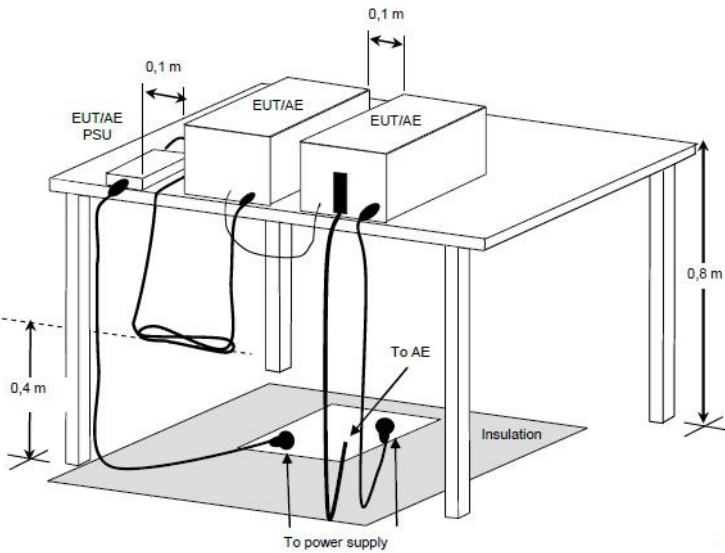

5.2.3. Test procedure

The measurement was performed in a semi-anechoic chamber. The distance from EUT to receiving antenna is 3 meters. Measurement was performed according to clause 7.3 of CISPR 16-2-3.

5.2.4. Test results

PASS

Please refer to the following page.

Polarization: H

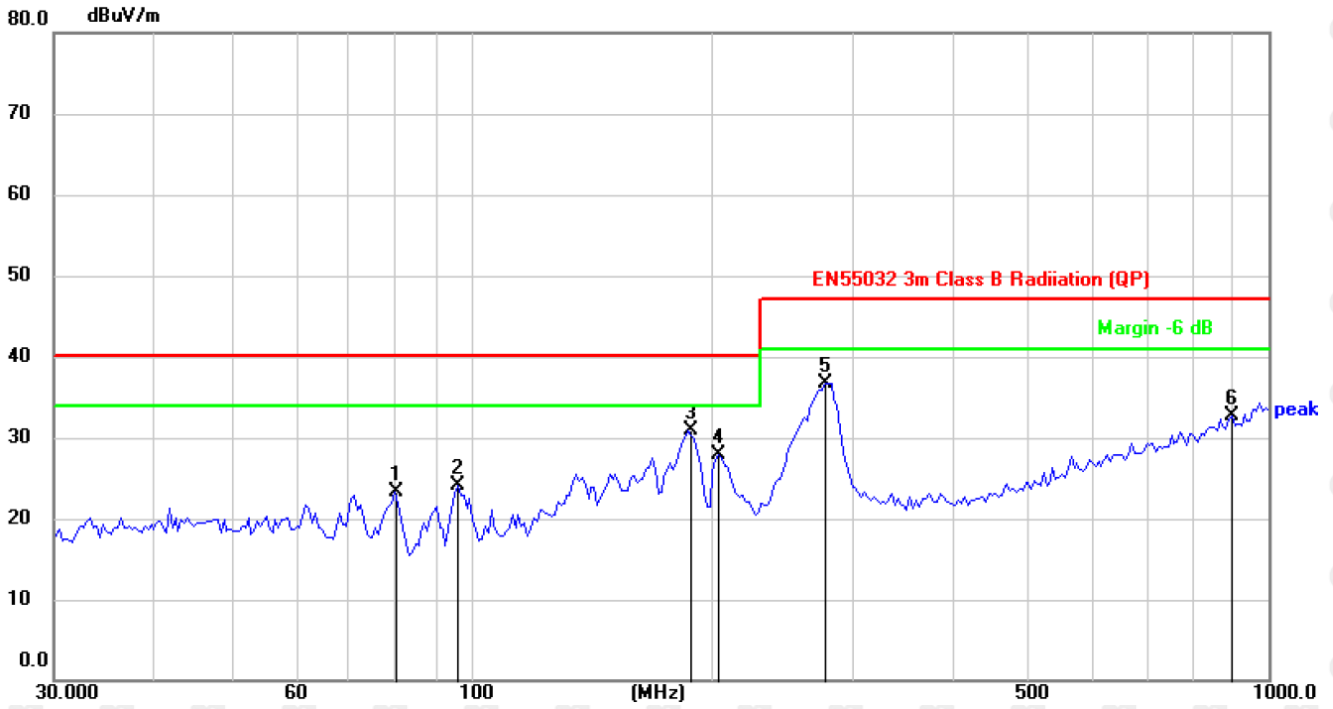

No.	Mk.	Freq. MHz	Reading Level dBuV	Correct Factor dB	Measure- ment dBuV/m	Limit dB/m	Over dB	Antenna Height cm	Table Degree degree	Comment
1		80.0806	34.98	-11.58	23.40	40.00	-16.60	QP		
2		96.2672	34.91	-10.72	24.19	40.00	-15.81	QP		
3	*	187.4241	40.23	-9.39	30.84	40.00	-9.16	QP		
4		204.5961	38.02	-10.20	27.82	40.00	-12.18	QP		
5		278.0668	44.40	-7.60	36.80	47.00	-10.20	QP		
6		900.1474	27.05	5.60	32.65	47.00	-14.35	QP		

Note: Result=Reading+Factor
Over Limit=Result-Limit

Polarization: V

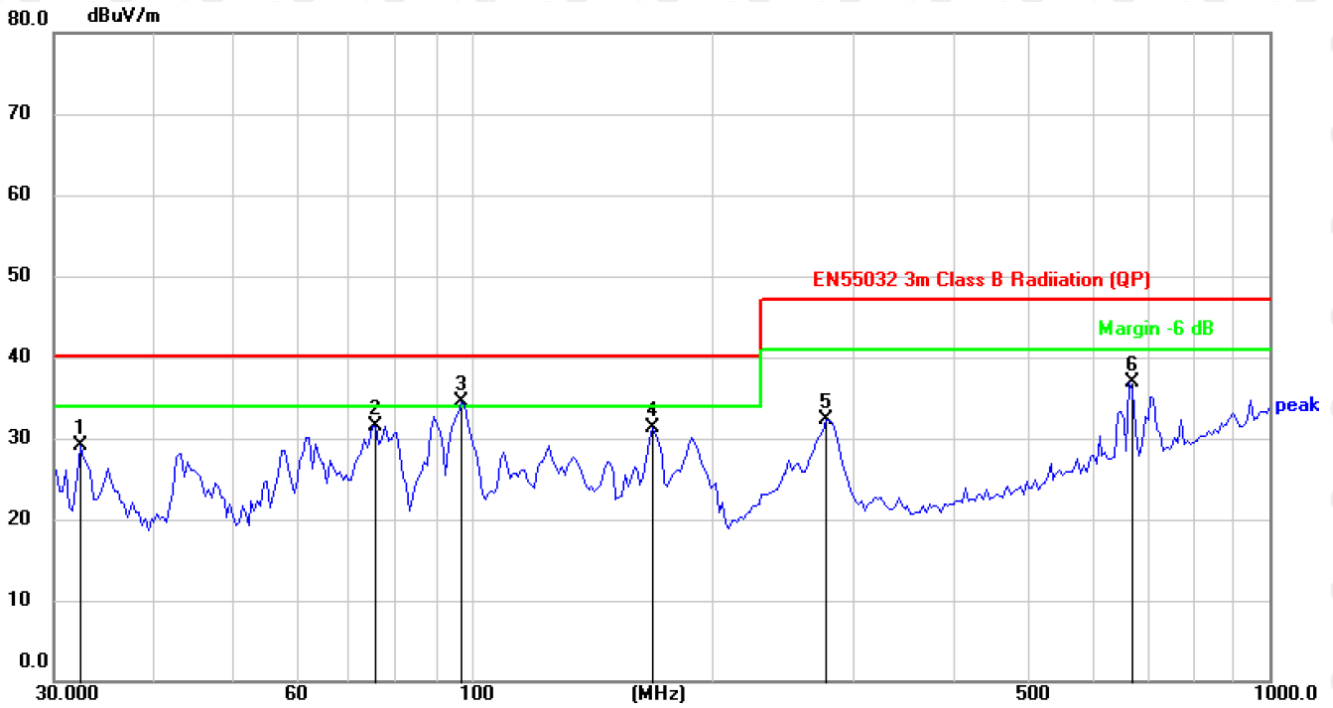

No.	Mk.	Freq. MHz	Reading Level dBuV	Correct Factor dB	Measure- ment dBuV/m	Limit dB/m	Over dB	Antenna Height cm	Table Degree degree	Comment
1		32.4628	36.97	-7.85	29.12	40.00	-10.88	QP		
2		75.9773	42.40	-10.86	31.54	40.00	-8.46	QP		
3	*	97.1148	45.17	-10.65	34.52	40.00	-5.48	QP		
4		168.7093	39.14	-7.78	31.36	40.00	-8.64	QP		
5		278.0668	39.91	-7.60	32.31	47.00	-14.69	QP		
6		668.1423	35.14	1.75	36.89	47.00	-10.11	QP		

Note: Result=Reading+Factor
Over Limit=Result-Limit

5.3. Harmonic current emissions

5.3.1. Test Setup

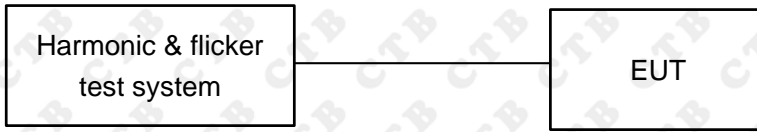

5.3.2. Test Procedure

Basic Standard(s)	: EN IEC 61000-3-2:2019
Measurement Equipment requirement	: IEC 61000-4-7
Measured Harmonics	: 1 - 40
Equipment Class	: <input type="checkbox"/> A <input type="checkbox"/> B <input type="checkbox"/> C <input type="checkbox"/> D
Limits	: <input type="checkbox"/> Clause 7.1 Table 1 <input type="checkbox"/> Clause 7.2 <input type="checkbox"/> Clause 7.3 Table 2 <input type="checkbox"/> Clause 7.4 Table 3

- This product is not defined as lighting equipment, and has rated power less than 75W, therefore, no limit applies according to EN 61000-3-2
- The EUT is kitchen machines as listed in the scope of IEC 60335-2-14, therefore, is deemed to conform to the harmonic current limits of this standard without further testing.

5.3.3. Test Result

N/a

No adapters ,EUT not applicable to this test.

5.4. Voltage changes, voltage fluctuations and flicker

5.4.1. Test Setup



5.4.2. Test Procedure

Basic Standard(s)	: EN 61000-3-3:2013/A1:2019
Measurement Equipment requirement	: IEC 61000-4-15
Limits	: Clause 5

5.4.2.1 Definition

Flicker: impression of unsteadiness of visual sensation induced by a lighting stimulus whose luminance or spectral distribution fluctuates with time.

P_{st} : Short-term flicker indicator the flicker severity evaluated over a short period (in minutes);

$P_{st}=1$ is the conventional threshold of irritability

P_{lt} : long-term flicker indicator; the flicker severity evaluated over a long period (a few hours) using successive P_{st} values.

dc: the relative steady-state voltage change

d_{max} : the maximum relative voltage change

$d(t)$: the value during a voltage change

5.4.2.2 Test Procedure

The following limits apply

- " P_{lt} " shall not exceed 0.65.
- " P_{st} " shall not exceed 1.0.
- "dc" shall not exceed 3.3%.
- " $d(t)$ " shall not exceed 3.3% for more than 500ms.
- " d_{max} " shall not exceed:
 - 4% without additional conditions,
 - 6% switched manually or automatically more than twice per day,
 - 7% attended whilst in use or switched automatically for no more than twice per day or attended while in use.
 - For manual switch, d_{max} is measured in accordance with Annex B of standard, average d_{max} is calculated from 24 times measurement.
 - The EUT is unlikely to produce significant voltage fluctuations or flicker by technical analysis and evaluation. So it is deemed to fulfil the requirements without testing.

5.4.3. Test Result

N/a

No adapters ,EUT not applicable to this test.

6. Immunity

Performance criteria

Performance criterion A

The equipment shall continue to operate as intended without operator intervention. No degradation of performance or loss function is allowed below a performance level specified by the manufacturer, when the equipment is used as intended. The performance level may be replaced by a permissible loss of performance. If the minimum performance level or the permissible performance loss is not specified by the manufacturer, then either of these may be derived from the product description and documentation, and by what the user may reasonably expect from the equipment if used as intended.

Performance criterion B

The equipment shall continue to operate as intended after the test. No degradation of performance or loss function is allowed below a performance level specified by the manufacturer, when the equipment is used as intended. During the test, degradation of performance is however allowed. No change of actual operating state or stored data is allowed. If the minimum performance level or the permissible performance loss is specified by the manufacturer, either of these may be derived from the product description and documentation and what the user may reasonably expect from equipment if used as intended.

Performance criterion C

Temporary loss of function is allowed, provided the function is self-recoverable or can be restored by operation of the controls.

6.1. Electrostatic discharges (ESD)

6.1.1. Test Levels and Performance Criterion

Characteristics	Test levels
Air discharge	±8 kV
Contact discharge	±4 kV

Performance criterion: **B**

6.1.2. Test setup

For table-top equipment

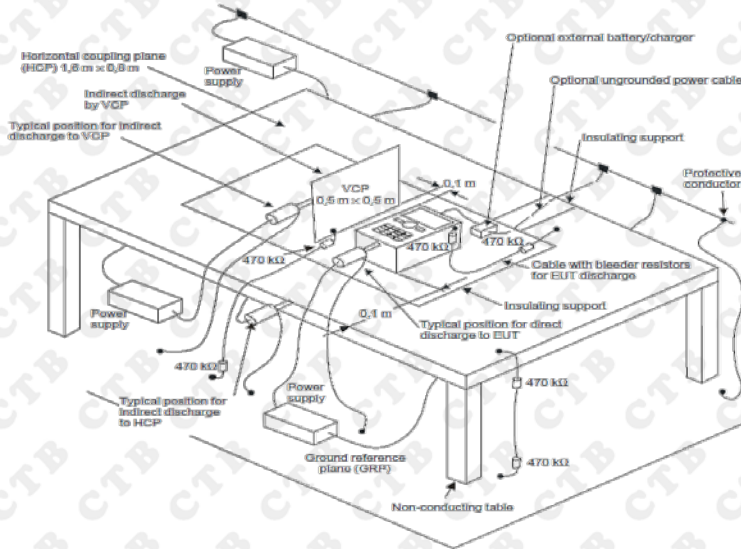

For floor standing equipment

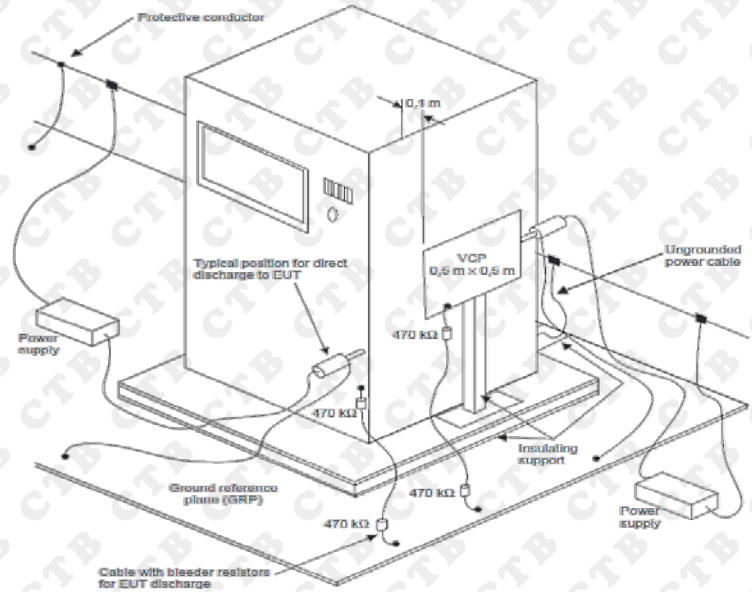

6.1.3. Test Procedure

Measurement was performed in shielded room.

Measurement procedure was applied according to EN 61000-4-2 clause 8.

The test method and equipment were specified by EN 61000-4-2.

6.1.4. Test Result

PASS

Please refer to the following page.

No.	Location of discharge	Polarity	Discharge	Number of discharges	Test level kV	Result
1	HCP	P&N	C	10	4	PASS
2	VCP	P&N	C	10	4	PASS
3	Points on conductive surface	P&N	C	10	4	PASS
4	Points on non-conductive surface	P&N	A	10	8	PASS

HCP = Horizontal coupling plate VCP = Vertical coupling plate N = Negative P = Positive
 A = Air discharge C = Contact discharge

6.2. Electromagnetic field

6.2.1. Test Levels and Performance Criterion

Characteristics	Test levels	Test levels
Frequency range	80 MHz to 1 000 MHz,	1 800MHz, 2 600MHz, 3 500MHz, 5 000MHz
Test level	3 V/m (unmodulated)	3 V/m (unmodulated)
Modulation	1 kHz, 80 % AM, sine wave	1 kHz, 80 % AM, sine wave

Performance criterion: **A**

6.2.2. Test setup

For table-top equipment

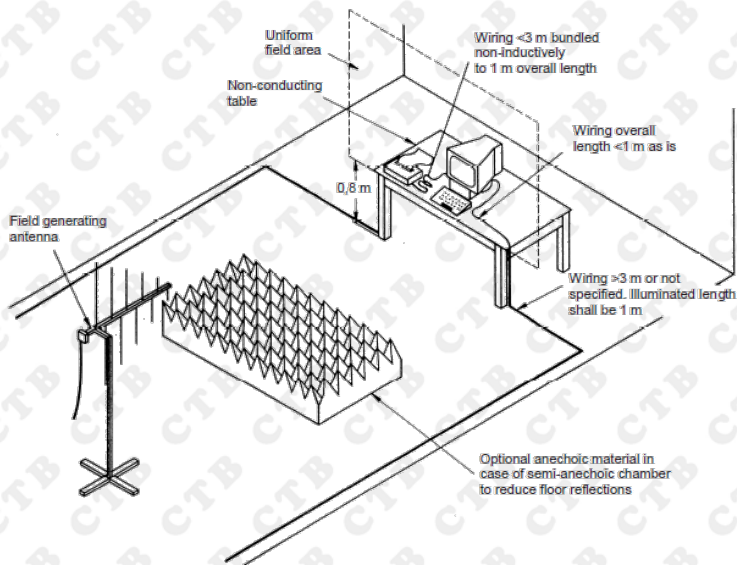

For floor standing equipment

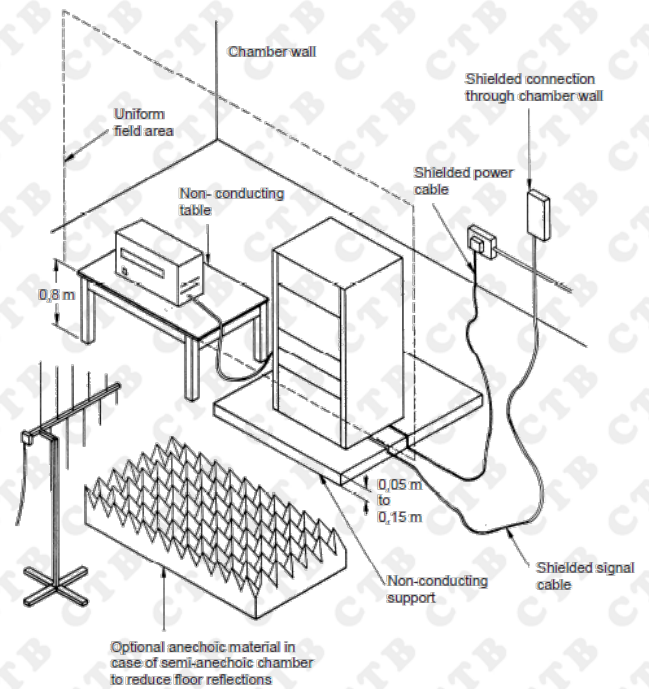

6.2.3. Test Procedure

Measurement was performed in full-anechoic chamber.

Measurement procedure was applied according to EN 61000-4-3 clause 8.

The test method and equipment was specified by EN 61000-4-3.

6.2.4. Test Result

PASS

Enclosure	Horizontal	Vertical
Front	PASS	PASS
Right Side	PASS	PASS
Left Side	PASS	PASS
Rear	PASS	PASS

7. Photographs of test setup

Photograph of test setup for Radiated Emission up to 1 GHz

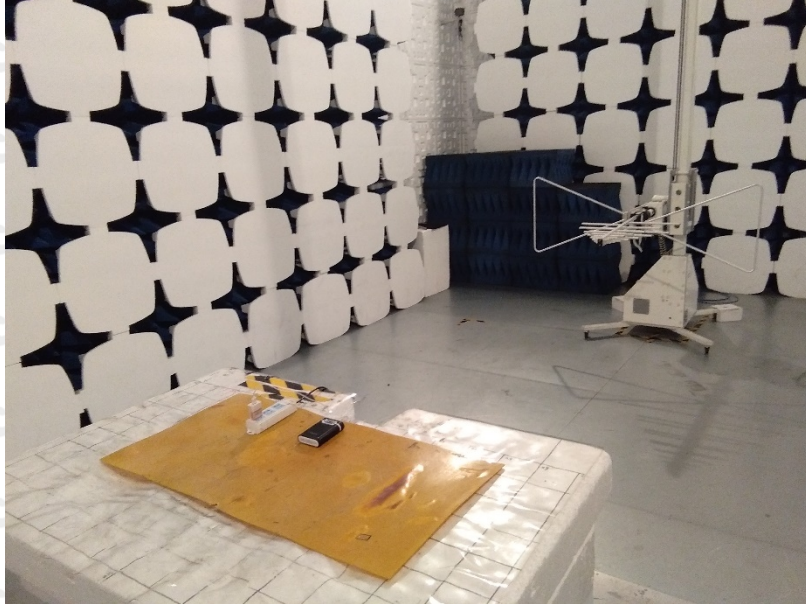

8. Photographs of EUT

Photographs of EUT



Photographs of EUT

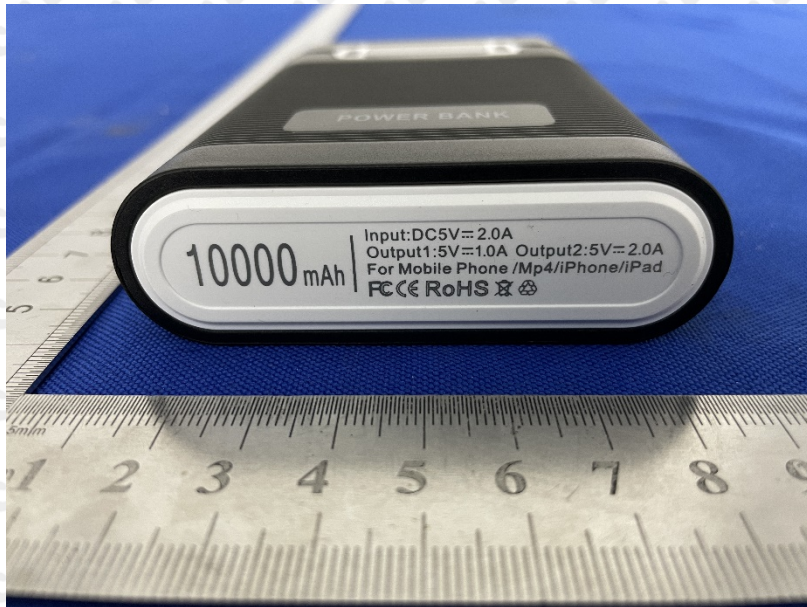
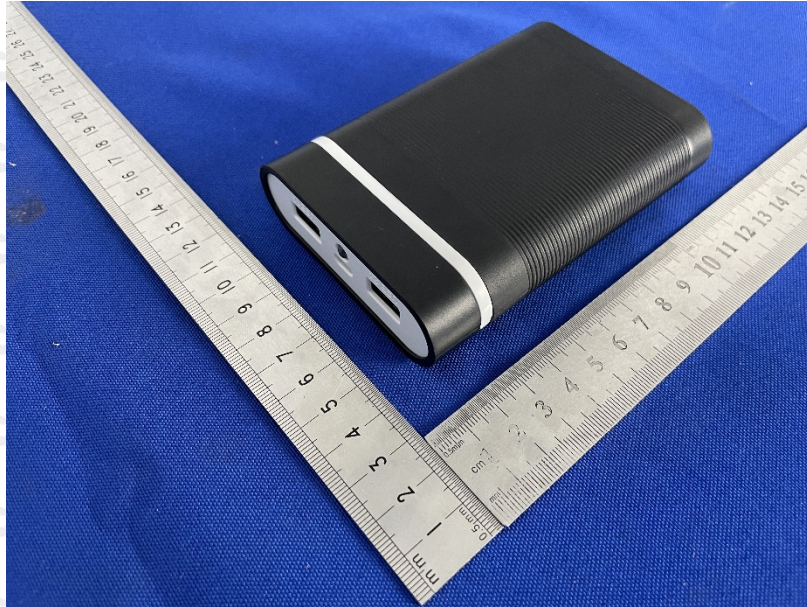

Photographs of EUT



Photographs of EUT

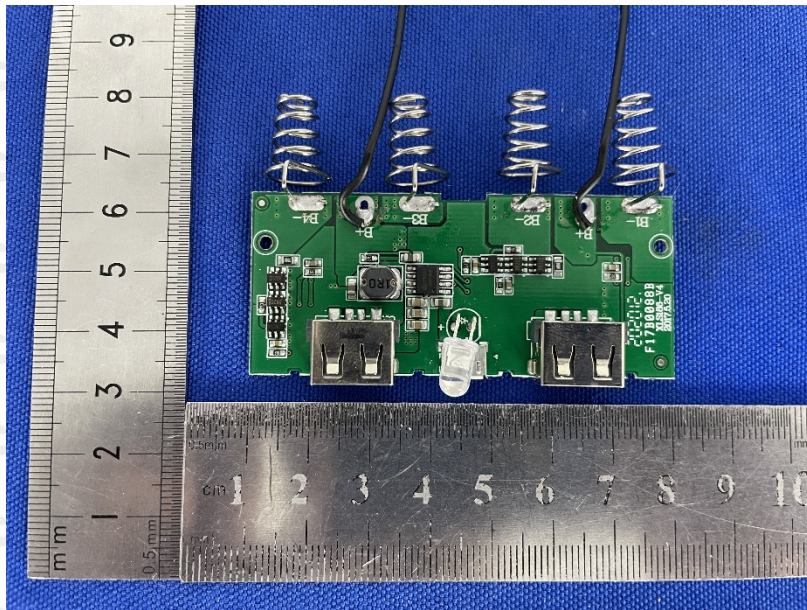
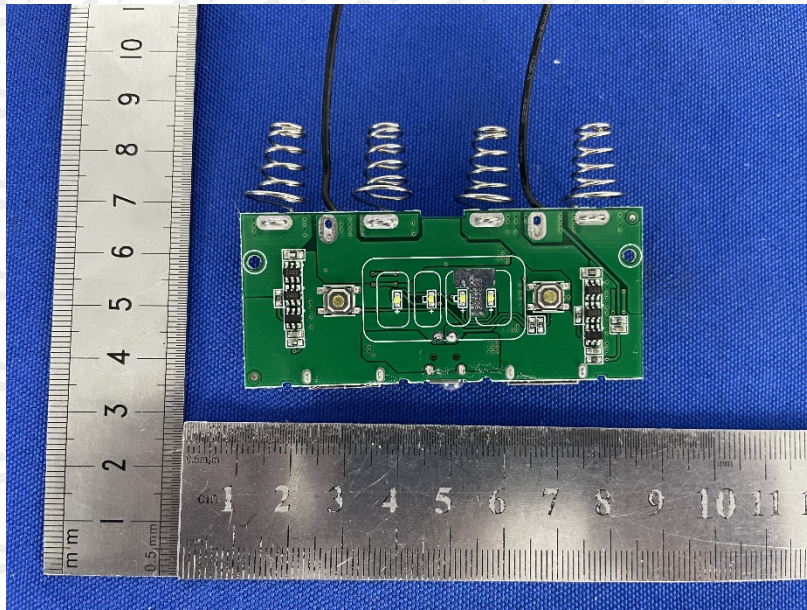

End of report