

GPS Vehicle Tracker

(GPS+GSM+SMS/GPRS)

User Manual



Preface

In order to get the correct installation and fast online activation ,Please read this manual carefully before using this product. Any changes about the appearance and color is subject to the real object.

1、Product package accessories

Power 7P line 1、GPS antenna 1、GSM antenna 1、Electrical relay 1、SOS button 1、Speaker 1 (Optional)、MIC 1 (Optional)

Accessories products refer to the real object

2、Product features

- Voltage range: 9-24VDC
- Built-in vibration sensor, Realization vehicle anti-theft intelligently
- ACC the ignition signal detection, vehicle status prompted;
- external SOS alarm button, used for emergency call for help;
- Built-in spare battery, realize illegal shear line alarm;
- External relay, cut off oil remotely (optional);
- external car horn, realize two-way talkback;;
- external microphone, to realize the remote speech monitoring function;

1、Red LED (GSM)

LED state	Meaning
Continuously in bright state	Search the GSM signal
Slow Flashing	Normal work
Continuously in dark state	Low power/Shut

2、Green LED (GPS)

LED state	Meaning
Slow Flashing	Normal work
Continuously in bright state	Search the GPS signal
Continuously in dark state	Low power/Shut

3、Appearance schematic diagram



the technical parameters:

- 1、 GSM bands: 900/1800MHz or 850/1900MHz
- 2、 GPRS: Class12, TCP/IP
- 3、 Voltage range: 9-24VDC
- 4、 Standby current: $\approx 0.2\text{mA}$
- 5、 consumption: 0.5w/h
- 6、 GPS positioning time: Cold start -38s(Open sky)
Warm start -32s
Hot start -2s(Open sky)
- 7、 GPS positioning precision: 10m(2D RM)
- 8、 Operating ambient temperature: $-20^{\circ}\text{C} - +70^{\circ}\text{C}$
- 9、 Work environment humidity: 20%-80%RH
- 10、 Dimensions: 80.0(L)*65.0(W)*25.0(H)mm
- 11、 Weight: 133g

4、 installation method

4.1 Before installation

- 4.1.1 1. Open the packing box to check whether the type of device is correct and whether the accessories are include. If there is something wrong or missing, please contact the distributor;
- 4.1.2 The selection of SIM card must follow the distributor's suggestion.
- 4.1.3 Install SIM card

Firstly, open the cover of the tracker and the cover on the slot for SIM card; secondly, insert the card into the slot; thirdly, fasten the slot; finally, recover the product and lock the shell tightly with four screws.

Tip:

- Don't insert the SIM card up-side-down. •*
- Make sure the SIM card with GPRS service.*
- Make sure the SIM card account has enough money*

Terminal connection diagram



Take card key: Press the popup SIM card slot

SIM: SIM

PHONE: Speaker

MIC: MIC

LED1: Power light

LED2: State light

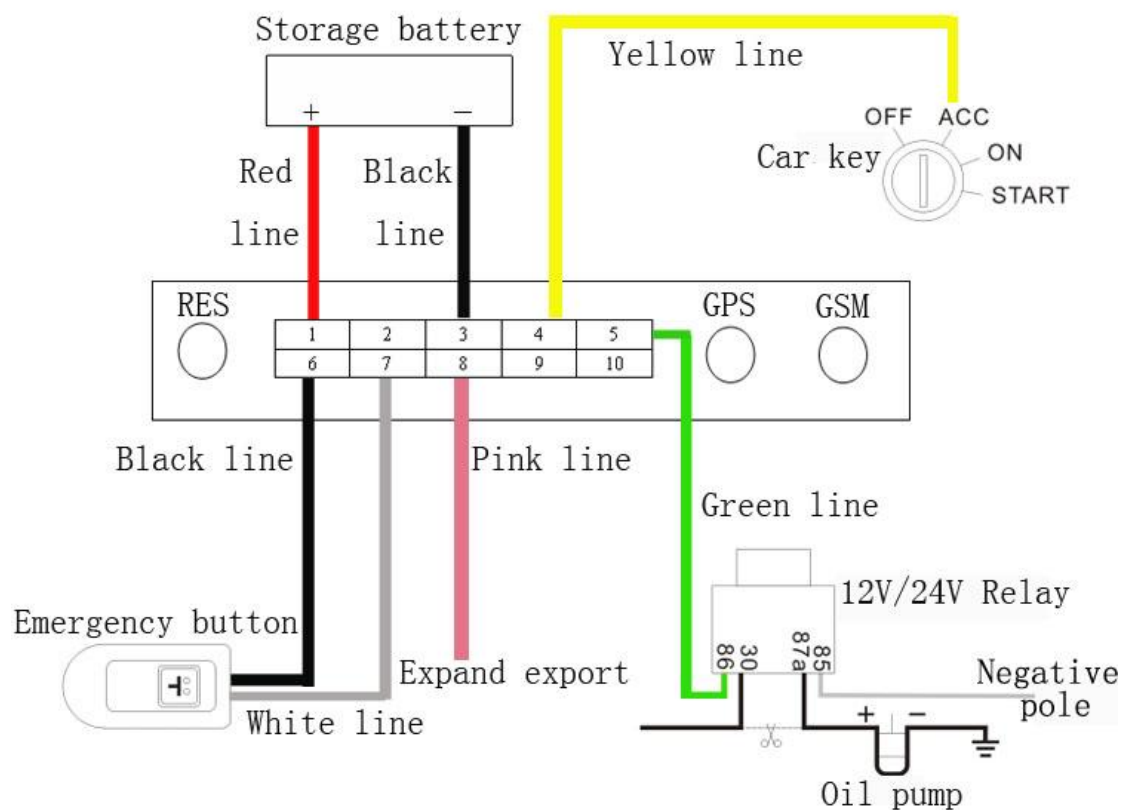

RES: Reset

GPS: GP S Antenna interface

GSM: GSM Antenna interface

2、8、9、10: Expand interface

4.2 Installation

This product is a high-tech electronic device , installation should be undertaken by professional companies or workers authorized by the distributor Please install the terminal according to the following order, please do not inverted it . During installation, there should be no power to the device. Terminal installation is recommended for hidden installation:

4.2.1 To avoid the thief's destruction, the tracker should be installed as covertly as possible. Suggestions are as follow: a, Hidden area under the decoration board below the front

windshield or back windshield; b, Shelter around the front instrument panel (non-metallic material face);

4.2.2 Avoid placing the device close to higher power electrical devices, such as reversing radar, anti-theft device or other vehicle communication equipment.

4.2.3 alarms and other vehicle-carried communication terminals.

4.2.4 You can fix the tracker with the cable tie, or glue it with wide strong sponge double-sided tapes.

4.2.5 Because the tracker has GSM and GPS antenna inside, please make sure the reception side of GPS is upward (facing the sky), and there is no metal shelter above the tracker.

Attention: If there is a metal insulation or a heating layer glued in the windshield, it will reduce the efficiency of

5、Equipment connect the matters needing attention

5.1 Power、ACC line、Oil cut-off electric control line (7pin)

5.1.1 This equipment is standard for power supply 9V~24VDC, please choose the original provide power supply cord, red line power positive, the black line for power negative; When installation, please choose to separate negative power grounding wires or by iron, don't another ground were answered.

5.1.2 ACC line (Yellow)

Please connect device' ACC line with vehicle's ACC switch, the tracker will determine vehicle status based on the state of ACC .starting or stationary, and decided to upload interval, start time: 15s, still time: 5min.

5.1.3 Relay wiring instructions

Oil pump cut-off relay connection method: Coil ends connection were thin white line (85) and fine yellow line (86), thin white line (85) car power negative, thin yellow line (86) joint terminal relay control line;

Accused of vehicles on the fuel cascading have oil pump, oil pump positive connecting wire cut, oil pump is extreme cascading in relay normally closed end (coarse green line 87 a), the other end joint relay public end (coarse green line 30).

5.1.4 SOS line (2pin)

External SOS Switch button , Used for emergency call for help;

5.1.5 Horn line (1pin)

External car horn, can realize two-way talkback.

5.1.6 MIC line (1pin)

External microphone, realize voice monitoring function;

5.2 please make sure to connect the power after the installation is complete;

5.3 concealed installation, power cable used original main power line, red line end string has a fuse box (2A fuse) which can play a short circuit overcurrent protection

6、Terminal operation use

1、boot/Shut down

6.1boot: Terminal boot (no spare battery version power on executive boot)。

Terminal state please see the second terminal state indicator.

6.2 Shut down: terminal power will be shut down。(No spare battery version pulled out power is turned off)

2、The terminal parameter setting

The following function parameters set instruction format, Initials letters are capital effectively . Instruction punctuation is English punctuation. Some commands have reply .

Send the query command , the terminal will return the corresponding content .

Language setting

Sent:LC (Chinese mode) or LE (English)

Set APN

Send APN:AA, XX, YY; AA is the operator APN, XX is the username, YY is the password;

Such as China Mobile: APN:cmnet,,

Such as Belgium : APN:web.pro.be, mobistar, mobistar

Mobile phone number binding

When Terminal work normally , please bind mobile phone number at first , as the receiving alarm message assignment number

Send *ZC#device password#main number#equipment SIM card number# (the initial password is 000000)

Such as: *ZC#000000#15888185569#12345678922#

Modify the login password

*MP#device password#new password(six digits)#

Such as: *MP#000000#987654#, 987654 is your new password, the initial password is 000000

SMS access equipment position

SMS access equipment position

Please send DW to the device to get the device location:

Such as: Cali - Valle del Cauca, Colombia

GOOGLE link address

Send GOOGLE to the device to get the device location link:

<http://maps.google.com/maps/?f=q&hl=en&q=3.43097,-76.53924&S=0&D=2012-5-2312:00:00&D=0>

Note: default as the international time, China time is the actual query time plus 8 hours

Such as: the actual query time is 12:00:00, China time is 20:00:00

3、Vibration alarm

When terminal startup fortification, and in the terminal fortification comes into force, the vehicle vibration happens many times, will trigger vibration alarm mechanism, terminal would immediately start vibration alarm. Terminal will be to set binding mobile phone number to send a vibration alarm message, and at the same time to the monitoring platform upload vibration alarm information.

Vibration alarm message example: "Vehicle vibration alarm, please immediate attention."

Tip:

To closed vibration alarm: hair message CF to equipment, success reply: close security success

To open vibration alarm: SF send text messages to equipment, success reply: open anti-theft monitoring

4、Oil electric control (optional)

When vehicle is stolen , you can send cut off oil command by monitoring platform , on the condition of ensure vehicles safe running , cut off stolen vehicle ' oil , then the vehicle will cannot continue to start ,

In order to guarantee the safety of vehicles, the terminal can executive oil electric operation only when GPS in the effective position, and the vehicle speed is less than 20 km / h conditions or when the vehicle is stationary . When the alarm is released, by monitoring platform Manual issued recovery oil electric command, the terminal performs recovery oil electric motor, the vehicle will can continue to run.

Disconnect the power source (oil) command : hair message DY000000 to equipment, and receive a success reply later

Open power source (oil) command : hair message TY000000 to equipment, and receive a success reply later

(the initial password is 000000)

5、SOS Alarm

When you meet the emergency need for help, can press the SOS key for 3 seconds, will trigger SOS emergency alarm. Terminal will be to set of SOS specific number send a SOS alarm message, and cycle call SOS binding number, in under the condition of no one answer, most only cycle call three times, terminal will also to monitoring platform upload SOS alarm information.

Mobile phone received alarm message example: SOS distress alarm, please immediate attention

6、Cut-off alarm

When terminal power supply was cut off, will trigger power alarm, will be to bind cell phone number to send a cut-off alarm message, and monitoring platform to upload cut-off alarm information.

SMS reply example: main power off electric alarm, please immediate attention

7、Monitoring(Optional)

Hair message JT to equipment, terminal ring in 15 s will automatically be in the monitoring state, when the caller can monitor vehicle internal environment voice. Non binding number calls, terminal will not enter the listening state.

8、talkback(Optional)

Binding cell phone number dialed equipment terminal, after connect the driver can be used a microphone dialogue.

Note: the vehicle must be on the horn or external speakers.

9、Battery low electric alarm

When the battery power alone, terminal internal battery power less than 10%, the terminal will be emitted by the low electric alarm message, and at the same time to monitoring platform upload low electric alarm information.

Low electric alarm message example: the attery power is low, please immediate attention.

7、location query platform

GPS services platform website:

If you in the platform have login information, you can directly landing platform service website. Otherwise, please contact your dealer for you to open the online landing account, provide login name and password.

On your computer browser address bar input service platform website, fill in the acquisition of the login account and password, then click landing into service platform. The function of the service platform operation please give your dealer for "service platform operation use guide".

8、Trouble shooting

1、please check the three lights of tracker, if you can' t check, please call

the terminal SIM card number, and judge the tracker status according to following instruction.

Please check the terminal installation:

- 1) main power supply connection is correct, be careful not to receive automobile internal control line, SIM is correct installation, please click reference installation instructions;
- 2) ACC point firewire if there is a pick, then insert the car keys to open ACC;
- 3) Check the LED light condition, normal when red light (GSM) slow flash, green light (GPS) slow flash;
- 4) check GPS is positioning, if not positioning please to outdoor open place for positioning;

2、terminal display in the background and status

First observation equipment three light is normal or not, in no condition to observe, to check the state of the card, steps are as follows:

- 1) call equipment SIM card number, see if you can hear the phone on voice;
- 2) vehicle is in the basement no cover GSM network signal.
- 3) observation got disconnected area, is individual got disconnected or all got disconnected, in order to determine whether the network for operators,
- 4) whether the SIM card of credit;
- 5) GPRS business is not open;

3、if the terminal GPS function has been activated, but long time not positioning, please check the terminal installation position in compliance with requirements:

- 1) terminal in equipment installation, should make GPS antenna face toward the sky.
- 2) terminal installation position must be above is not the electromagnetic wave absorption material (such as metal) keep out of place, special attention should be paid to terminal position above the vehicle glass don't post explosion-proof insulation membrane (membrane composition is of high metal components, can absorb high frequency electromagnetic wave), otherwise the GPS signal will receive a lot of attenuation cause positioning accuracy down, serious when can make even terminal hard to locate.

4、When GPS signal receiving environment is bad (peripheral have tall buildings keep out GPS signal), please drive to the sky is open place to locate, general first positioning time need 1-2 minutes.

5、When GSM signal receiving anomaly, please check the terminal SIM card is correct installation; Or to place may not cover GSM signal (such as in the basement), please drive to have GSM signal coverage of place to use.

6、Specific number receive cell phone power alarm message, to determine whether illegal shear line, otherwise please check the power cord on the fuse is fuse, if the fuse please contact your dealer replacement with specifications of fuse, check and eliminate terminal internal fault rear can again power on work.