

智能高清可视猫眼

用户操作手册

User manual

快速入门指南

感谢您购买我公司的智能可视门铃，为了帮助您正确操作，请在使用前仔细阅读本说明书。

产品特点：

超高亮度 TFT LCD 显示屏
自带存储功能
135度广角镜头
24小时安全监控
夜视功能
易于安装和操作

产品参数

- 1.传感器：30万像素 CMOS 有源数字图像传感器
- 2.变焦：3 倍数码变焦
- 3.门铃：门铃功能，4 种铃声可供选择
- 4.TF 卡插槽：支持最大 32GB
- 5.夜视：2 颗带夜视功能的红外 LED 灯,LED 在背光下会自动开启
- 6.门孔直径：14-60mm
- 7.门板厚度：35-110mm
- 8.产品尺寸：95*85*17mm

产品图：

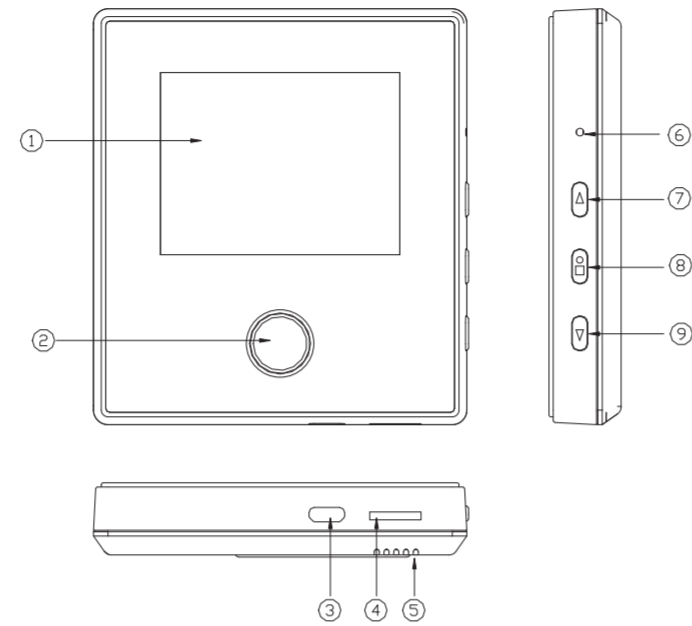

1 LED显示器	7 上翻按钮
2 确定按键	8 菜单按钮
3 USB充电	9 下翻按钮
4 TF卡插槽	
5 喇叭	
6 复位开关	

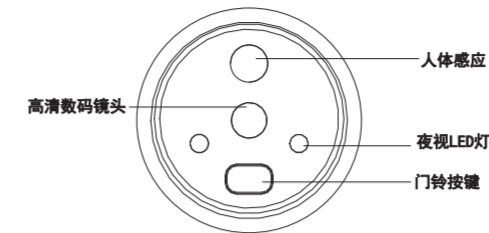

菜单设置：

工作状态，按“M”键，进入菜单设置

1. 日期：在此菜单中可设置时间与日期。
2. 自动关机：在此菜单中可设置自动关机时间（关闭，10秒，20秒，30秒）。
3. 语言：有简体中文，繁体中文，English。（语言可自定义）。
4. 频率：有 50HZ 和 60HZ，两种选择。
5. 格式化：此菜单可删除所有数据。
6. 模式：可选择拍照或者录像记录。
7. 预览：此菜单可以预览所有拍照或者录像记录。
8. 免打扰：此菜单如选择“打开”则按门铃没有铃声。
9. 夜视：此菜单如选择“关闭”则没有夜视功能。
10. 移动侦测：人体感应设置。
11. 铃声大小：高，中，低三种选择。
12. 铃声设置：有 4 种铃声选择。
13. LCD 开关：此功能如选择“关闭”则感应到人显示屏不会打开。
14. 退出：退出主菜单设置。

设备操作

1. 门铃：当访客按门铃按钮，室内机设备将响起“叮咚”，屏幕会自动打开，室内用户可看到门外访客。
2. 拍照方式 1：当访客按门铃按钮，照片和日期将会保存在本机内。
3. 拍照方式 2：当室内机显示访客时，用户可在室内机短按“确定”按键，则可拍照。
4. 录像：在菜单模式中，设置录像功能，当有访客则自动录像。
5. 回放：用户可在主菜单“预览”，“照片记录”中查看照片或录像。

安装指南：

步骤 1：将外机防盗胶撕开，选择适合的螺丝拧在导杆上，将导杆穿入门孔。
步骤 2：把室内金属支架防盗胶撕开，排线导入支架方孔，用导杆上螺丝和是金属支架连接并锁紧螺丝，请保持金属支架挂钩向上。
步骤 3：将 FPBC 接头插入室内机设备上，箭头向上。
步骤 4：室内机固定在金属支架上。
步骤 5：重复检查 FPBC 接头是否与设备连接；在门外按门铃按钮进行测试。

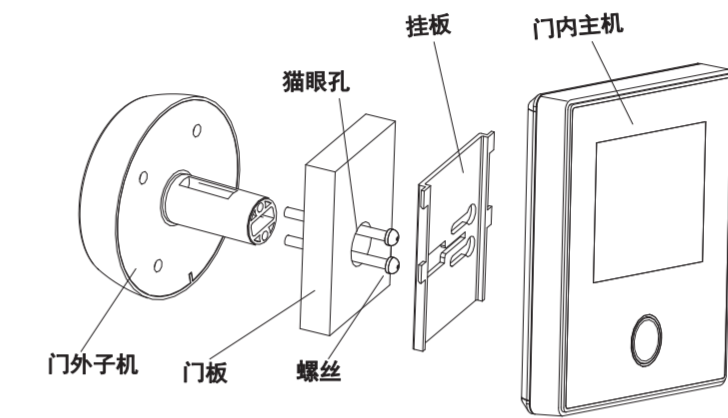

包装内容：

1 室外机 2 室内主机 3 螺丝（6个） 4 充电线 5 用户手册 6 包装

注意：3 种螺丝，根据门的厚度选择螺丝，短的螺丝用于 3.5-6cm 厚度的门。长的螺丝用于 7-11cm 厚度的门（超过 110mm 门螺丝可以定制）。

产品保修条款：

本公司的产品将严格遵守国家颁发的相关法律，遵照《微型计算机商品修理更换退货责任规定》的具体条款和相关规定，执行公司的售后服务。

1. 服务期限：

公司承诺新产品的良好品质，产品自出售之日起7日内正常使用中出现故障，消费者可以选择免费退货，换货或者修理，消费者购机后正常使用一年内出现故障可免费保修。对于不满足免费更换或免费保修服务的消费者，我公司依然提供技术服务，当需要维修更换零件时收取材料费。

2. 购买时间以经销商开出的购机发票或收据日期为准。

3. 有下列情况之一者不能享受三包服务。

- a. 一切人为因素损坏，包括非正常工作环境下使用，不按说明书使用或未依据说明书指示的环境下使用导致的故障的损坏等等
- b. 未经本公司同意，用户私自拆机，自行修复，改装
- c. 购机后因不良运输造成的损坏
- d. 因其他不可抵抗力（如水灾，雷击，大地震，异常电压）造成的损坏
- e. 正常用旧，磨损和破裂，生锈或污染
- f. 不属于本公司的产品（如假货）
- g. 不能出示有效的购机凭证

4. 包换，保修程序：

客户购机后使用出现故障，应带收据或者发票到经销商处联系保修服务事宜，如果问题没有得到妥善解决，请致电本公司客户服务部

Smart HD Visual Doorbell

用户操作手册

User manual

Quick guide:

Thank you for purchasing digital door viewer from our company. In order to help you operate it correctly, please read this instruction carefully before using.

Product feature:

Ultra bright TFT LCD display
With storage function
135deg. Wide-angle lens
24hours security surveillance
Night vision
Easy install and operate

Technical specification:

1. Sensor: CMOS digital sensor
2. Zoom: 3X digital zoom
3. Doorbell: 4 kinds ringtone for choosing
4. TF card slot: Support up to 32GB
5. Infrared: 2pcs IR LED for night vision, LED will turn on automatically in poor light.
6. Door hole dia.:14-60mm
7. Door thickness:35-110mm
8. Product size:95*85*17mm

Product image:

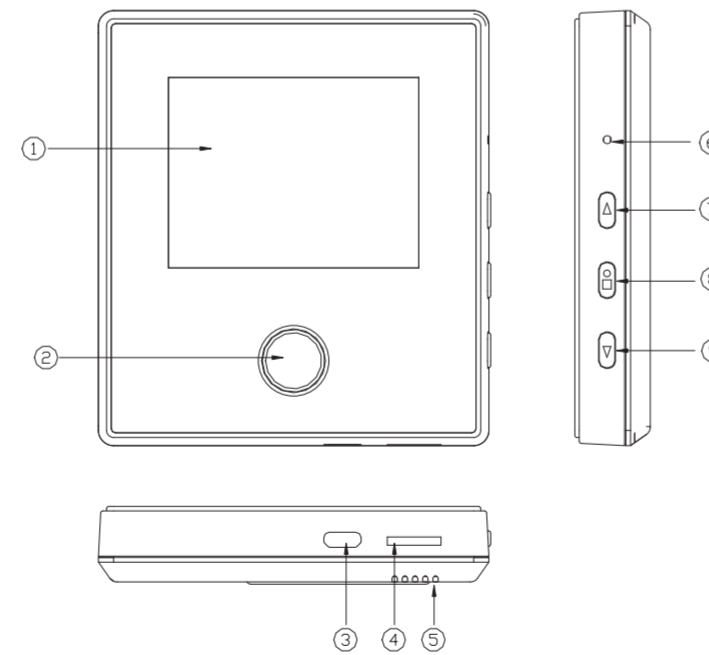

1 LED display	6 Reset button
2 Power button	7 UP button
3 USB charge port	8 Menu button
4 TF card slot	9 Down button
5 Speaker	

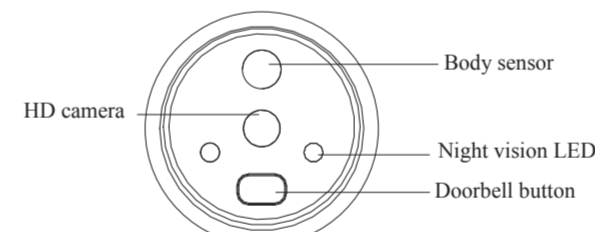

Menu setting:

Press "M" button enter into main interface.

- 1.Date / time:set current time.
- 2.Auto power off:10s, 20s, 30s for choosing
- 3.Language: Simplified Chinese, Traditional Chinese, English(support customize).
- 4.Light frequency: 50HZ and 60HZ for choosing
- 5.Format: Empty the SD card
- 6.Mode selection: Photo mode and record mode for choosing.
- 7.Preview: Check the photos and video
- 8.Silent mode: No ringtone when select ON
- 9.Infrared: No night vision when select OFF
- 10.Volume: High, Medium, Low for choosing.
- 11.Ringtone: 4 kinds for choosing
- 12.LCD switch: turn on the display, when detected visitor, it will open automatically and take photo or record. if turn off, it won't open automatically but also can take photo or record.

Device operation:

- 1.Doorbell: When visitors press doorbell button, indoor device will ring "Ding dong" and LCD display will turn on automatically, also the visitor will show on the display.
- 2.Camera mode 1: when visitor press doorbell button, the device will take photo and save it with current date.
- 3.Camera mode 2: when visitor show on the display, the user can short press "power" button to take photo.
- 4.Recording: Set in the menu. it will record automatically.
- 5.Playback: User can check the recorded photos and videos in menu,

Install guide:

Step 1: Tear off the device film, doorbell install on the outside.
Step 2: Fix the metal bracket on indoor with screw, Please keep the metal bracket hook upward.
Step 3: Put FPBC plug insert the indoor device.
Step 4: Fix the indoor device on the metal bracket.
Step 5: Double checks the FPBC connects with the device. Finally, Press outside doorbell to test the function

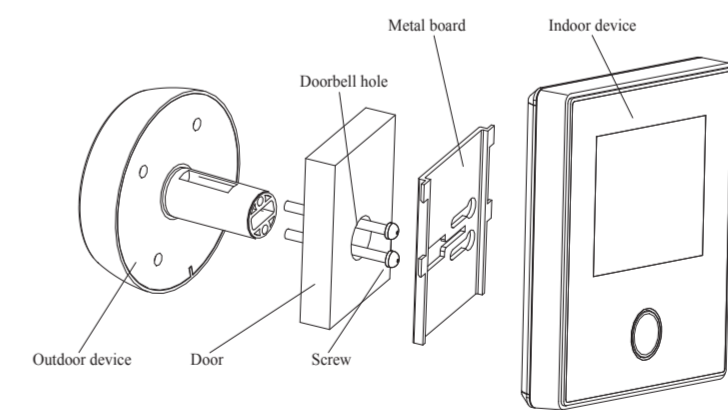

Package content:

1 Outdoor device 2 Indoor device 3 Screws (6pcs) 4 Charging cable
5 User manual 6 Packaging

Tips: 3 kinds screw, Use which screw based on the thickness of the door. Short screw for 3.5-6cm door. Long screw for 7-10cm door. (Door over 110mm,can customized the screw).

Product guarantee clause

The product in our company will be strictly compliance the relevant laws award by our country. Comply with Specific terms and related provisions of "Commodity of Micro Computer replacement and return responsibility rules" to stipulate the company

After-sales service.

1. Service deadline:

Our company promise excellent product quality, The customer can be returns & replacement free of charge or free repair if the product is broken within 7 days from the date of sale. The product can be repaired free of charge in normal operation within one year from the date of sale. For the customer who not meet the service of free charge of replacement or repair, our company also provide technical service. It will be charged if need repair or replace accessories.

2. Purchase date is based on the date of purchase invoice or receipt made out by distributor.

3. The service of three guarantees doesn't cover following

All the artificial damage, include Abnormal Operation, not in accordance with manual operating caused product damage.

- a. Unauthorized by our company, user disassemble the parts, self-restore, self-modification.
- b. Any manage caused by harmful transportation.
- c. Any damage caused by force majeure (such as flood, lightning stroke, earthquake, abnormal voltage)
- d. Well-worn, abrasion, broken, rust or dip dyeing
- e. The product is not belong to our company(such as fakes)
- f. Can not provide valid purchase evidence.

4. Guarantee replacement, warranty procedure: The customer should take the invoice or other valid purchase evidence to the distributor after-sale service department to deal with warranty issues if the device can not work.