

PURE SINE WAVE INVERTER

300W-6000W Multi-function LCD display

DC TO AC



User Manual

2021-V1.0

CONTENTS

1. Preface	01
2. Matters needing attention	01
3. Product features	02
4. Product application	02
5. Panel description	03-05
6. Liquid crystal display	06
7. Protection function	06
8. Liquid crystal display	08
9. Remote control instructions	08
10. Display instructions	09-10
11. Product parameters	11-12
12. Installation requirements	13
13. Wiring requirements	13
14. Common problems and solutions ...	14
15. After-sales service	15

Please read the instruction manual carefully before use.
This manual refers to the graphic reference, whichever is the real thing.

PREFACE

Dear user:

First of all, thank you for choosing our pure sine wave inverter. All products of our company have undergone strict production control, quality control and accurate testing and proof, so that all the requirements specified in the specifications can be met after delivery. Users can rest assured to buy and use!

PRECAUTIONS

The installation and commissioning of this equipment shall be carried out by professional electrical maintenance personnel who are familiar with the structure and operation of the device. Failure to follow this precaution could result in bodily harm.

Do not connect this equipment to a consumer utility line box, such as a home line.

Keep the inverter away from water, and avoid dropping water on the machine or getting it up. Do not insert or pull the plug with wet hands. Keep the inverter in a cool environment, suitable temperature should be $-20^{\circ}\text{C} \sim 40^{\circ}\text{C}$, avoid direct sunlight and hot vents.

Keep the inverter away from flammable materials or where flammable gases accumulate.

After prolonged use, the inverter will heat up, so avoid getting close to heat sensitive substances.

Make sure the vents are smooth and well cooled.

Do not open the machine due to high voltage danger.

Use a suitable type of wire to avoid blowing the wire due to excessive inverter current.

Make sure the inverter is connected to the correct battery, otherwise the fuse of the inverter will be blown. Turn off the switch when the machine is not in use. Please turn off the switch before cleaning and clean it with a dry cloth. Do not use a damp cloth or detergent.

FEATURES

The inverter power supply adopts SPWM technology controlled by MCU micro-processing, pure sine wave output, and the waveform is pure.

The unique dynamic current loop control technology ensures reliable operation of the inverter.

Load adaptability, including inductive load, capacitive load, resistive load, mixed load.

Heavy load capacity and impact resistance.

It has perfect protection functions such as input overvoltage, undervoltage, overload, overheat, and output short circuit.

The sine wave inverter adopts LCD liquid crystal display mode, and the state is clear at a glance.

Stable performance, safe and reliable, long service life.

APPLICATIONS

Power Tools: Circular saws, electric drills, grinding machines, grinders, bumpers, weeders and trimmers, air compressors

Home entertainment electronic devices: TV, video cassette recorders, video game consoles, audio, musical instruments, satellite equipment

Industrial equipment: cloud server, face recognition server, intelligent manufacturing robot, emergency system

Household appliances: vacuum cleaners, fans, fluorescent and incandescent lamps, razors, sewing machines

Office equipment: computers, printers, surveillance, fax machines, scanners

Kitchen appliances: coffee machine, blender, ice mark, toaster

PANEL DESCRIPTION

POWER:300W-500W

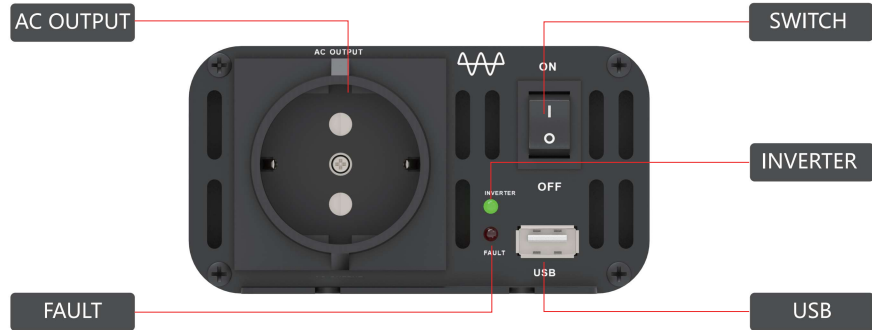

PANEL DESCRIPTION

POWER:600W-2500W

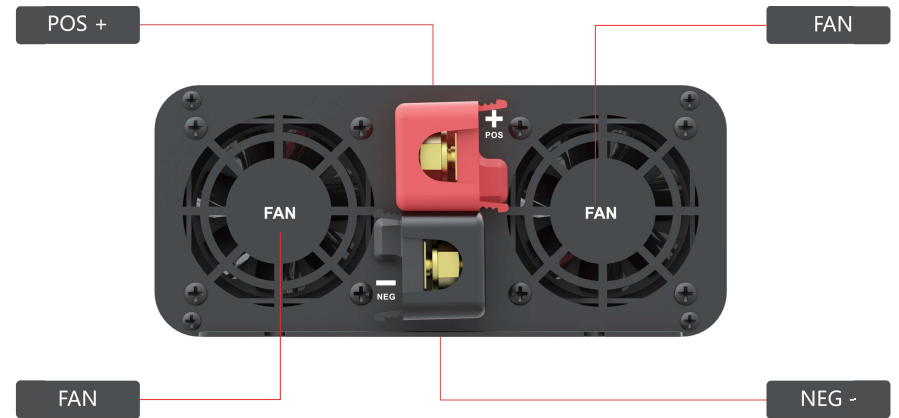
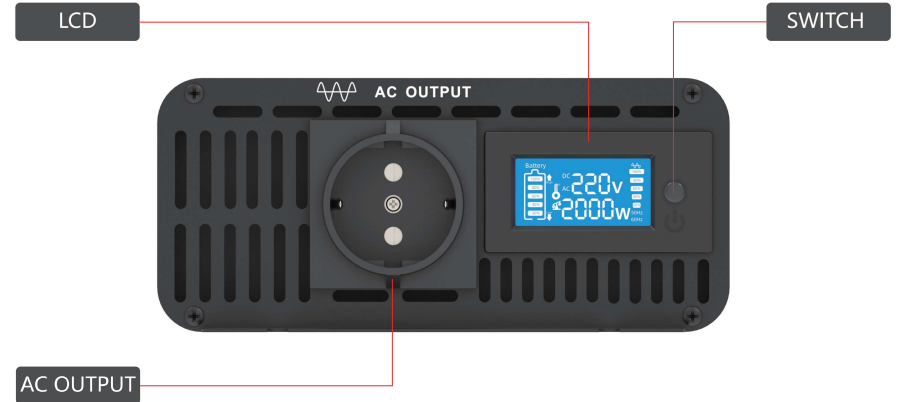

PANEL DESCRIPTION

POWER:3000W-6000W

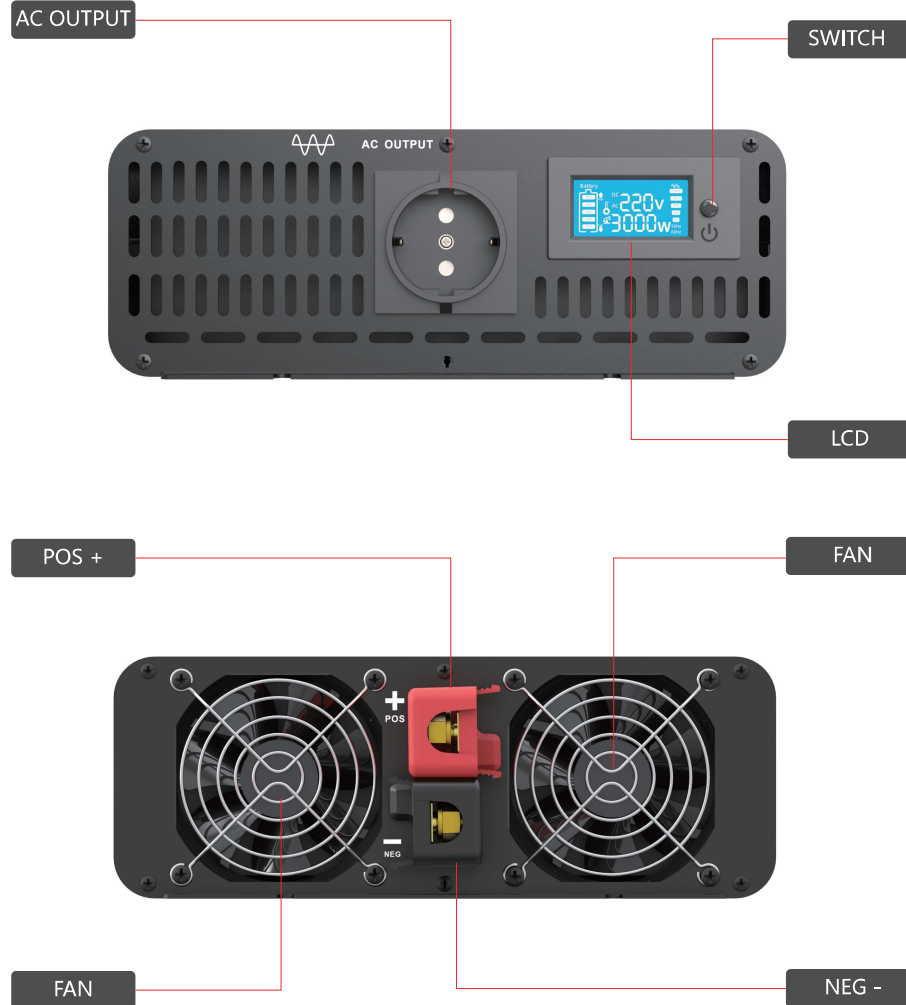

Display (1)

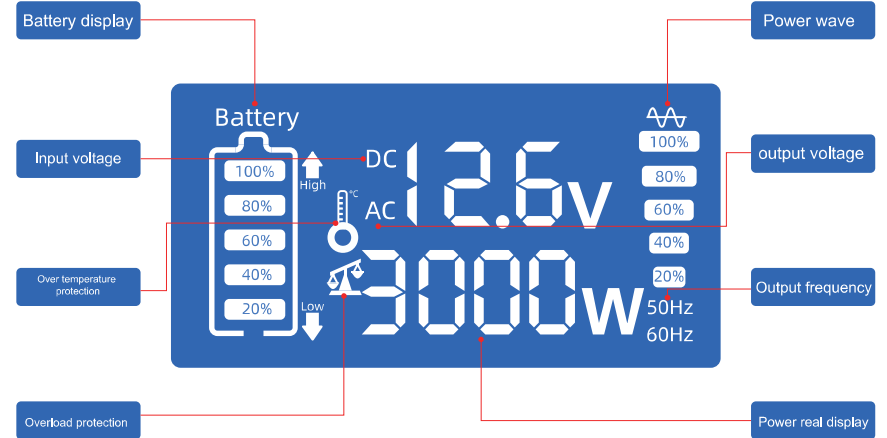

Protective function

- (1) Low-voltage alarm: The buzzer sounds 2 audible with 1 Hz gap.
- (2) Low voltage protection: The buzzer continuously sounds 3time alarm, with1 Hz gaps
- (3) Low-voltage recovery: the low-voltage rise automatically restores the output, and the buzzer sounds 3times alarm is cancelled.
- (4) Overvoltage protection: The buzzer sounds 4 times, with 1 Hz gap.
- (5) Overvoltage recovery: The voltage is reduced automatically to restore the output, and the buzzer sounds 4times alarm is cancelled.
- (6) thermal protection: $80^{\circ} \pm 5^{\circ}$, when overheat protection buzzer sounds 5times alarm, with1Hz gap
- (7) Overload protection: 10S automatic shutdown output for overload protection, 5S automatic recovery, automatic locking for three consecutive times
- (8) Short circuit protection: Output short circuit protection 1S shutdown lock.
- (9) The input is reversed: the fuse is blown.

Display (2)

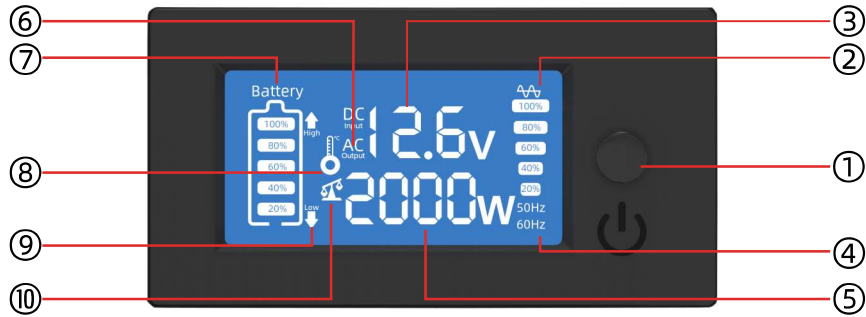

①switch

1. Press for 1 second to turn on

2. Press for 3 seconds to shut down

3. Press the energy-saving mode twice, and press once to restore

4. Power on and press for 3 seconds to pair the wireless remote control

②Load ratio

③Battery voltage

④Output frequency

⑤Output power

⑥Output voltage

⑦Battery capacity

⑧Overheat protection

⑨ Low voltage protection

⑩Overload protection

Remote

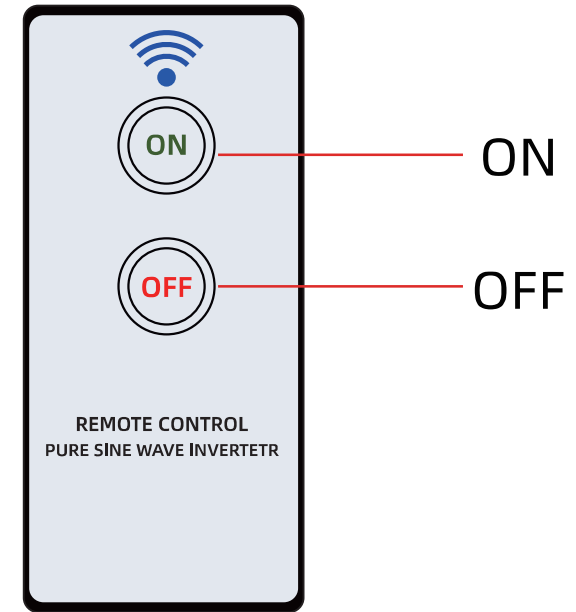

Remote control

Instructions

The remote control needs to be paired with the inverter before use; long press to reverse Change the power on button for 3 seconds, then press the remote power on button again to complete the setting. remote control

The control range of the device is less than or equal ≤ 10 meters.

Remote protocol:RF

Remote control is optional

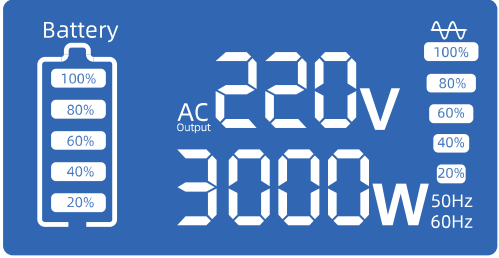
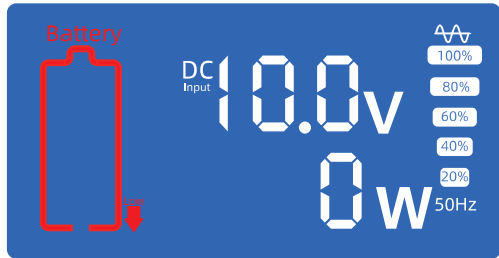
	<p style="text-align: center; background-color: #4CAF50; color: white; padding: 5px;">Show description</p> <ol style="list-style-type: none"> 1. Battery capacity 2. Power display 3. Input voltage 4. Output power 5. Load ratio 6. Output frequency 50/60Hz
	<p style="text-align: center; background-color: #4CAF50; color: white; padding: 5px;">Show description</p> <ol style="list-style-type: none"> 1. Battery capacity 2. Power display 3. Output voltage 110V or 220V 4. Output power 5. Load ratio 6. Output frequency 50/60Hz
	<p style="text-align: center; background-color: #FFC107; color: white; padding: 5px;">Low voltage protection</p> <ol style="list-style-type: none"> 1. Measured battery voltage 2. The battery indicator flashes 3. The output voltage is 0 volts 4. Output power 0 watts 5. Load ratio 0% 6. Buzzer 3×Beeep

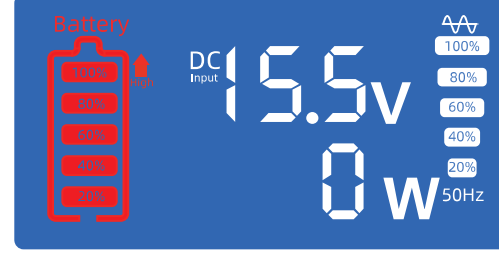
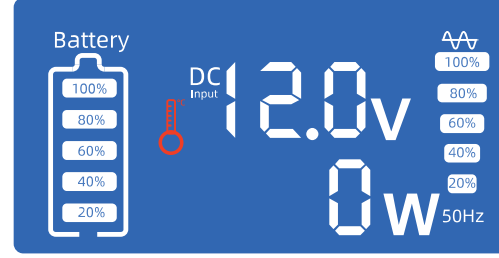
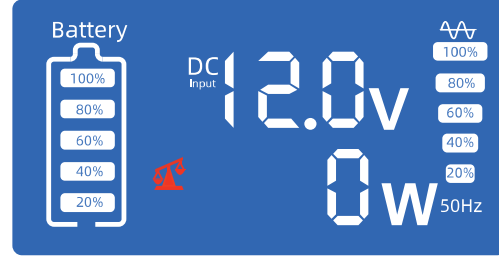
	<p style="text-align: center; background-color: #FFC107; color: white; padding: 5px;">Overvoltage protection</p> <ol style="list-style-type: none"> 1. Measured battery voltage 2. The battery indicator flashes 3. The output voltage is 0 volts 4. Output power 0 watts 5. Load ratio 0% 6. Buzzer 4×Beeeeep
	<p style="text-align: center; background-color: #D32F2F; color: white; padding: 5px;">Overheating protection</p> <ol style="list-style-type: none"> 1. The battery voltage is normal 2. The battery display is normal 3. The output voltage is 0 volts 4. Output power 0 watts 5. Load ratio 0% 6. Buzzer 5×Beeeeeep
	<p style="text-align: center; background-color: #D32F2F; color: white; padding: 5px;">Overload protection</p> <ol style="list-style-type: none"> 1. The battery voltage is normal 2. The battery display is normal 3. The output voltage is 0 volts 4. Output power 0 watts 5. Load ratio 0% 6. Buzzer Beeeeep.....

Technical specifications

Model	300W	600W	1000W	1500W	2000W
Output Power	300W	600W	1000W	1500W	2000W
Display method	LED	LCD			
Input voltage	12V/24V/48V/60V/72Vdc				
Input range	12Vdc(10-15),24Vdc(20-30),48Vdc(40-60),60Vdc(50-75),72Vdc(60-90)				
Low voltage protection	12V(15.0V±0.3),24V(30.0V±0.3),48V(60.0V±0.3),60V(75.0V±0.3),72V(90.0V±0.3)				
Overvoltage protection	12V(15.0V±0.3),24V(30.0V±0.3),48V(60.0V±0.3),60V(75.0V±0.3),72V(90.0V±0.3)				
Recovery voltage	12V(13.2V±0.3),24V(25.5V±0.3),48V(51.0V±0.3),60V(65.0V±0.3),72V(78.0V±0.3)				
No-load current	0.35A	0.50A	0.60A	0.60A	0.70A
Overload protection	≤130%				
output voltage	110Vac±10% or 220Vac±10%				
Output frequency	50Hz±1Hz or 60Hz±1Hz				
Output waveform	Pure sine wave				
Overheating protection	80°±5°				
Waveform THD	≤3%THD				
Conversion efficiency	90%				
cooling method	Fan cooling				
Dimensions	183*110*60mm	228*173*76mm	300*173*76mm	360*173*76mm	
product weight	1.0kg	2.0kg	3.0kg	3.5kg	4.0kg

Technical specifications

Model	2500W	3000W	4000W	5000W	6000W
Output Power	2500W	3000W	4000W	5000W	6000W
Display method	LCD				
Input voltage	12V/24V/48V/60V/72Vdc				
Input range	12Vdc(10-15),24Vdc(20-30),48Vdc(40-60),60Vdc(50-75),72Vdc(60-90)				
Low voltage protection	12V(15.0V±0.3),24V(30.0V±0.3),48V(60.0V±0.3),60V(75.0V±0.3),72V(90.0V±0.3)				
Overvoltage protection	12V(15.0V±0.3),24V(30.0V±0.3),48V(60.0V±0.3),60V(75.0V±0.3),72V(90.0V±0.3)				
Recovery voltage	12V(13.2V±0.3),24V(25.5V±0.3),48V(51.0V±0.3),60V(65.0V±0.3),72V(78.0V±0.3)				
No-load current	0.35A	0.50A	0.60A	0.60A	0.70A
Overload protection	≤130%				
output voltage	110Vac±10% or 220Vac±10%				
Output frequency	50Hz±1Hz or 60Hz±1Hz				
Output waveform	Pure sine wave				
Overheating protection	80°±5°				
Waveform THD	≤3%THD				
Conversion efficiency	90%				
cooling method	Fan cooling				
Dimensions	360*173*76mm	400*242*88mm		420*242*88mm	
product weight	4.0kg	7.5kg	8.0kg	9.0kg	10.0kg

USE ENVIRONMENT

Install the inverter according to local power requirements.

The installation location must be dry, clean and well ventilated.

Working temperature : -20°C to 40°C

Storage temperature : -10 to 40°C

Relative humidity : 0%-90%, no condensation

Cooling: forced ventilation

WIRING REQUIREMENTS

1 meter long battery line configuration requirements.

POWER	DC INPUT	WIRE DIAMETER
600W	12V	10AWG
600W	24/48V	12AWG
1000W	12V	7AWG
1000W	24/48V	10AWG
2000W	12V	4AWG
2000W	24/48V	7AWG
3000W	12V	2AWG
3000W	24/48V	4AWG
4000W	12V	1AWG
4000W	24/48V	4AWG
5000W	12V	2AWG*2
5000W	24/48V	4AWG

- Subject to outside interference
- The inverter may be affected by some strong electromagnetic waves in the use, such as nearby motors, power inverters, strong magnetic fields, etc.
Inverter indicator is not light
 1. The battery and inverter are not connected and reconnected.
 2. The pole of the battery is reversed and the fuse is blown. Replace the fuse.
- Low output voltage
 1. Overload, the load current exceeds the nominal current, and some of the load is turned off to restart.
 2. The input voltage is too low. Make sure the input voltage is within the nominal voltage range.
- Low voltage alarm
 1. The battery is out of power and needs to be charged.
 2. The battery voltage is too low or the contact is poor, recharge, check the battery terminals or clean the terminals with a dry cloth.
- Inverter has no output
 1. The battery voltage is too low, recharge or replace the battery.
 2. The load current is too high, and some of the load is turned off to restart the inverter.
 3. Inverter over temperature protection. Allow the inverter to cool for a while and place it in a well ventilated area.
 4. The inverter failed to start and restarted.
 5. The terminal is reversed, the fuse is blown, and the fuse is replaced.

FORM ON VOLTS / HZ AND PLUG STYLE FOR WORLDWIDE COUNTRY(AREA)

Country	Volts/Hz	Plug style
NORTH AMERICA		
Canada	120V/60Hz	A&B
U.S.A	120V/60Hz	A&B
CENTRAL AMERICA		
Anguilla	110V/60Hz	C
Antigua	230V/60Hz	A&B
Bahamas	120V/60Hz	A&B
Barbados	115V/50Hz	A&B
Belize	110/220V/60Hz	B&G
Bermuda	120V/60Hz	A&B
Costa Rica	120V/60Hz	A&B
Cuba	110/220V/60Hz	A&B C&L
Dominica	230V/50Hz	D&G
Dominican	110V/60Hz	A
Grenada	230V/50Hz	G
Guatemala	120V/60Hz	A,B,G,&I
Haiti	110V/60Hz	A&B
Honduras	110V/60Hz	A&B
Jamaica	110V/50Hz	A&B
Mexico	127V/60Hz	A
Netherlands	230V/50Hz	C&F
Nicaragua	230V/50Hz	I
Panama	110V/60Hz	A&B
Puerto Rico	120V/60Hz	A&B
Virgin Islands	110V/60Hz	A&B
SOUTH AMERICA		
Argentina	220V/50Hz	C&I
Brazil	110/220V/60Hz	A&B&C
Chile	220V/50Hz	C&L
Colombia	110V/60Hz	A&B
Ecuador	120/127V/60Hz	A&B
Guyana	240V/60Hz	A&D&G
Paraguay	220V/50Hz	C
Peru	220V/60Hz	A&B&C
Surinam	127V/60Hz	C&F
Uruguay	220V/50Hz	CFI&L
Venezuela	120V/60Hz	
AUSTRALIA OCEANIA		
Australia	230V/50Hz	I
Fiji Island	40V/50Hz	I
Guam	110V/60Hz	A&B
New Caledonia	20V/60Hz	F
New Zealand	230V/50Hz	I
Tahiti	110V/220V/60Hz	A&B&E
Tonga	240V/50Hz	I
EUROPE		
Austria	230V/50Hz	C,F
Azores	220V/50Hz	B,C,F
Belgium	230V/50Hz	E
Bulgaria	230V/50Hz	C&F
Channel Islands	240V/50Hz	C&G
Czechoslovakia	230V/50Hz	E
Denmark	230V/50Hz	C&K
Finland	230V/50Hz	C&F
France	230V/50Hz	C&E
Germany	230V/50Hz	C&F
Greece	220V/50Hz	A,D,E,F
Greenland	220V/50Hz	C&K
Hungary	230V/50Hz	C&F
Iceland	220V/50Hz	C&F
Isle of Mun	230V/50Hz	H&C
Italy	230V/50Hz	F&L
Luxembourg	220V/50Hz	C&F
Malta	240V/50Hz	G
Monaco	127V/220V/50Hz	C,D,E,F
Netherlands	230V/50Hz	C&F
Norway	230V/50Hz	C&F
Poland	230V/50Hz	C&F
Portugal	220V/50Hz	C&F

Country	Volts/Hz	Plug style
Romania	230V/50Hz	C&F
Spain	230V/50Hz	C&F
Sweden	230V/50Hz	C&F
Switzerland	230V/50Hz	J
England	230V/50Hz	G
Yugoslavia	220V/50Hz	C&F
AFRICA		
Gambia	230V/50Hz	G
Ghana	230V/50Hz	D&G
Guinea	220V/50Hz	C,F&K
Kenya	240V/50Hz	G
Lesotho	220V/50Hz	M
Libya	127V/60Hz	D
Mali	220V/50Hz	C&E
Morocco	127V/220V/50Hz	C&E
Rwanda	230V/50Hz	C&J
Senegal	230V/50Hz	C,D,E&K
Seychelles	240V/50Hz	G
Somalia	220V/50Hz	C
South Africa	220V/230V/50Hz	M
Sudan	230V/50Hz	C&D
Tanzania	230V/50Hz	D&G
Togo	220V/50Hz	C
Uganda	240V/50Hz	G
Zimbabwe	220V/50Hz	D&G
Algeria	230V/50Hz	C&F
Angola	220V/50Hz	C
Benin	220V/50Hz	E
Burundi	220V/50Hz	C&E
Cameroun	220V/50Hz	C&E
Chad	220V/50Hz	D,E,F
Congo	230V/60Hz	C&E
Djibouti	220V/60Hz	C&E
Egypt	220V/50Hz	C
Ethiopia	220V/50Hz	D,J,L
Gabon	220V/50Hz	C
AFRICA		
Afghanistan	220V/50Hz	C&FD
Iran	230V/50Hz	D
Iraq	230V/50Hz	C,D&G
Jordan	230V/50Hz	D,F,G,J
Kuwait	240V/50Hz	C&G
Lebanon	230V/50Hz	A,B,C,D,G
Oman	240V/50Hz	C&G
Pakistan	230V/50Hz	C,D
Qatar	240V/50Hz	D&G
Saudi Arabia	127/220V/50Hz	A,B,F,G
Syria	220V/50Hz	C,E,L
Turkey	230V/50Hz	C,F
United Arab Emirates	220V/50Hz	C,D,G
ASIA		
Bangal	220V/50Hz	A,C,D,G,K
Brunei	240V/60Hz	G
Cambodia	230V/50Hz	A,C
China	220V/50Hz	A,I,G
Hong Kong	220V/50Hz	D,G
India	240V/50Hz	C,D,G
Indonesia	127/230V/50Hz	C,F,G
Japan	100V/60/50Hz	A,B
Korea(South)	220V/50Hz	C,F
Laos	230V/50Hz	A,B,C,E,F
Macao	220V/50Hz	D,G
Malaysia	240V/50Hz	G
Nepal	230V/50Hz	C,D
Philippines	220V/60Hz	A,B,C
Singapore	230V/50Hz	G
Sri Lanke	230V/50Hz	D
Taiwan	110V/160Hz	A,B
Thailand	220V/50Hz	A,C
Russian	220V/50Hz	C
Vietnam	220V/50Hz	A,C,G

All the data are for reference only, please refer to actual data of country/Area

Meal case, good to assemble the following output sockets:

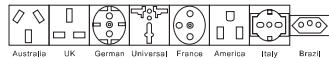

Australia UK German Universal France America Italy Brazil

Plug style

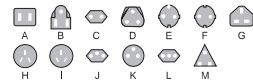

Certificate of conformity

Product name: see nameplate
 Product model: see nameplate
 Factory number: see bar code
 Inspection date: see barcode

PASS
QC 01

