



FCC TEST REPORT

for

Battery Charger

FPT-250

Prepared for: DongGuan Foxsur Electronic Equipment Co., Ltd.
Hengjiangxia Industrial Zone, ChangPin Tower, DongGuan City,
GuangDong Province, China

Prepared by: Shenzhen EZT Testing Technology Co.,Ltd
3F, Building B, Weicheng Industrial Park, No.16 Nanhuan Road, Matian
Street, Guangming District, Shenzhen City, Guangdong Province, China.

Tel: +86-0755-33150178

Fax: +86-0755-23218109

Report Number: EZT20240116113FR

Date of Test: Jan.08,2024-Jan.16,2024

Date of Issue: Jan.16,2024

Tested By Mark Dan.
Mark Dan

Approved By Steven
Steven

The results detailed in this test report relate only to the specific sample(s) tested. It is the Application's responsibility to ensure that all production units are manufactured with equivalent EMC characteristics. This report is not to be reproduced except in full, without written approval from EZT Testing Technology.



Table of contents

1.0 General Information	3
1.1 Client Information	3
1.2 General Description of E.U.T.	3
1.3 Test Facility:	4
2.0 List of Measurement Equipment	5
2.1 Conducted Emission Test.....	5
2.2 Radiated Emission Test.....	5
3.0 Technical Details	6
3.1 Investigations Requested	6
3.2 Test Standards	6
3.3 Measurement Uncertainty.....	6
4.0 Power Line Conducted Emission Test	7
4.1 Schematics of the test	7
4.2 Test Method and test Procedure	7
4.3 EUT Operating Condition.....	8
4.4 Test Equipment	8
4.5 Power line conducted Emission Limit	8
4.6 Photo documentation of the test set-up.....	8
4.7 Test specification:	8
4.8 Test result.....	8
5.0 Radiated Emission Test	11
5.1 Test Method and test Procedure:.....	11
5.2 EUT Operating Condition.....	12
5.3 Radiated Emission Limit	12
5.4 Photo documentation of the test set-up.....	12
5.5 Test Equipment:	12
5.6 Test specification:	12
5.7 Test result.....	12
6.0 FCC Label	15
7.0 Photos of the EUT	16



1.0 General Information

1.1 Client Information

Application:	DongGuan Foxsur Electronic Equipment Co., Ltd.
Address of Application:	Hengjiangxia Industrial Zone, ChangPin Tower, DongGuan City, Guangdong Province, China
Manufacturer:	DongGuan Foxsur Electronic Equipment Co., Ltd.
Address of Manufacturer:	Hengjiangxia Industrial Zone, ChangPin Tower, DongGuan City, Guangdong Province, China

1.2 General Description of E.U.T.

Product Name:	Battery Charger
Model:	FPT-250
Additional Model:	N/A
Trade Mark:	FOXSUR
Power Supply:	Input:100-240V~50/60Hz 350W Output:12V $\overset{\sim}{\sim\sim}$ 25A; 24V $\overset{\sim}{\sim\sim}$ 15A
Model Difference:	N/A



Report No.: EZT20240116113FR

1.3 Test Facility:

Name of Test Lab:	Shenzhen EZT Testing Technology Co., LTD
Address of Test Lab:	3F, Building B, Weicheng Industrial Park, No.16 Nanhuan Road, Matian Street, Guangming District, Shenzhen City, Guangdong Province, China.
Telephone:	+86-0755-33150178
Fax:	+86-0755-23218109



Report No.: EZT20240116113FR

2.0 List of Measurement Equipment					
2.1 Conducted Emission Test					
Name	Model No.	Serial No.	Manufacturer	Date of Cal.	Due Date
EMI Test Receiver	ESCS30	1102.4500.30	RS	July 22, 2023	July 21, 2024
LISN	LS16C	10010947251	AFJ	July 22, 2023	July 21, 2024
2.2 Radiated Emission Test					
Name	Model No.	Serial No.	Manufacturer	Date of Cal.	Due Date
EMI Test Receiver	ESVD	1026.5506.10	RS	July 22, 2023	July 21, 2024
Spectrum Analyzer	FSEM	1079.8500.30	RS	July 22, 2023	July 21, 2024
Coaxial Switch	MP59B	M70585	ANRITSU	N/A	N/A
Amplifier	8447D	2727A05017	HP	July 22, 2023	July 21, 2024
Bilog Antenna	VULB9163	9163/340	Schwarebeck	July 22, 2023	July 21, 2024



3.0 Technical Details

3.1 Investigations Requested

Perform Electromagnetic Interference [EMI] tests for FCC Requirement.

3.2 Test Standards

FCC Part 15 Subpart B:2017

3.3 Measurement Uncertainty (95% confidence levels, k=2)

No.	Item	MU
1.	Temperature	$\pm 0.1^{\circ}\text{C}$
2.	Humidity	$\pm 1.0\%$
3.	Spurious emissions, conducted	$\pm 3.70\text{dB}$
4.	All emissions, radiated	$\pm 4.50\text{dB}$

4.0 Power Line Conducted Emission Test

4.1 Schematics of the test

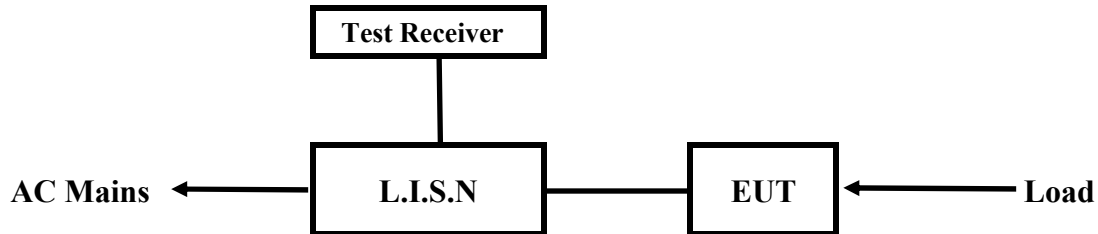

EUT: Equipment Under Test

4.2 Test Method and test Procedure

The EUT was tested according to ANSI C63.4-2014. The Frequency spectrum From 0.15MHz to 30MHz was investigated. The LISN used was 50ohm/50uH as specified by section 5.1 of ANSI C63.4 –2014.

Test Voltage: 120V~, 60Hz

Block diagram of Test setup

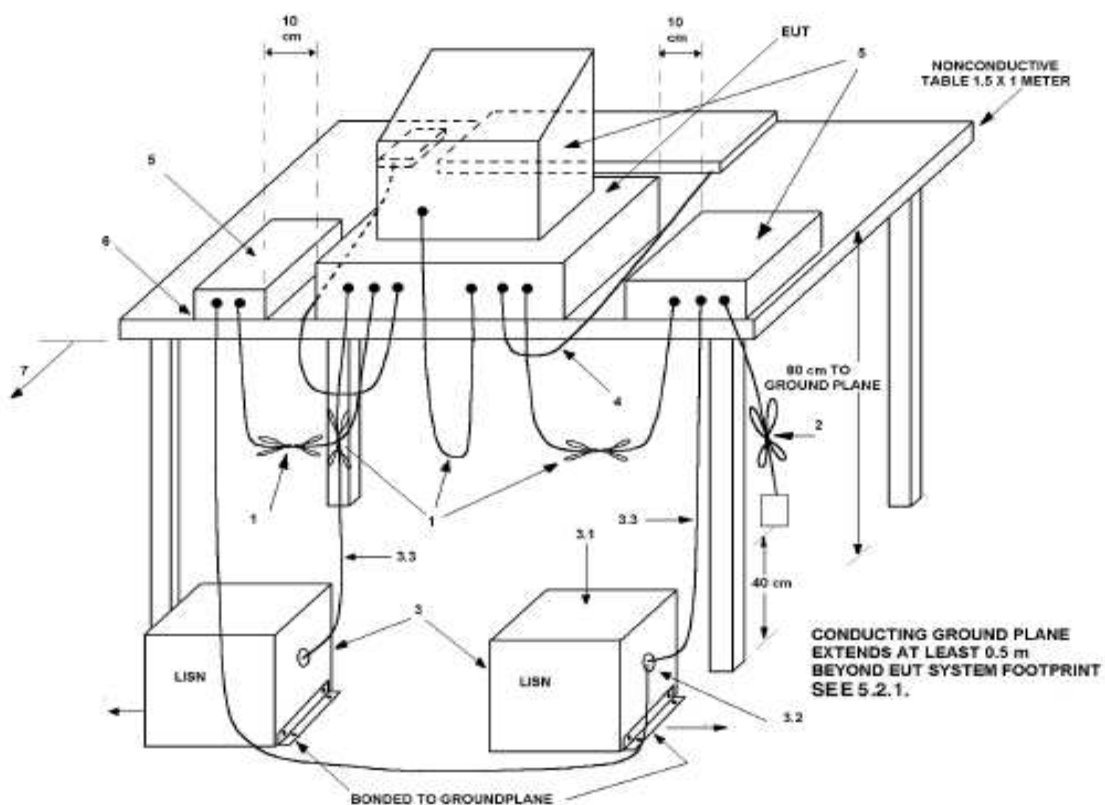



4.3 EUT Operating Condition

Operating condition is according to ANSI C63.4 -2014

- 1) Setup the EUT and simulators as shown on the following
- 2) Enable AF signal and confirm EUT active to normal condition

4.4 Test Equipment

Please refer to the Section 2

4.5 Power line conducted Emission Limit

Frequency(MHz)	Class A Limits (dBμV)		Class B Limits (dBμV)	
	Quasi-peak Level	Average Level	Quasi-peak Level	Average Level
0.15 ~ 0.50	79.0	66.0	66.0~56.0*	56.0~46.0*
0.50 ~ 5.00	73.0	60.0	56.0	46.0
5.00 ~ 30.00	73.0	60.0	60.0	50.0

- Notes:
- 1. *Decreasing linearly with logarithm of frequency.
 - 2. The tighter limit shall apply at the transition frequencies

4.6 Photo documentation of the test set-up

Please refer to the Section 7

4.7 Test specification:

Environmental conditions: Temperature: 26° C Humidity: 51% Atmospheric pressure: 103kPa

Frequency range: 0.15 MHz – 30 MHz

4.8 Test result

The requirements are fulfilled

Remarks: According to the FCC part 15 Subpart B:2017



A Conducted Emission on Line Terminal of the power line (150kHz to 30MHz)

Site LAB	Phase: L1	Temperature: 24.9
Limit: FCC Part 15 CLASS B QP	Power: AC 120V/60Hz	Humidity: 47 %
EUT:		
M/N:		
Mode:		
Note:		
Engineer Signature:		

Conducted Emission Measurement

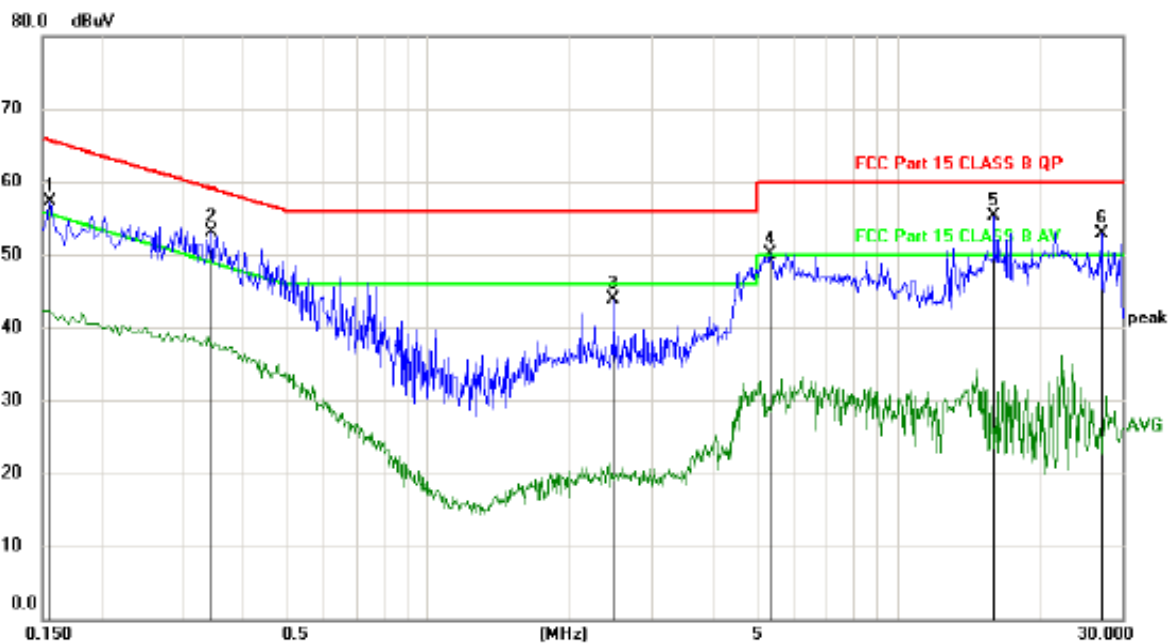

No.	Mk.	Freq. MHz	Reading Level dBuV	Correct Factor dB	Measurement dBuV	Limit dBuV	Margin dB	Detector	Comment
1		0.1559	47.70	9.66	57.36	65.68	-8.32	peak	
2		0.3450	43.41	9.70	53.11	59.08	-5.97	peak	
3		2.4749	33.93	9.93	43.86	56.00	-12.14	peak	
4		5.3460	39.96	10.17	50.13	60.00	-9.87	peak	
5	*	16.0049	44.93	10.45	55.38	60.00	-4.62	peak	
6		27.1110	42.09	10.86	52.95	60.00	-7.05	peak	



B Conducted Emission on Neutral Terminal of the power line (150kHz to 30MHz)

Site LAB	Phase: N	Temperature: 24.9
Limit: FCC Part 15 CLASS B QP	Power: AC 120V/60Hz	Humidity: 47 %
EUT:		
M/N:		
Mode:		
Note:		
Engineer Signature:		

Conducted Emission Measurement

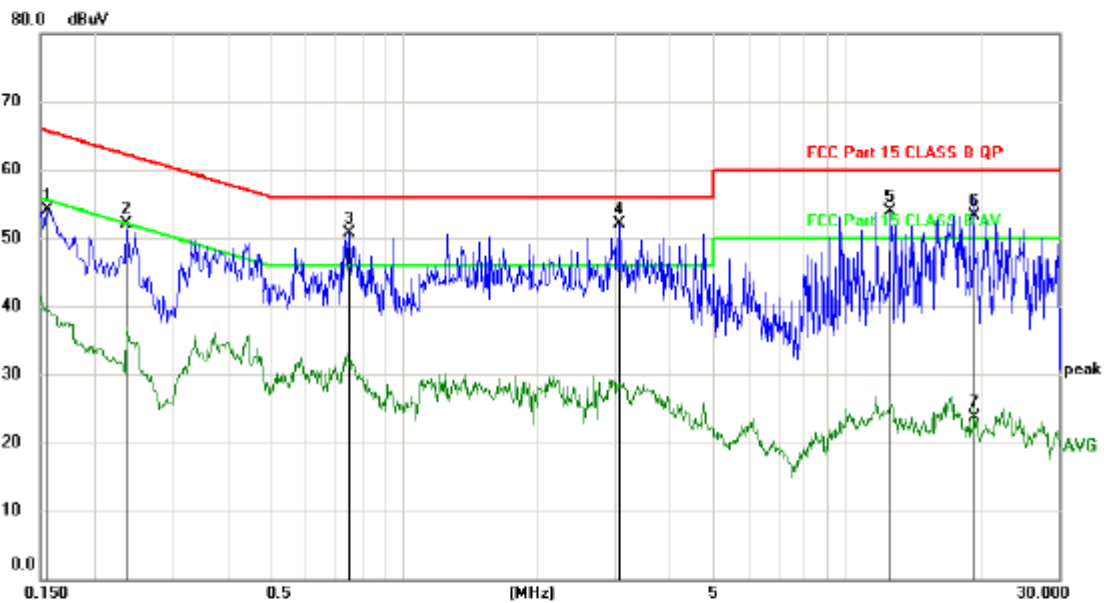

No.	Mk.	Freq. MHz	Reading Level dBuV	Correct Factor dB	Measure- ment dBuV	Limit dBuV	Margin dB	Detector	Comment
1		0.1559	44.52	9.66	54.18	65.68	-11.50	peak	
2		0.2341	42.49	9.68	52.17	62.30	-10.13	peak	
3		0.7500	40.89	9.74	50.63	56.00	-5.37	peak	
4	*	3.0660	42.12	10.00	52.12	56.00	-3.88	peak	
5		12.4530	43.54	10.36	53.90	60.00	-6.10	peak	
6		19.2810	42.78	10.45	53.23	60.00	-6.77	QP	
7		19.2810	13.21	10.45	23.66	50.00	-26.34	AVG	

5.0 Radiated Emission Test

5.1 Test Method and test Procedure:

- 1) The EUT was tested according to ANSI C63.4 –2014
- 2) The EUT, peripherals were put on the turntable which table size is 1m x 1.5 m, table high 0.8 m. All set up is according to ANSI C63.4-2014
- 3) The antenna high is varied from 1 m to 4 m high to find the maximum emission for each frequency.
- 4) The antenna polarization: Vertical polarization and Horizontal polarization.

Block diagram of Test setup

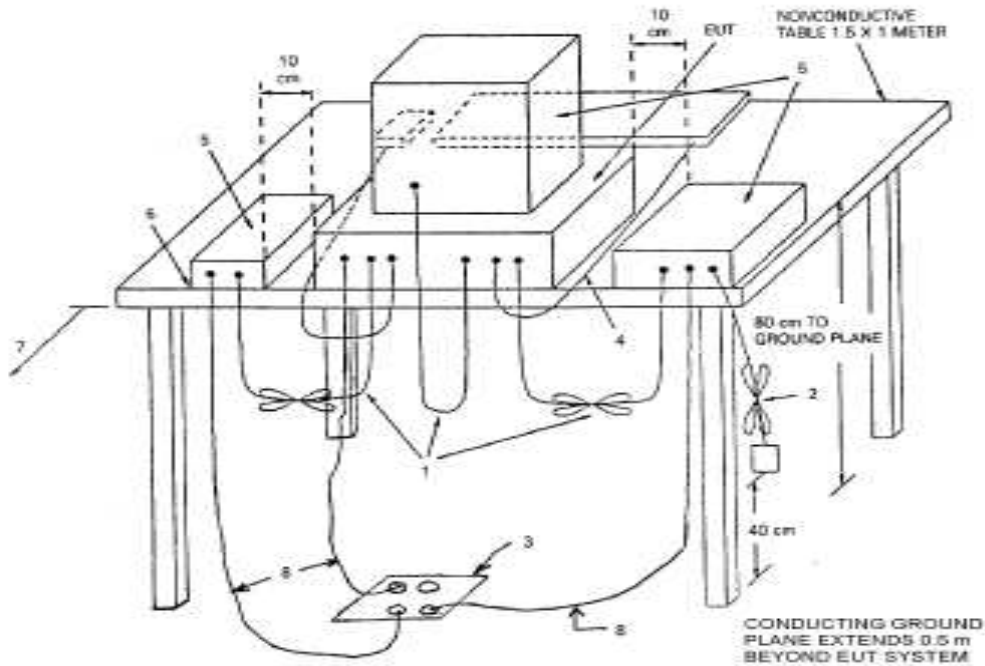
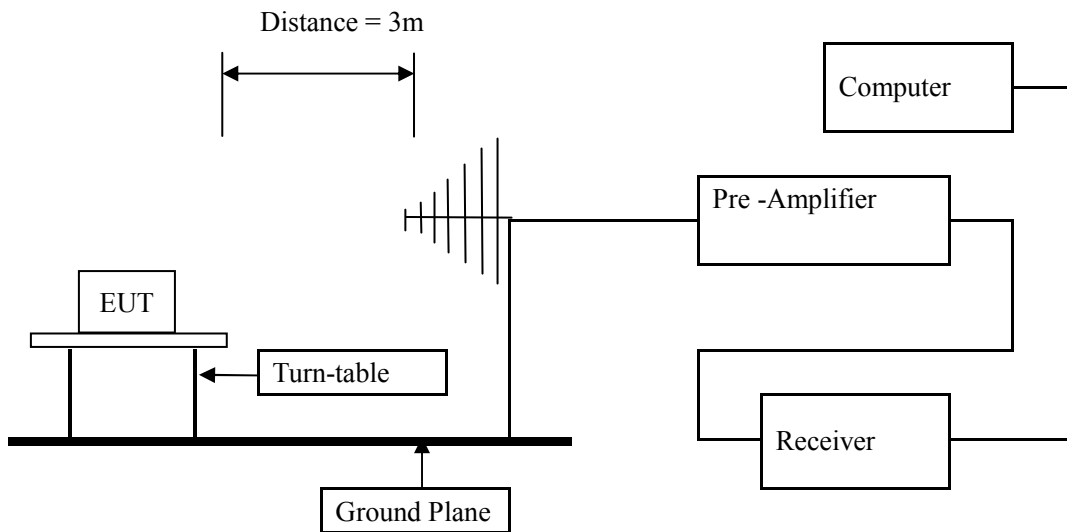



5.2 EUT Operating Condition

Operating condition is according to ANSI C63.4 -2014

5.3 Radiated Emission Limit

All emission from a digital device, including any network of conductors and apparatus connected thereto, shall not exceed the level of field strength specified below:

Frequency Range (MHz)	Distance (m)	Field strength (dB μ V/m)
30-88	3	40.0
88-216	3	43.5
216-960	3	46.0
Above 960	3	54.0

- Note:
- 1) The frequency spectrum from 30MHz to 8GHz was investigated. All reading from 30MHz to 1GHz are quasi-peak values with a resolution bandwidth of 120KHz. For measurement above 1GHz, peak values with RBW=VBW=1MHz and PK detector. AV value with RBW=1MHz, VBW=10Hz and PK.
 - 2) Measurements were made at 3 meters.
 - 3) If measurement is not made at 3m distance, then F.S Limitation at 3m distance is adjusted by using the formula $Ld1 = Ld2 * (d2/d1)$

5.4 Photo documentation of the test set-up

Please refer to the Section 7

5.5 Test Equipment:

Please refer to the Section 2

5.6 Test specification:

Environmental conditions: Temperature 26° C Humidity: 55% Atmospheric pressure: 103kPa

5.7 Test result

The requirements are fulfilled

Remarks: According to the FCC part 15 Subpart B:2017



A. Radiated Emission In Horizontal (30MHz----1000MHz)

Site LAB 966-2 Chamber	Polarization: <i>Horizontal</i>	Temperature: 23.8
Limit: FCC Part 15 Class B Radiation	Power:	Humidity: 56 %
EUT:	Distance: 3m	
M/N:		
Mode:FULL LOAD		
Note:		
Engineer Signature:		

Radiated Emission Measurement

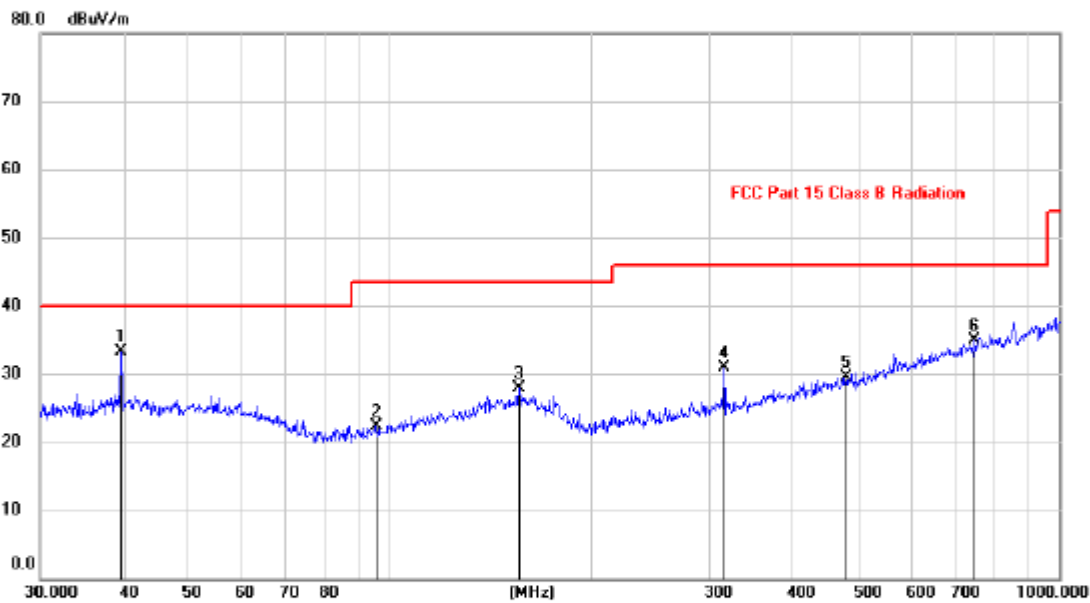

No.	Mk.	Freq.	Reading Level	Correct Factor	Measurement	Limit	Margin	Antenna Height	Table Degree	
		MHz	dBuV	dB	dBuV/m	dBuV/m	dB	cm	degree	Comment
1	*	39.5757	19.13	14.22	33.35	40.00	-6.65	peak		
2		95.4270	12.11	10.25	22.36	43.50	-21.14	peak		
3		155.9101	13.38	14.57	27.95	43.50	-15.55	peak		
4		316.5890	17.20	13.79	30.99	46.00	-15.01	peak		
5		478.8456	12.47	17.06	29.53	46.00	-16.47	peak		
6		750.1083	13.69	21.31	35.00	46.00	-11.00	peak		



B. Radiated Emission In Vertical (30MHz----1000MHz)

Site LAB 966-2 Chamber	Polarization: <i>Vertical</i>	Temperature: 23.8
Limit: FCC Part 15 Class B Radiation	Power:	Humidity: 56 %
EUT:	Distance: 3m	
M/N:		
Mode: FULL LOAD		
Note:		
Engineer Signature:		

Radiated Emission Measurement

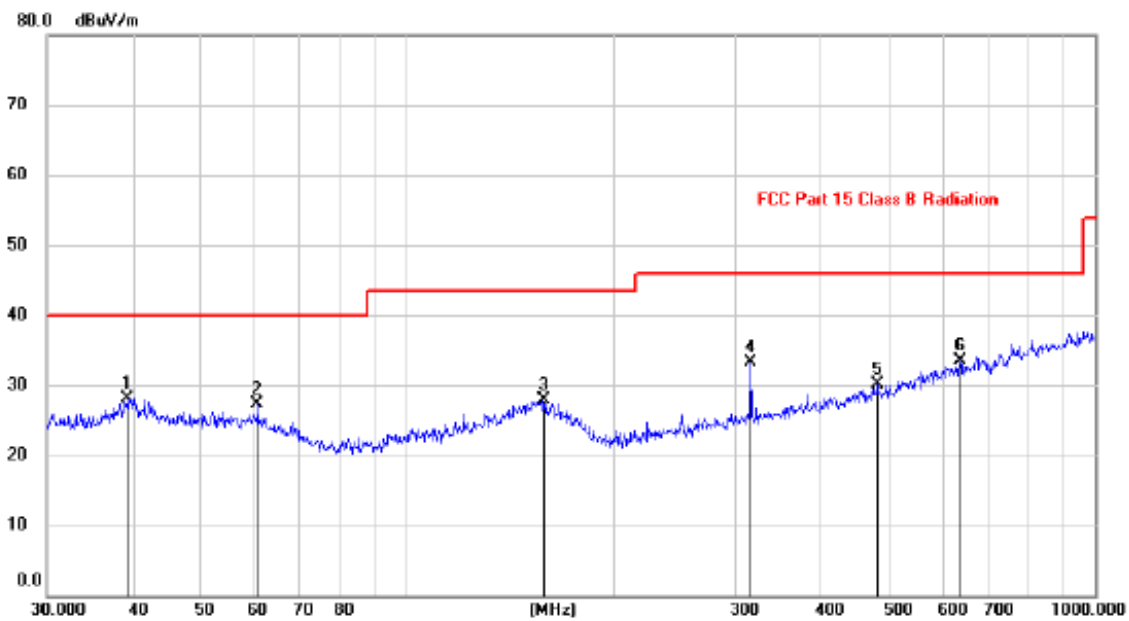

No.	Mk.	Freq. MHz	Reading Level dBuV	Correct Factor dB	Measure- ment dBuV/m	Limit dBuV/m	Margin dB	Antenna Height cm	Table Degree	Comment
1	*	39.2991	13.99	14.21	28.20	40.00	-11.80	peak		
2		60.9176	14.71	12.57	27.28	40.00	-12.72	peak		
3		157.5588	13.38	14.57	27.95	43.50	-15.55	peak		
4		316.5890	19.52	13.79	33.31	46.00	-12.69	peak		
5		482.2156	13.00	17.14	30.14	46.00	-15.86	peak		
6		636.1340	13.47	19.95	33.42	46.00	-12.58	peak		



6.0 FCC Label

This device complies with part 15 of the FCC rules. Operation is subject to the following two conditions (1) this device may not cause harmful interference, and (2) this device must accept any interference received, including interference that may cause undesired operation.

The label must not be a stick-on paper label. The label on these products must be permanently affixed to the product and readily visible at the time of purchase and must last the expected lifetime of the equipment not be readily detachable.



Mark Location: On the product body

7.0 Photo of EUT

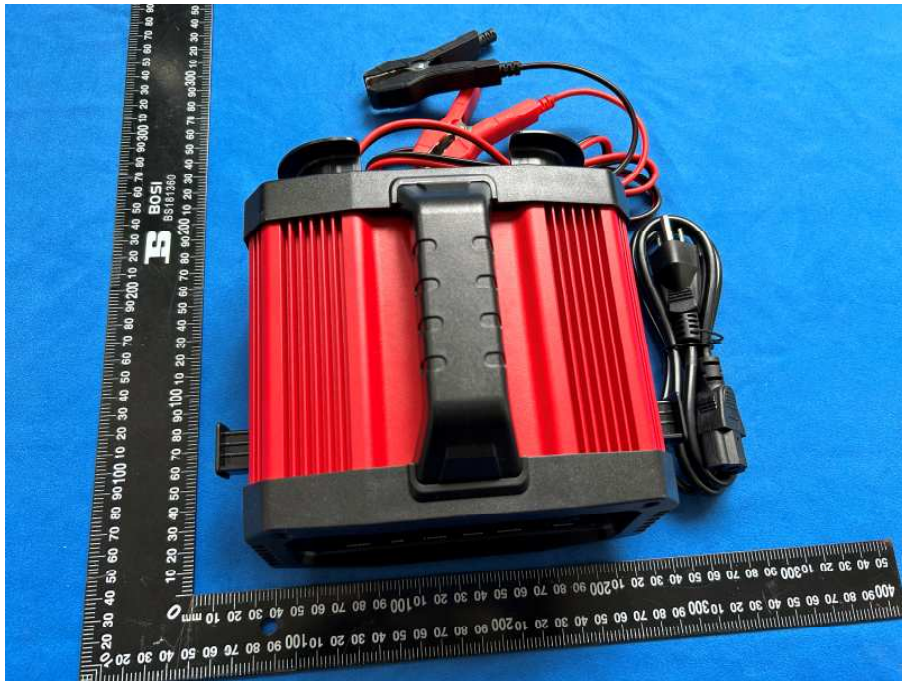

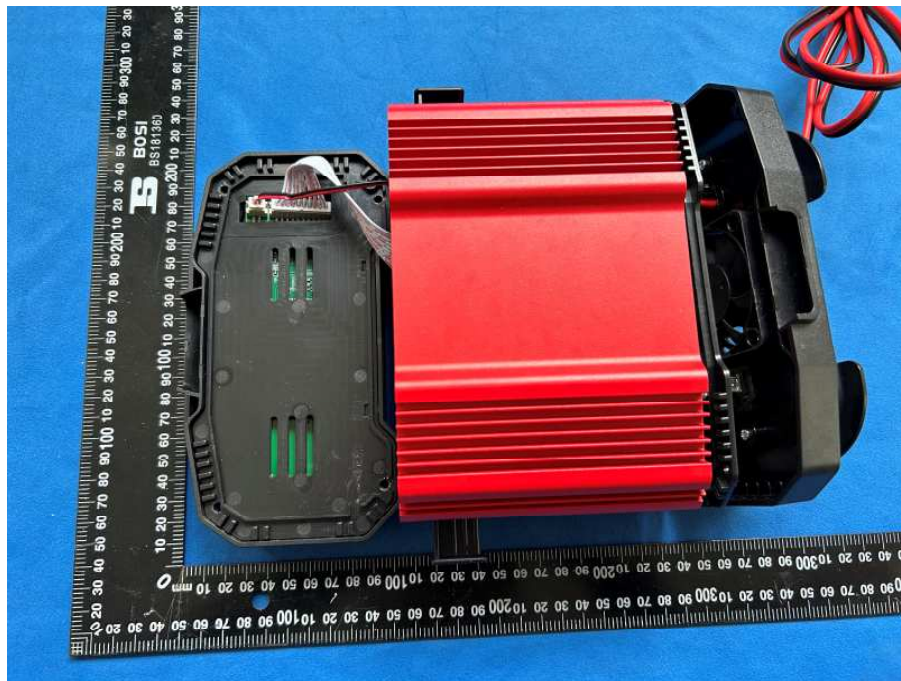

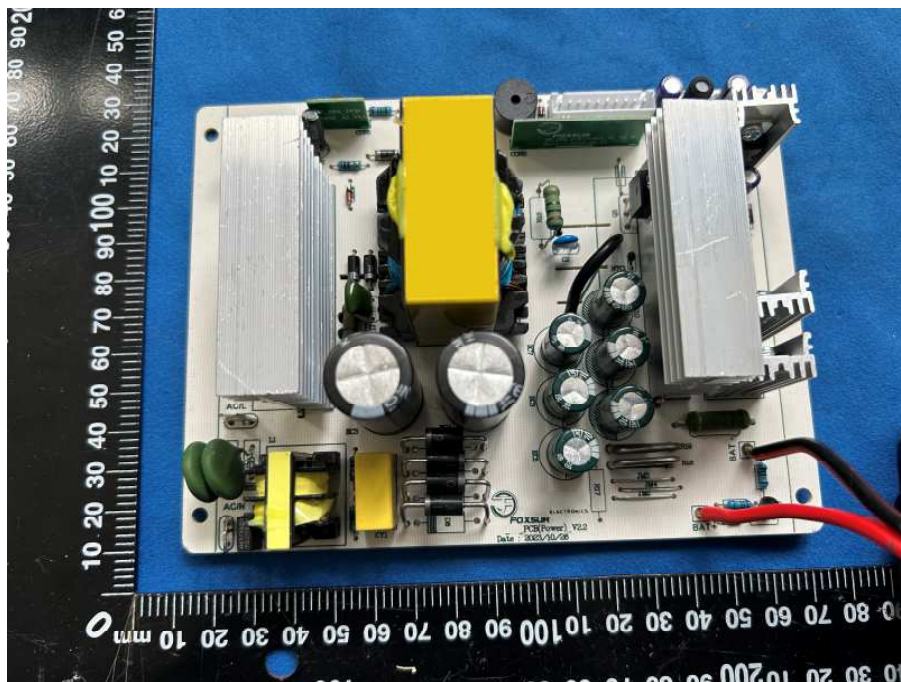

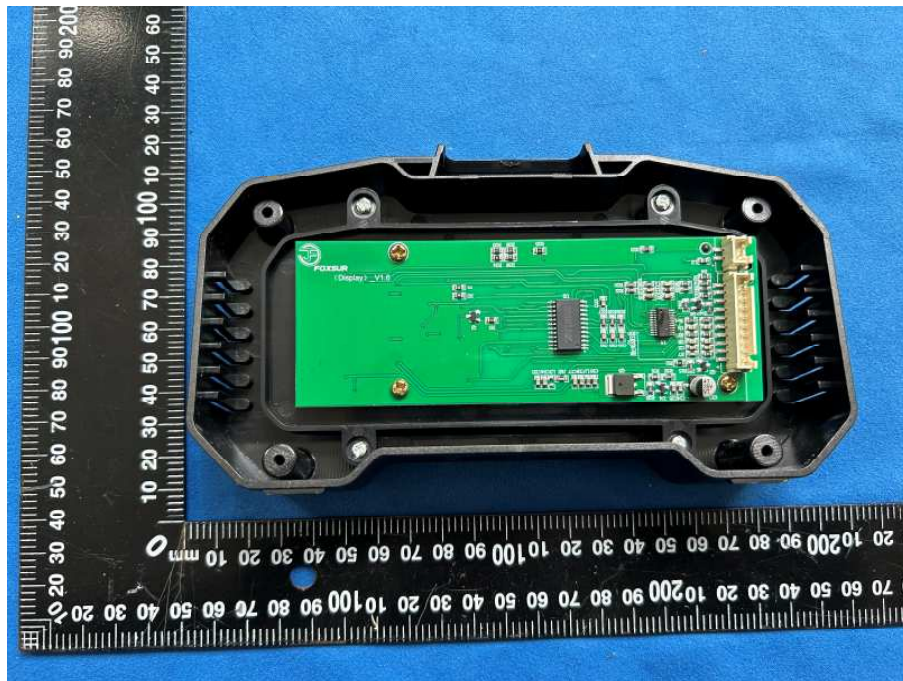
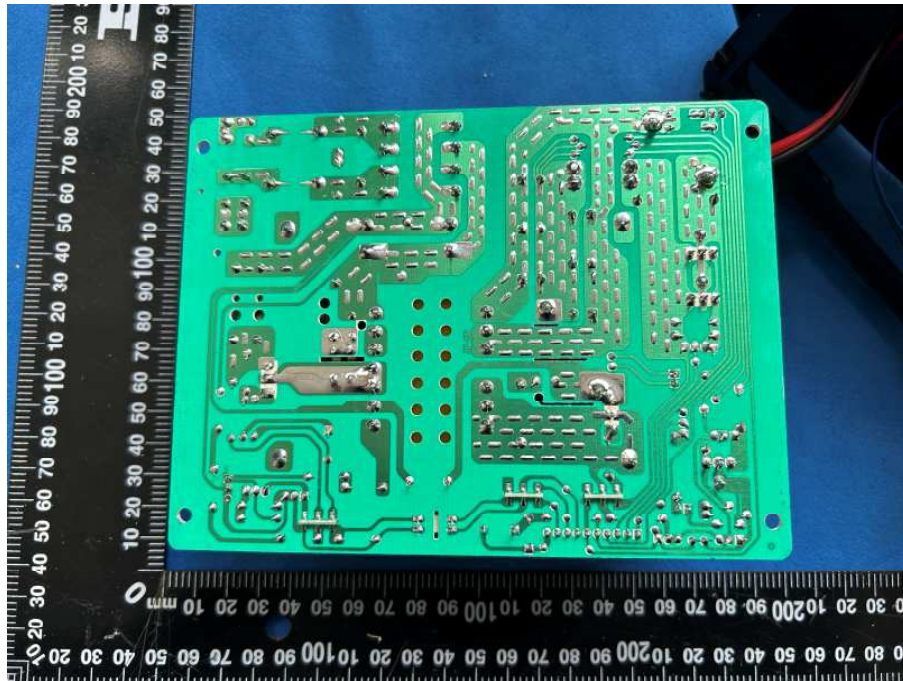

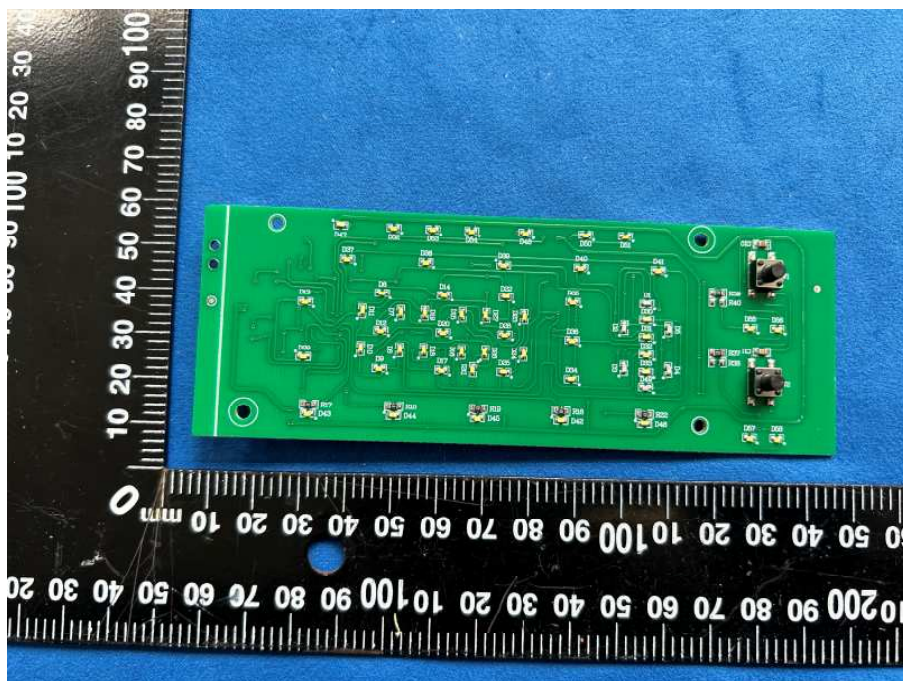
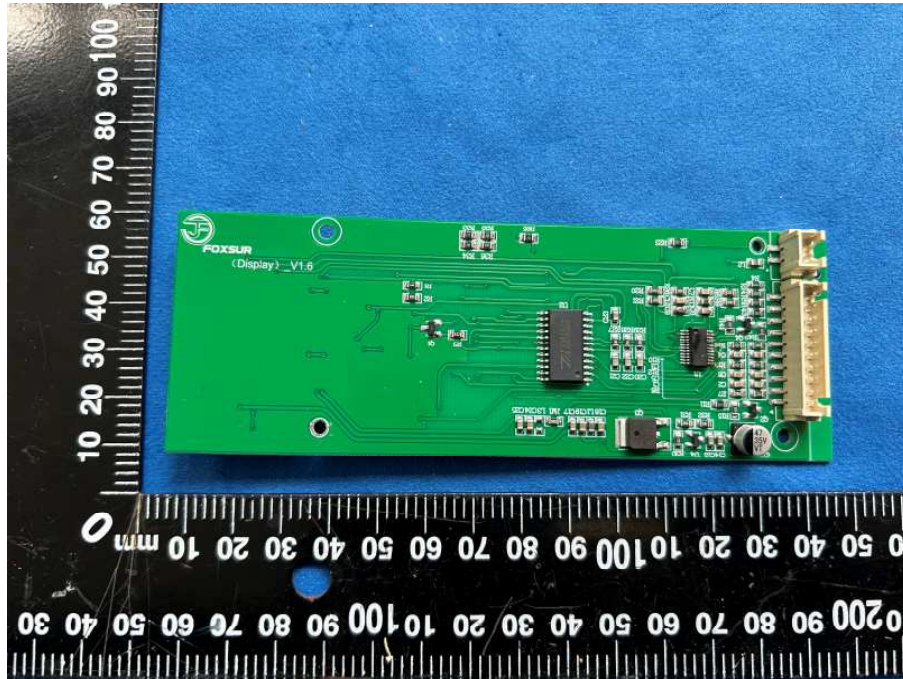

--End of the report--